

CATALOG

SafeRing/SafePlus 12-24kV

Gas-insulated ring main unit SafeRing and
Compact switchgear SafePlus



- No live parts exposed
- High reliability and safety
- Safe and easy for operators in both maintenance and operating conditions

Contents

1	Introduction	5
2	Design philosophy	9
3	Arrangement	10
4	Manufacturing	11
	4.1 Completely sealed system	11
	4.2 Factory routine tested	12
5	Safety	13
	5.1 Internal Arc Classification (IAC)	13
	5.2 Arc suppressor	17
	5.3 Interlocking and locking	18
6	SafeRing	19
	6.1 Applications SafeRing	20
	6.2 SafeRing configurations	21
7	SafePlus	24
	7.1 Applications SafePlus	25
	7.2 C - Cable switch module	26
	7.3 F - Switch-fuse module	29
	7.4 V - Vacuum circuit-breaker module	32
	7.5 V 20/V25 - High duty vacuum circuit-breaker module	35
	7.6 SI - Busbar sectionalizer module	37
	7.7 Sv - Busbar sectionalizer module	38
	7.8 Sv - Busbar sectionalizer module - Sv20/Sv25	39
	7.9 D - Direct cable connection module	40
	7.10 De - Direct cable connection module with earthing switch	41
	7.11 Be - Busbar earthing module	43
	7.12 CB - Circuit-breaker module	44
	7.13 M - Metering module	46
	7.14 Mt - Metering tariff module	48
	7.15 Side metering	49
	7.16 Mini - metering (integrated metering)	50
8	Current transformers	51
9	Measuring transformers	52
10	Combisensors	53
11	Sensors	54
12	Mechanisms	57
13	Cable bushings	60
14	Cable termination	62
	14.1 Cable termination 12 kV	64
	14.2 Cable termination 24 kV	66

15	Cable test bushings	68
16	Extension of switchgear	69
	16.1 External busbars on top	69
	16.2 Side extension	70
17	Base frame	71
18	Low voltage compartment / Top entry box	72
19	Motor operation	73
20	Transformer protection	75
21	Fuse-links	76
	21.1 Fuse selection table - CEF	78
	21.2 Fuse selection table - CEF-S	79
22	Protection relays and control products	80
	22.1 Auxilliary powered relays	81
	22.2 Self powered relays	83
	22.3 RTU and control products	85
23	Capacitive voltage indicators	87
24	Short-circuit and earth-fault indicators	89
25	Manometers/Pressure indicators	92
26	Key interlock	94
27	SafeRing / SafePlus Digital	96
	27.1 Components used in Digital-Enabled switchgears	98
	27.2 Component configuration	100
28	Marine applications	101
	28.1 Marine applications IAC AFL	102
29	Low version switchgear	103
30	Battery back-up solutions	104
31	Outdoor enclosure	106
32	Dimensions	107
33	Technical data	115
	33.1 Technical data - SafeRing	116
	33.2 Technical data - SafePlus	117
	33.3 Technical data - general	118
	33.4 Technical data - number of operations	120
34	Environmental certification	125

1 Introduction

SafeRing and SafePlus switchgear for secondary distribution were developed by ABB in Skien and introduced to the markets in 2000, replacing the previous SF₆-insulated products RGC and CTC. The installed base of SafeRing / SafePlus is more than 150 000 switchgears in more than 100 countries all over the world.

The switchgear portfolio is constantly under development to adjust to new market requirements and customers' needs. SafeRing is available in standard configurations based on a high-volume production. These standardized RMUs, which are the most required configurations within a distribution network, can be extendable upon request. SafePlus is the switchgear version of SafeRing with flexibility, modularity and higher ratings.

Customer benefits

- A wide range of functional units, easy to extend and upgrade
- Up to five modules in one common gas tank
- No live parts exposed
- Fully sealed for lifetime
- Climatically independent
- Designed and tested according to IEC
- High reliability and safety
- Compact dimensions
- Safe and easy for operators in both maintenance and operating conditions
- All operations are carried out from the front of the switchgear



Applicable standards

SafeRing / SafePlus is tested according to the following IEC-standards

- IEC 62271-1: Common specifications for high-voltage switchgear and controlgear standards
- IEC 62271-100; Part 100: Alternating current circuit-breakers
- IEC 62271-102; Part 102: Alternating current disconnectors and earthing switches
- IEC 62271-103; Part 103: Switches for rated voltages above 1 kV up to and including 52 kV
- IEC 62271-105; Part 105: Alternating current switch-fuse combinations for rated voltages above 1 kV up to and including 52 kV
- IEC 62271-200; Part 200: AC metal-enclosed switchgear and control gear for rated voltages above 1 kV and up to and including 52 kV
- IEC 60529: Degrees of protection provided by enclosures (IP code)

SafeRing / SafePlus is also tested together with Compact Secondary Substations (CSS) according to IEC 62271-202 standard. Tests have been performed on CSS from various manufacturers.

Industries

Pulp and Paper, Cement, Textiles, Chemicals, Food, Automotive, Petrochemical, Quarrying, Oil and gas pipelines, Rolling mills, Mines

Utilities and Power Plants

Power generation stations, Transformer stations and metering, Main and auxiliary switchgear, Wind turbines, Solar/PV, Hydro power plants

Transport

Airports, Ports, Railways, Underground transport

Infrastructure

Hotels, Shopping centers, Hospitals, Commercial buildings, Large infrastructure and civil works

Normal operation conditions

The rated characteristics of the switchgear are valid under the following ambient conditions:

- minimum ambient temperature $-25\text{ }^{\circ}\text{C}$
- maximum ambient temperature $+40\text{ }^{\circ}\text{C}$

For different temperature ranges, please contact your ABB sales representative.

Ambient humidity

- maximum 24 h average of relative humidity 95%
- maximum 24 h average of water vapour pressure 2.2 kPa
- maximum monthly average of relative humidity 90% RH
- maximum monthly average of water vapour pressure 1.8 kPa

The normal operational altitude is up to 1.500 m above sea level. For higher altitude applications, please contact your ABB sales representative.

The switchgear is designed for operation in a normal, non-corrosive and uncontaminated atmosphere.

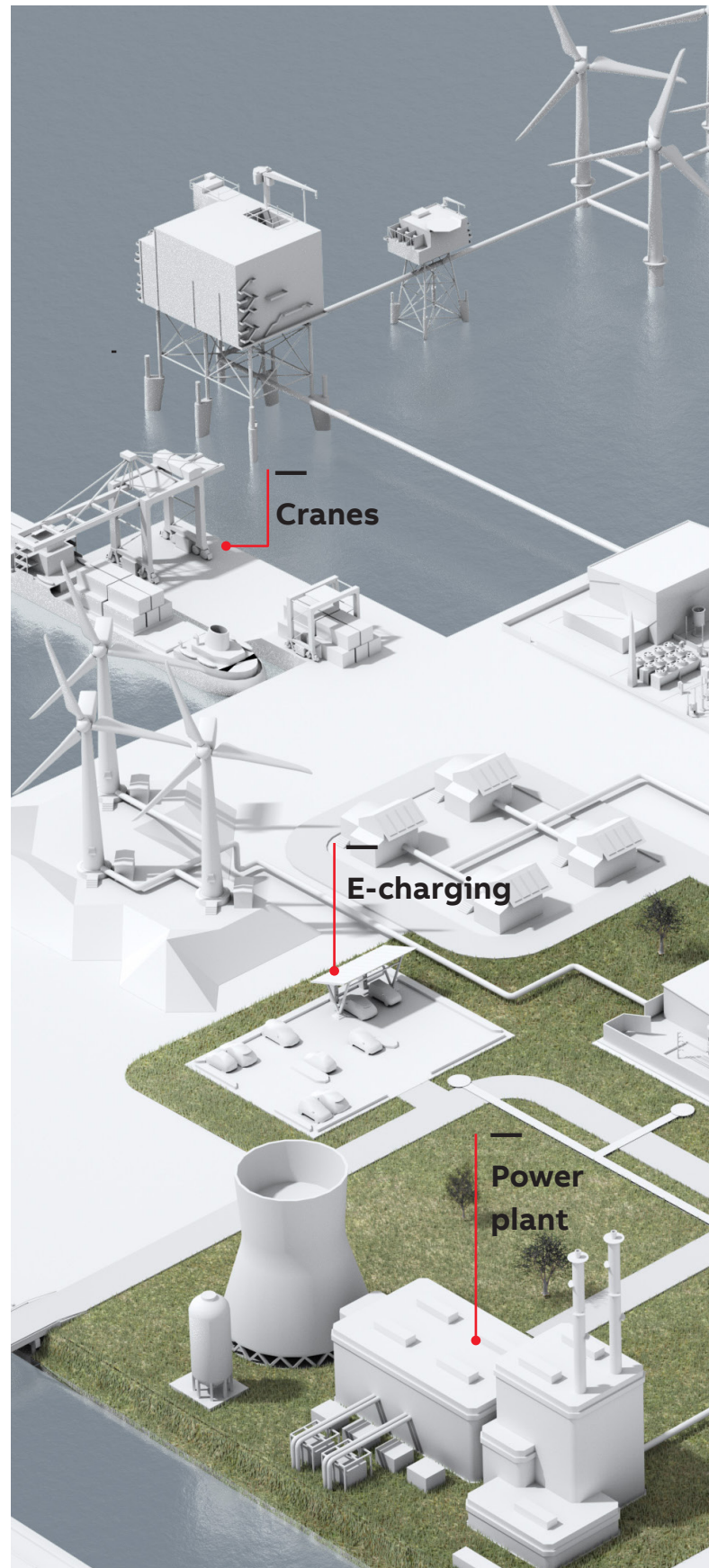

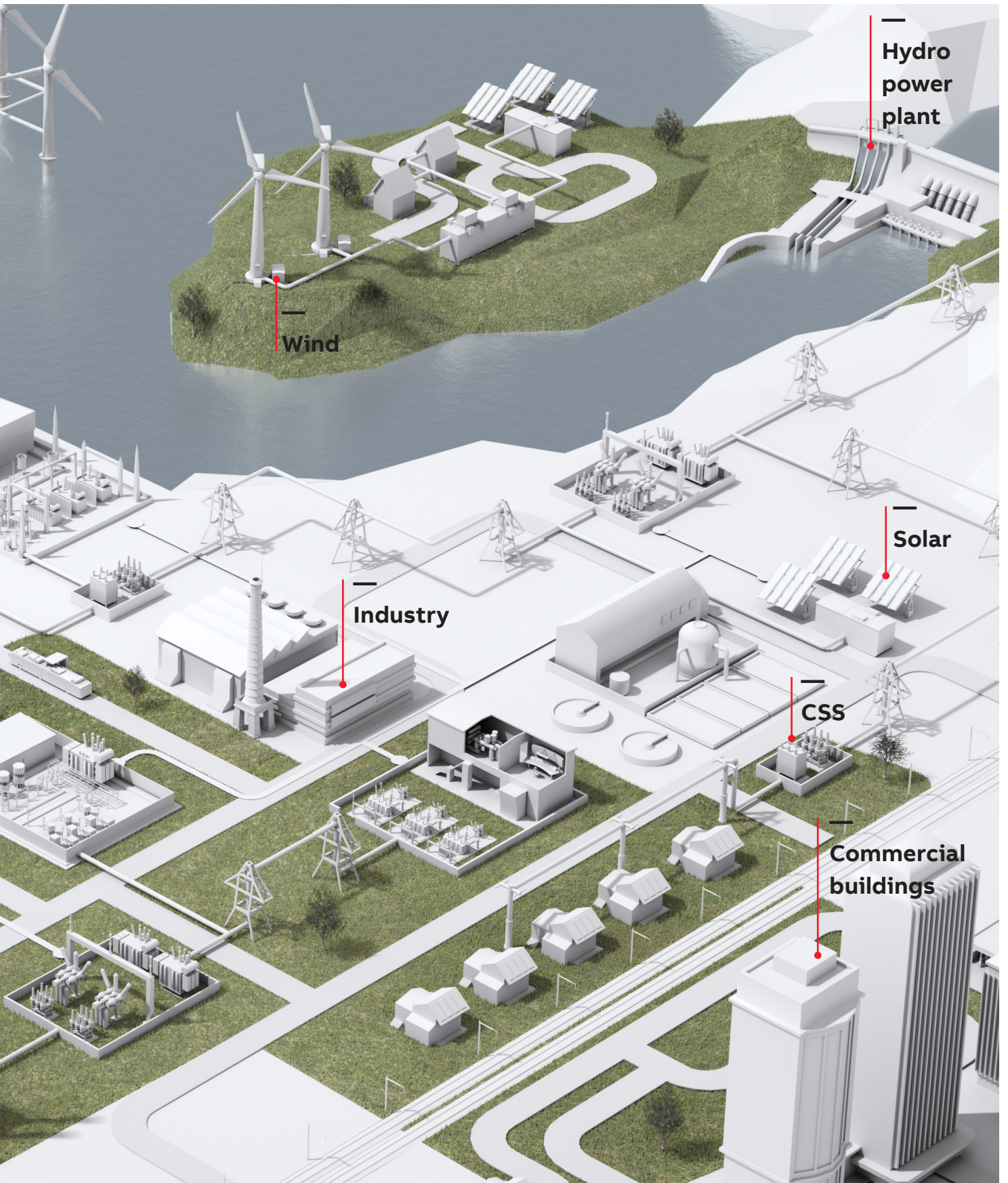

General

SafeRing is a SF₆-insulated ring main unit for the secondary distribution network. SafeRing can be supplied in 10 different configurations suitable for most switching applications in 12/24 kV distribution networks. As an option, SafeRing can be delivered as an extendable ring main unit.

SafePlus is ABB's flexible, extendable compact switchgear. Together, SafeRing and SafePlus represent a complete solution for 12/24 kV secondary distribution networks. SafeRing and SafePlus have identical user interfaces.

SafeRing / SafePlus is a completely sealed system with a stainless steel tank containing all the live parts and switching functions. A sealed steel tank with constant gas conditions ensures a high level of reliability as well as personnel safety and a virtually maintenance-free system.

Modularity and external busbars

All standard modules are only 325 mm wide. The width of non-standard modules, for example the metering module width is provided in the following pages.

SafePlus can be configured with a maximum of five modules in one SF₆ tank with an internal busbar. To configure switchgears with more than five modules as many tanks as needed can be joined together by using external busbars. Alternatively, the whole switchgear can be configured as fully modular with the use of the external busbars between all modules. The external busbar is fully insulated and screened in order to maintain climatic independence and a maintenance-free solution. All modules can be delivered prepared for future extension.

Transformer protection

SafeRing / SafePlus offers a choice between a switch-fuse combination and circuit-breaker with relay for transformer protection. The switch-fuse combination offers optimal protection against short-circuits, while the circuit-breaker with relay option offers better protection against low overcurrents. Circuit-breaker with relay is recommended for installations with larger transformers.



2 Design philosophy

SafeRing / SafePlus – ABB switchgears for secondary distribution

Secondary distribution switchgears have been the subject of significant development the past decades, resulting in increased functionality and smaller dimensions.

The traditional switching cells are substituted with complete switchgear systems. Specific functions such as grounding, disconnecting, cable connections, busbar extension, protection and switching have become integrated features in compact functional units.

Compact switchgear systems meet customers' MV application needs. ABB has always been a part of this development. The current ABB SafePlus range satisfies the most complex system specifications.

The most unique specialization is the development of the cable ring switchgear. Numerous public distribution substations requested a unified switching functionality which evolved into the ring main unit concept. The ABB SafeRing range is one major contributor to this specialization.

Two Products – One range

ABB SafeRing is adapted to the needs of the immense utility distribution network. ABB SafePlus offers more in terms of flexibility and electrical capacity. Both switchgears offer the same customer interface.

Customers' involvement

The applied functionality in ABB SafeRing and SafePlus is the result of input from customers all over the world. Key customers are continuously involved with ABB design staff to ensure optimized switchgear operation. The functionality will always find its background from customer requirements.

Personnel – safety and service

Safety is not only a specification and rating issue, but also a real life experience. Standards and associated testing will disclose weakness at the time of testing. ABB takes this further to be an objective related to durability and repetitive manufacturing quality. All products are manufactured in accordance with ISO 9001. The latest edition of relevant IEC standards will always apply to our continuous product development and test program. "Integrated functionality" is a key objective to reduce the number of moving components, further reducing the risk of any mechanical defect.

We are responsible for the environment

The location for manufacturing SafeRing and SafePlus is Norway. Norway's green policy contributes to the focus on environmental factors in manufacturing as well as over the switchgear's lifespan.

All products are manufactured in accordance with our ISO 14001 certification. Recycling is confirmed at a 97% level. To simplify this process, we will continuously work with our partners to develop routines for handling end of life. Plastic parts are individually marked to simplify the recycling process. Solutions for elimination of gas emission in the rare event of a fault can be supplied.

Modern – development and manufacturing

Numerical simulations together with long experience ensure a compact and robust design. Dielectric simulations ensure that compactness will not influence the dielectric capability.

The combination of design techniques, experience and the most modern production technology guarantees state of the art products and durability.

Complete solutions – one supplier

Complex applications involving different standard remote levels, such as monitoring, control and measurement and protection can now be supplied from one supplier.

This makes large scale implementation feasible and simplifies engineering and procurement.

The control and monitoring unit available for SafeRing is located behind the front cover. This option is also readily available for retrofit since such demands normally evolve after the switchgear is in service.

3 Arrangement

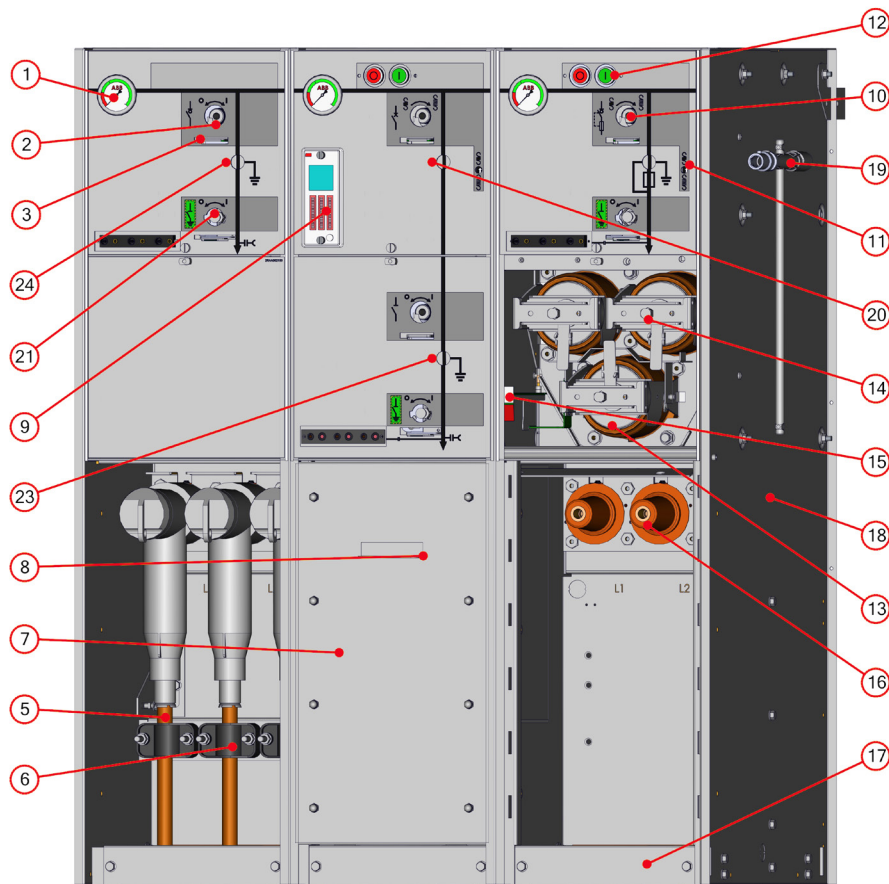

Description	
Manometer	1
Operating shaft disconnecter	2
Padlock hole	3
Cable	5
Cable clamp	6
Arc proof cable compartment	7
Door handle	8
Self powered protection relay	9
Operating shaft spring	10
Charged spring indicator	11
Push buttons	12
Fuse canister	13
Fuse operating handle	14
Fuse blown indicator	15
Cable bushings	16
Bottom cover	17
Side panel	18
Operating handle	19
Vacuum circuit-breaker position indicator	20
Operating shaft earthing switch	21
Earthing switch position indicator	23
Disconnecter/earthing switch position indicator	24

Internal

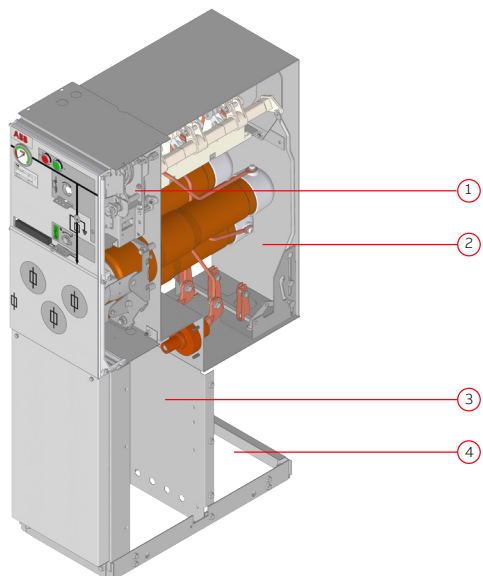

Description	ID
Mechanism compartment	1
SF ₆ gas tank	2
Cable compartment	3
Pressure relief area	4

4 Manufacturing

4.1 Completely sealed system

Exterior

Upper and lower front covers are made of 3 mm aluminium covered with a polycarbonate foil. These foils contain the mimic diagram of the main circuit integrated with the position indicators for the switching devices. Background color for these foils is light grey (RAL 7035). The upper front cover is removable. The lower front cover can be opened.

There are four different cable compartment covers: standard, with inspection window, arc proof and with extra depth for parallel cables. These covers are manufactured from 1.5 mm aluzink (except the arc proof cover) and are powder coated with color RAL 7035.

All cable compartment covers are removable. Each module has a separate cable compartment which is divided from the others by means of partition walls. These partition walls can easily be removed, allowing comfortable access for connection of cables.

A vertical partition wall is fitted to divide the cable compartment(s) from the rear side of the switchgear/ring main unit.

In case of an arc fault inside the SF₆ gas tank, followed by an opening of the pressure relief valve in the bottom of the tank, this partition wall will prevent the hot gases blowing out from the pressure relief to enter the cable compartments. Side covers are made of 2 millimeter hot rolled steel and powder coated with color RAL 7035.

SafeRing and SafePlus use SF₆ gas (sulphur hexafluoride) as insulation and arc quenching medium. The SF₆ gas is contained in a welded stainless steel tank, which is sealed for life.

The pressure system is defined as a sealed for life system with an operating lifetime exceeding 30 years. The leakage rate is less than 0.1% per year.

In order to ensure a reliable and tight welding, all welding work is carried out by computer controlled robots. Electrical and mechanical bushings penetrating the tank are clamped and sealed to the tank by high quality O-rings.

The mechanical bushing has an additional rotating shaft which connects the shaft of the switch to the corresponding shaft of the mechanism. The rotating shaft is sealed by a double set of gas seals.

All SF₆ gas tanks have to pass a leakage test before gas filling. Leakage test and gas filling are done inside a vacuum chamber. The first step in the leakage test is to evacuate all air inside both the gas tank and vacuum chamber simultaneously. Then the gas tank is filled with helium. Due to the characteristics of helium this test will detect all possible leakages. If the gas tank passes this test the helium will be evacuated and replaced by SF₆.

The SF₆ gas tank has a degree of protection of IP67 and can be immersed into water and still maintain all functions in a satisfactory way.

Enclosure

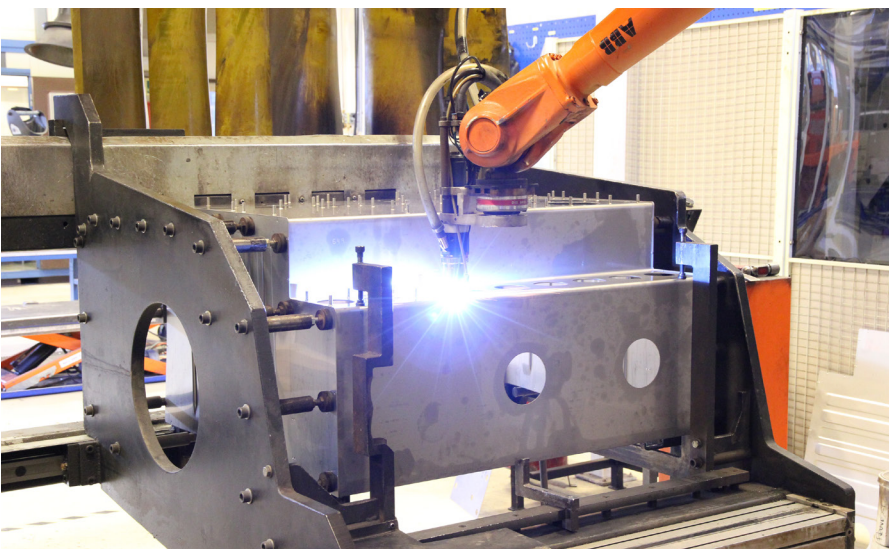

4.2 Factory routine tested

ABB has set a high quality automated system for production and quality control which assures sustainability of factory output. Part of the assurance is standard routine testing procedures according to IEC62271-200 performed on every manufactured switchgear.

IEC factory routine tests:

- Visual inspection and check
- Mechanical operations check
- Check of secondary wiring
- Electrical sequence operations
- Power frequency withstand voltage test
- Partial discharge measurement
- Measurement of resistance of the main circuits
- Secondary insulation test
- Control of the gas tightness

State of the art

For the routine testing, ABB uses the latest technologies and systems, such as:

- Fully automated high-voltage testing cabin
- Temperature compensated gas filling system
- Automated connection counting system
- Automated screw torque control
- Computer aided mechanical characteristics control

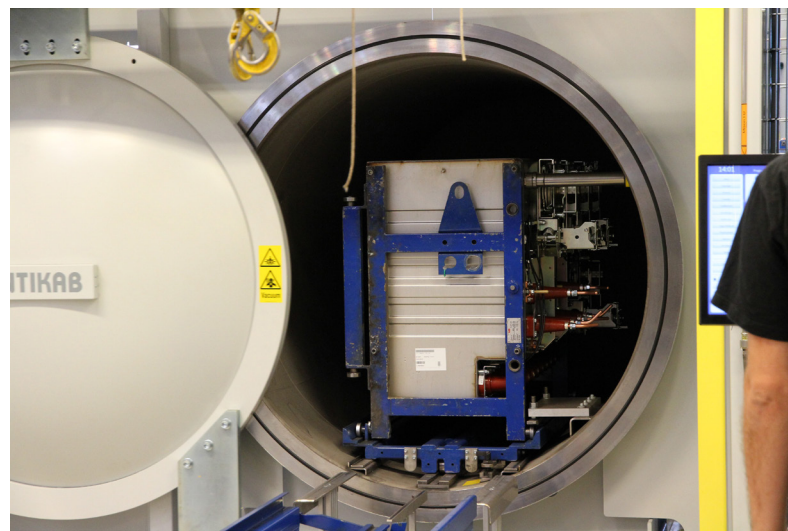

5 Safety

5.1 Internal Arc Classification (IAC)

01 Arc duration and damage caused

During development of all ABB products, focus is on personnel safety. The SafeRing / SafePlus portfolio is designed and tested to withstand a variety of internal arc scenarios at the same current level as the maximum short-circuit current. The tests show that the metal enclosure of SafeRing / SafePlus is able to protect personnel standing close to the switchgear during internal arc fault.

Causes and effects of internal arcs

Although an internal arc fault is highly unlikely it can theoretically be caused by various factors, such as:

- Insulation defects due to quality deterioration of the components. The reasons can be adverse environmental conditions and a highly polluted atmosphere
- Inadequate training of the personnel in charge of the installation leading to incorrect installation of the cables
- Broken or modified safety interlocks
- Overheating of the contact area, e.g. when the connections are not sufficiently tightened
- Short circuits caused by small animals that have entered into the cable compartment (i.e. through cable entrance)

The energy produced by the internal arc causes the following phenomena:

- Increase of the internal pressure
- Increase of the temperature
- Visual and acoustic effects
- Mechanical stresses on the switchgear structure
- Melting, decomposition and evaporation of materials

Tested according to IEC standard 62271-200

The capability of SafeRing / SafePlus switchgear to withstand internal arc is proven by type tests performed according to internal arc classification (IAC) as described in the standard IEC 62271-200 as follows. Accessibility A and B (switchgear)

A = Accessible to authorized personnel only
300 mm safety distance on accessible sides of the switchgear (also distance to sensors during testing)

B = Public access
100 mm safety distance on accessible sides of the switchgear (also distance to sensors during testing)

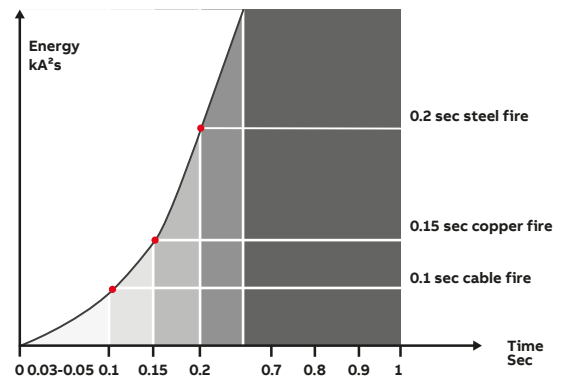

01

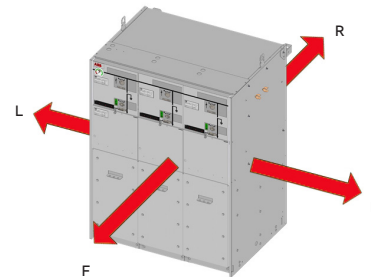

F (front) = Access from the front
L (lateral) = Access from sides
R (rear) = Access from the rear

Accessible sides of switchgear = Area that personnel can enter freely. For accessibility A this means a 300 mm safety distance + 500 mm or more in safe moving area.

Non-accessible side of switchgear = Area that is physically blocked or clearly marked as not safe for personnel.

All test specimens passed the following test criteria according to the standards:

1. Correctly secured doors and covers do not open
2. No fragmentation of the enclosure occurs within the time specified for the test. Projection of small parts up to an individual mass of 60 g are accepted
3. Arcing does not cause holes in the enclosure of the switchgear up to a height of 2 m
4. Indicators do not ignite due to the effect of hot gases
5. The enclosure remains connected to its earthing point

5.1 Internal Arc Classification (IAC)

—
01 *290 mm base frame available as an option. Note: The height of the exhaust channel must always be 2002 mm in order to comply with the requirements in IEC standards. When the base frame is 290 mm, the exhaust channel is extended to reach 2002 mm height

—
02 1100 mm version available as an option

SafeRing / SafePlus is available for a wide range of installations and applications in order to secure the highest safety for operators.

Switchgears are designed and type-tested for internal arc classification according to the following configurations:

5.1.1 IAC AFLR - with ventilation upwards through an exhaust channel

With this setup, hot gasses and pressure are evacuated into the safe area of the switchgear room above the switchgear through the gas exhaust channel. In this setup the switchgear can be installed as free standing. This solution is not available for M-module. With this solution, a base frame of 450 mm (optional 290 mm) is included as standard.

Basic parameters of setup:

- IAC AFLR up to 25 kA / 1s
- Minimum height of ceiling: 2600 mm
- Minimum distance from backwall:
 - 800 mm with accessible rear side
 - 100 mm with non-accessible rear side
- Switchgear needs to be installed and fixed to the floor in accordance with "SafeRing / SafePlus 12-24kV Installation and operating instructions"

For number of modules, availability, heights and specifications, see table no. 5.1.1.

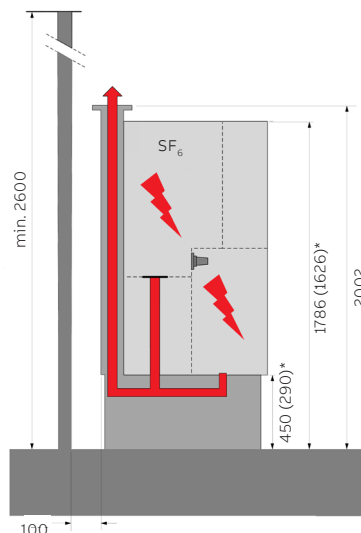

—
01

5.1.2 IAC AFLR or AFL - downwards ventilation with ventilation down to the cable trench.

With this setup, hot gases and pressure are evacuated downwards in the cavity in the floor beneath the switchgear. Hot gases are led to the cable trench by means of a back plate installed on the rear side of the switchgear, forcing the hot gases down during an arc fault. The switchgear must be arranged as instructed according to the basic parameters below.

Basic parameters of set-up:

- IAC AFLR or AFL up to 20 kA / 1s
- Minimum height of ceiling: 2000 mm
- Recommended distance to back wall:
 - 800 mm with accessible rear side
 - 100 mm recommended for non-accessible rear side (possible down to 20mm)
- Back plate installed on the switchgear
- Requires a minimum opening between switchgear and cable trench in the "pressure relief area" for each module shown as opening "A" in illustration "02".
 - Opening "A" in a 1-way module: 250x205mm
 - Opening "A" in 2-5 way modules: 150x205mm
 It is optional to cover opening "B" between the switchgear cable compartment and the cable trench with a gland plate. This is not an allowed option for low version switchgears.
- Minimum width of cable trench: 475 mm
- Minimum depth of cable trench: 450 mm
- A pressure relief channel to a safe area is required and it must have a free opening area of 0.1m²
- Switchgear needs to be installed and fixed to the floor in accordance with "SafeRing / SafePlus 12-24kV Installation and operating instructions".

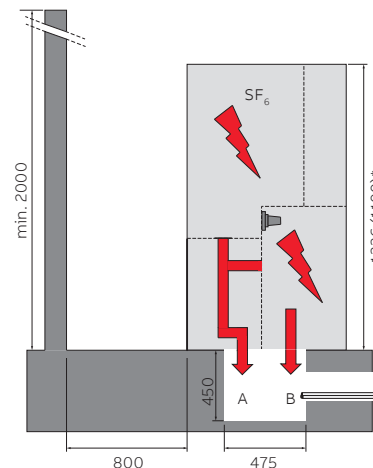

—
02

—
01 If the distance from the side wall is greater than 20 mm, arc shields on both sides are required. Marked area is restricted, but installation is allowed if mounting of arc shield is feasible.

—
02 Arc shield He of arc shield for M-module is 1317 mm.

—
03 Arc shield with base frame.

—
04 1100 mm version available as option.

5.1.3 IAC AFL – Backwards ventilation with ventilation behind the switchgear.

With this setup, hot gases and pressure are evacuated behind the switchgear. Hot gases are led to the safe areas of the switchgear room by means of arc shields installed on accessible lateral sides of the switchgear or as a combined solution with additional ventilation down into a cable trench.

Basic parameters of set-up:

- IAC AFL up to 20 kA / 1s
- Minimum height of ceiling: 2400 mm
- Arc shields need to be installed if the distance between the switchgear and respective sidewall(s) is more than 20 mm to maintain its AFL
- Arc shields are 100 mm
- Minimum distance to back wall: 100 mm

- Larger distances can be accepted if the area between the switchgear and back wall is non-accessible.
- Switchgear needs to be installed and fixed to the floor in accordance with “SafeRing / SafePlus 12-24kV Installation and operating instructions”

For number of modules, availability, heights and specifications, see table no. 5.1.1.

5.2.4 Non-arc proof version

The non-arc proof version of the switchgear is not verified for any of the IAC-classes. In the highly unlikely event of an internal arc fault in the switchgear, hot gases and pressure could evacuate randomly in any direction at any place of enclosure.

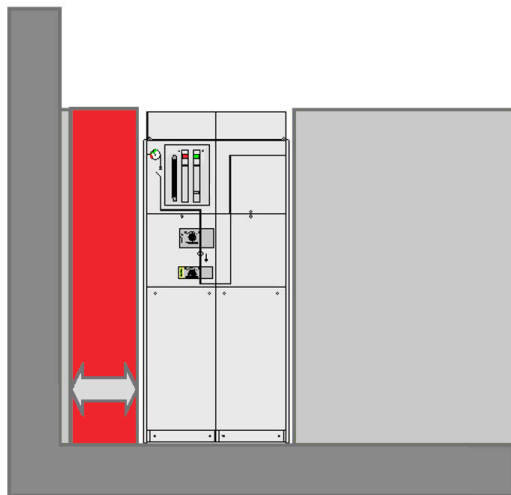

—
01

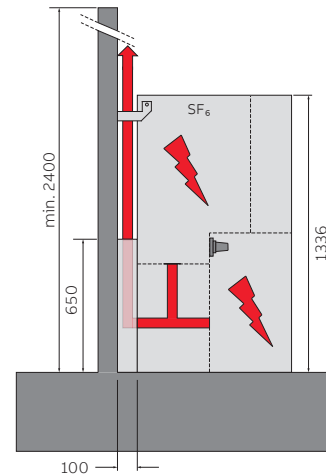

—
02

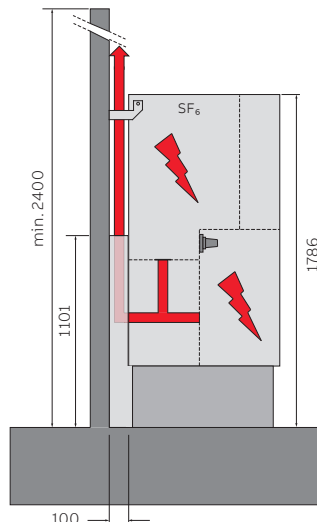

—
03

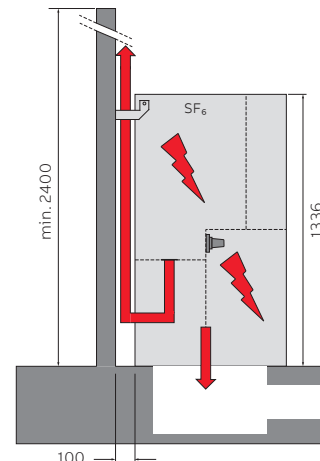

—
04

Table 5.1.1

ISC (kA/1s)	IAC class	Ventilation	Height of switchgear (mm)	Roof height (mm)	Base frame	Max sets of current transformers
16	AFL	Backwards	1336 (standard) 1100 (low)	2400 (standard) 2400 (low)	Optional (290/450 mm)	2 ²⁾
	AFL	Downwards ³⁾	1336 (standard) 1100 (low) ⁶⁾	2000 (standard) 2000 (low)	Optional (290/450 mm)	2 ²⁾
	AFLR	Downwards ³⁾	1336 (standard) 1100 (low) ⁶⁾	2000 (standard) 2000 (low)	Optional (290/450 mm)	2 ²⁾
	AFLR	Upwards ⁴⁾	2002 ¹⁾	2600	Mandatory ⁵⁾ (290/450 mm)	2 ²⁾
20	AFL	Backwards	1336 (standard) 1100 (low)	2400 (standard) 2400 (low)	Optional (290/450 mm)	2 ²⁾
	AFL	Downwards ³⁾	1336 (standard) 1100 (low) ⁶⁾	2000 (standard) 2000 (low)	Optional (290/450 mm)	2 ²⁾
	AFLR	Downwards ³⁾	1336 (standard) 1100 (low) ⁶⁾	2000 (standard) 2000 (low)	Optional (290/450 mm)	2 ²⁾
	AFLR	Upwards ⁴⁾	2002 ¹⁾	2600	Mandatory ⁵⁾ (290/450 mm)	2 ²⁾
25	AFLR	Upwards ⁴⁾	2002 ¹⁾	2600	Mandatory ⁵⁾ (450 mm)	2 ²⁾

1) Height of exhaust channel is always 2002 mm. This dimension is independent of the height of the base frame and switchgear.

2) In case two sets of CT's are required, additional base frame is mandatory and gland plate is not allowed as second set of CT's will be installed in base frame.

3) IAC classification is unavailable in case of installation deviating from basic parameter set-up described in "downwards ventilation" section on previous pages.

4) Upwards ventilation solution requires a base frame for attaching the gas exhaust channel. Only available from 2-way to 5-way switchgears.

5) Not allowed with gland plate between switchgear and base frame, gland plate can be installed below base frame.

6) Not allowed with gland plate on low version for this ventilation direction

5.2 Arc suppressor

—
01 Arc suppressor
inside the tank

Arc suppressor – active device for increased safety

The arc suppressor is an optimal quick-make short circuit device with a mechanical pressure detector which can be installed in each incoming feeder inside the sealed SF₆ gas tank of SafeRing and SafePlus switchgear.

If an arc fault should occur inside the SF₆ gas tank the pressure device of the arc suppressor will automatically trip and short circuit the incoming feeder(s) within milliseconds, thereby extinguishing the arc and preventing a gas blowout. The arc is extinguished without any emission of hot gases and the bolted short circuit will be interrupted by the upstream circuit-breaker.

No links or release mechanisms are installed outside the tank. Corrosion and any environmental influences are therefore prevented, giving optimum reliability.

The pressure detector is insensitive to pressure changes due to variation in atmospheric temperature or pressure, as well as external phenomena such as vibrations or shocks.

The arc suppressor is tested for short-circuit currents in the range of 1kArms to 21kArms and it will reduce the generated arc energy to less than 5% of the arc energy released during an arcing time of 1 second.

Since the system is self-contained, an internal arc fault in the tank will have no impact on the surroundings, so there will be no cleaning work required. No arc fault tests have to be repeated in combination with channel release systems or transformer stations.

Arc protection in IED (Intelligent Electronic Device)

Protection relays REF615 and REF620 IED can optionally be fitted with a fast and selective arc flash protection. It offers a two- or three-channel arc-fault protection system for arc flash supervision of different cable compartments of switchgear modules. Total tripping time is less than 100 ms.

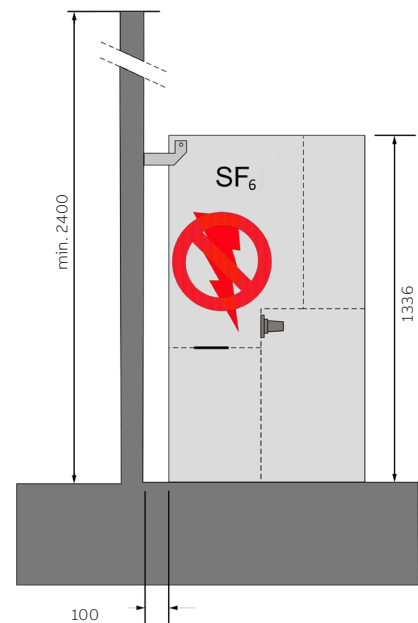
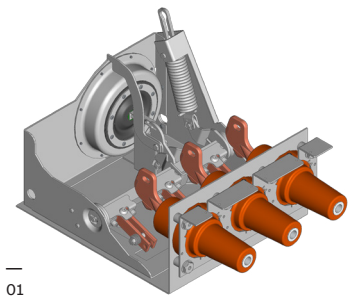

5.3 Interlocking and locking

Interlocks

The safety mechanical interlocks between switches are standard and detailed information is described for each module. They are set out by the IEC standards and are necessary to guarantee the correct operation sequence.

ABB safety interlocks enable the highest level of reliability, even in the case of an accidental error, and ensure operator safety.

Keys

The use of key interlocks is very important in realizing the interlocking logic between panels of the same switchgear or of other medium, low and high voltage switchgear. The logic is realized by means of distributors or by ringing the keys. The earthing switch closing and opening operations can be locked by means of keys. For a more detailed description, see dedicated interlocking pages for each module and chapter 26 "Key interlocks".

Padlocks

The cable compartment doors can be locked in the closed position by means of padlocks. The padlock can also be applied to the switches to avoid improper operation of the switchgear.

For a more detailed description, see dedicated interlocking pages for each module. Padlocks from 4 to 8 mm diameter can be accommodated.

Blocking coil/electrical interlocking

The earthing switch closing/opening operations can be electrically interlocked by use of electrical blocking coils. Voltage presence system with signalling contact is required. For a more detailed description, see dedicated interlocking pages for each module.

Undervoltage release

This release opens the circuit-breaker when there is a sharp reduction or cut in the power supply voltage. This is an optional feature.

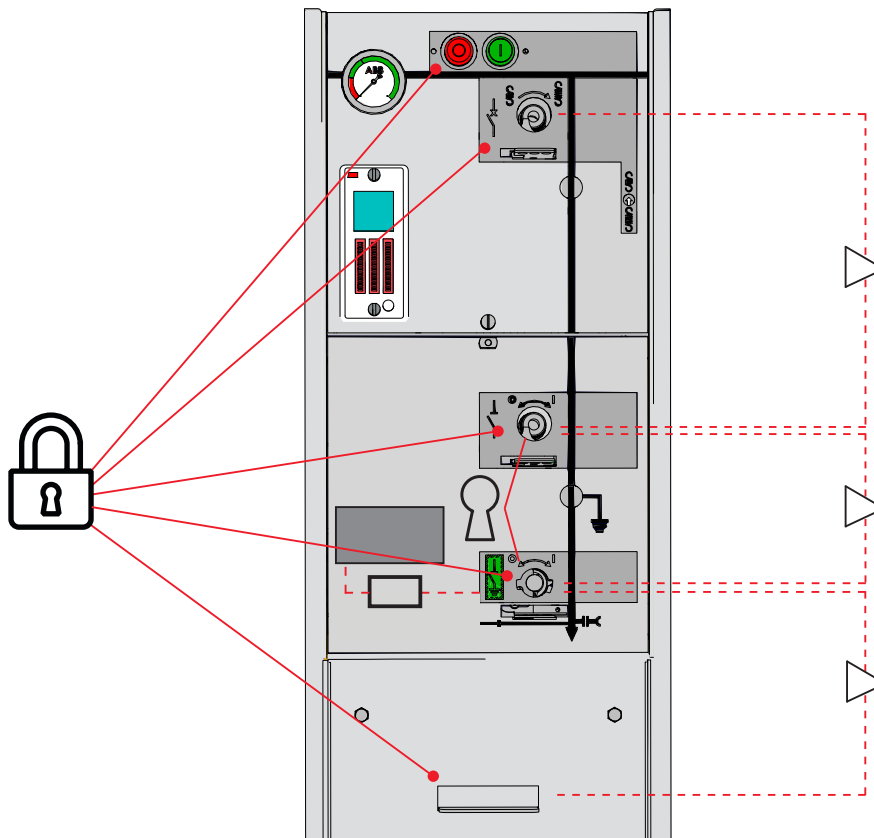

6 SafeRing

SafeRing installed in Compact Secondary Substations

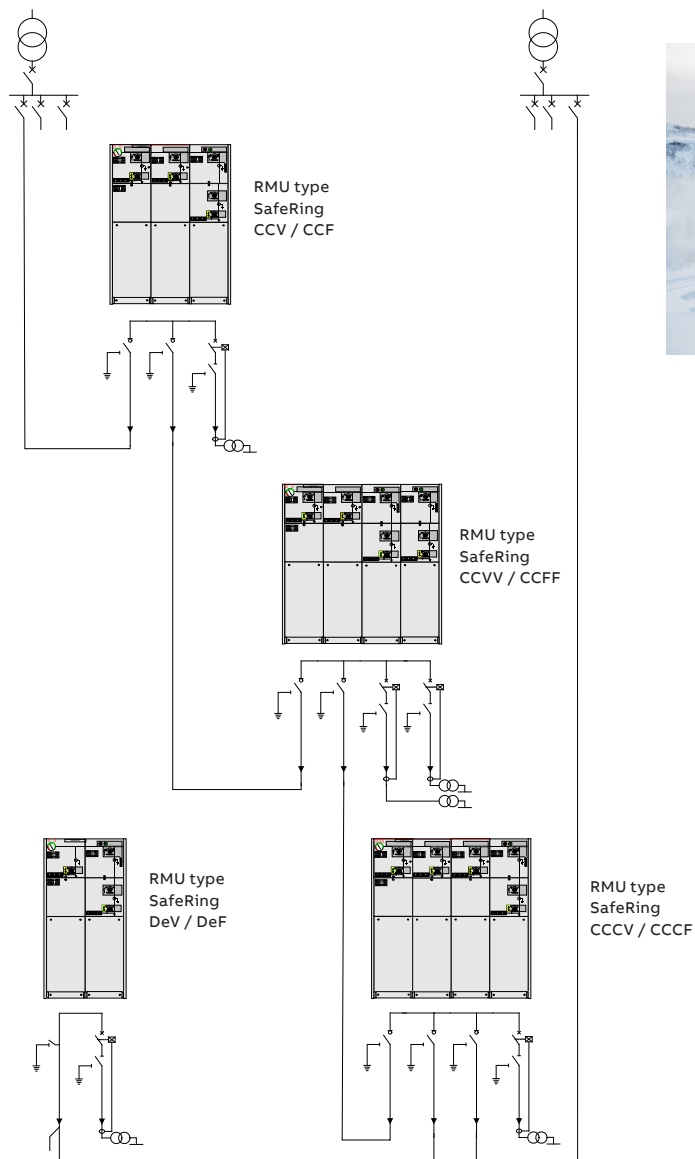

6.1 Applications SafeRing

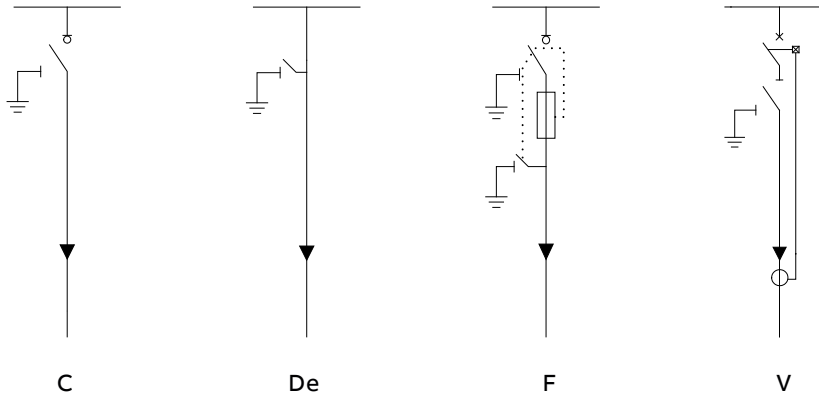

SafeRing is designed for use in the following applications:

- Compact secondary substations
- Small industries
- Wind power plants
- Solar/PV plants
- Hotels, shopping centers, office buildings, business centers etc.
- Light mining applications, airports, hospitals, tunnels and underground railways

Available modules:

- C Cable switch
- De Direct cable connection with earthing switch
- F Switch-fuse disconnecter
- V Vacuum circuit-breaker

6.2 SafeRing configurations

General

SafeRing is a ring main unit for the secondary distribution network. SafeRing can be supplied in 10 different configurations suitable for most switching applications in 12/24 kV distribution networks. As an option, SafeRing can be delivered as an extendable ring main unit.

SafeRing is supplied with the following standard equipment

- Earthing switches
- Operating mechanisms with integrated mechanical interlocking
- Operating handle
- Facilities for padlocks on all switching functions
- Bushings for cable connection in front with cable covers
- Lifting lugs for easy handling
- All 3- and 4-way units are designed for the subsequent fitting of an integrated remote control and monitoring unit
- Cable compartment cover allowing surge arrester or double cable connection
- Busbar, 630A
- Earthing bar
- Capacitive voltage indication

Optional features

- Bushings for connection of external busbar on top of the ring main unit
- Bushings (inner cone type) for side connection (400A) (C-, F- and De-modules only)
- Bushings for cable testing, including earthing device (C- and De- modules only)
- Interlocking of compartment for cable test bushings
- Arc suppressor with signal (1NO) wired to terminals (only on incoming feeders)

- Arc proof and interlocked cable covers
- Signal (1NO) from internal pressure indicator wired to terminals (only one each SF₆ gas tank)
- Latched single spring mechanism for ring cable switch
- Interlock cable compartment
- Extra base frame (h=450 mm or 290 mm)

Optional features also available as retrofit

- Manometer for SF₆ pressure monitoring (temperature compensated)
- Integrated control and monitoring unit (ICMU)
- Integrated battery and charger
- Motor operation
- Trip coil open
- Trip coil open and close
- Auxiliary switch for load break switch position 2NO+2NC
- Aux. switch for vacuum circuit-breaker position 2NO+2NC
- Aux. switch for disconnecter position 2NO+2NC
- Aux. switch for earth switch position 2NO+2NC
- Aux. switch for fuse blown 1NO
- Vacuum circuit-breaker tripped signal 1NO
- Top entry box
- Relays and RTU (Remote Terminal Unit)
- Different key interlocking systems
- External current and voltage sensors for monitoring
- Fault passage indicators
- Cable compartment cover with inspection window
- Arc proof cable cover with inspection window
- Deep cable cover for double connection
- Cable support bars, non-magnetic and adjustable
- Earthing bar for surge arrester



CCV



CCF

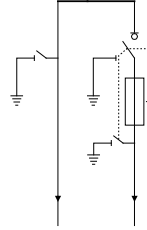
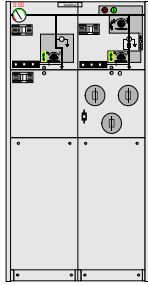

DeF

Depth: 751mm
 Width: 696 mm
 Height: 1336/1100* mm

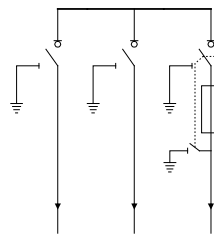
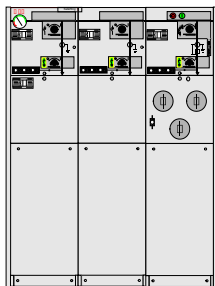

CCF

Depth: 751 mm
 Width: 1020 mm
 Height: 1336/1100* mm

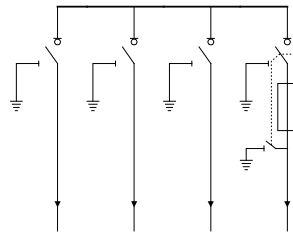
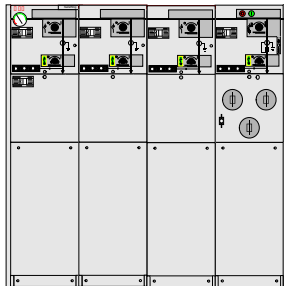

CCCF

Depth: 751 mm
 Width: 1346 mm
 Height: 1336/1100* mm

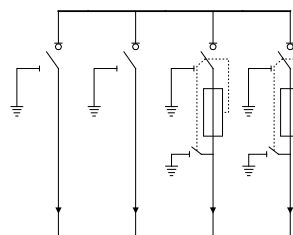
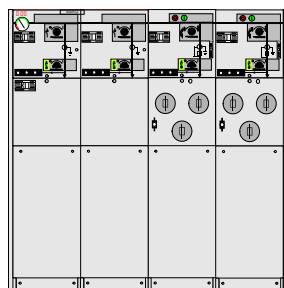

CCFF

Depth: 751 mm
 Width: 1346 mm
 Height: 1336/1100* mm

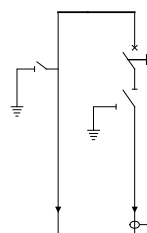
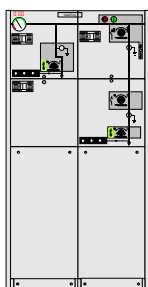

DeV

Depth: 751 mm
 Width: 696 mm
 Height: 1336/1100* mm

* 1100 mm version as optional solution

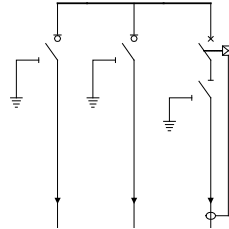
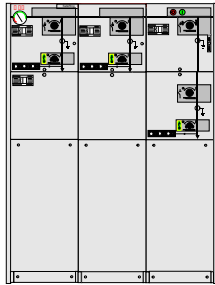

CCV

Depth: 751 mm
 Width: 1020 mm
 Height: 1336/1100* mm

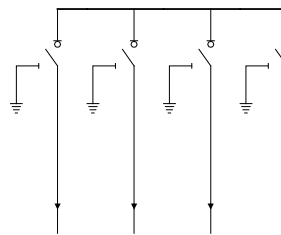
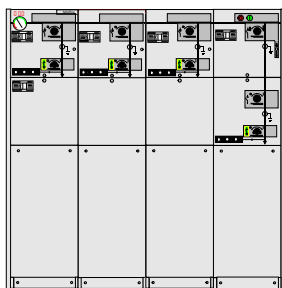

CCCV

Depth: 751mm
 Width: 1346 mm
 Height: 1336/1100* mm

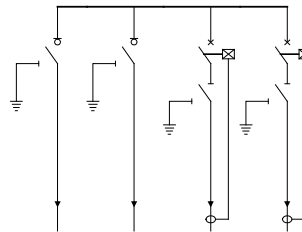
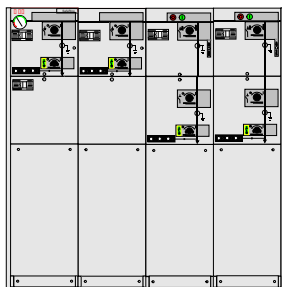

CCVV

Depth: 751 mm
 Width: 1346 mm
 Height: 1336/1100* mm

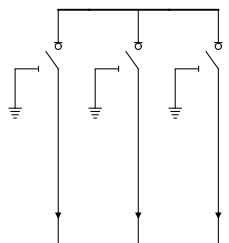
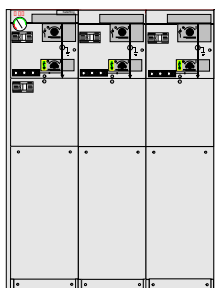

CCC

Depth: 751 mm
 Width: 1020 mm
 Height: 1336/1100* mm

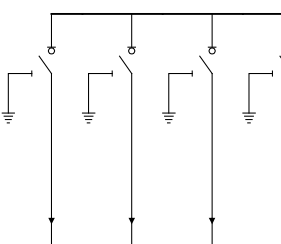
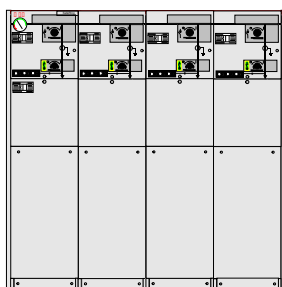

CCCC

Depth: 751 mm
 Width: 1346 mm
 Height: 1336/1100* mm

* 1100 mm version as optional solution

7 SafePlus

General

SafePlus is a metal enclosed compact switchgear system for up to 24 kV distribution applications. The switchgear has a unique flexibility due to its extendability and the possible combination of fully modular and semi-modular configurations.

SafePlus combined with SafeRing, which is ABB's standard ring main unit, represent a complete solution for 12/24 kV distribution networks.

SafePlus and SafeRing have identical user interfaces, operation procedures, spare parts and components.

SafePlus is a completely sealed system with a stainless steel tank containing all live parts and switching functions.

A sealed steel tank with constant gas conditions ensures a high level of reliability as well as personnel safety and a virtually maintenance-free system. As an option, external busbars can be provided to obtain full modularity.

The external busbar kit has to be mounted to the switchgears on site. It is fully insulated and screened to ensure reliability and climatic independence.

The SafePlus system offers a choice of either a switch-fuse combination or a circuit-breaker with relay for protection of the transformer. SafePlus accommodates a wide selection of protection relays for most applications. SafePlus can also be supplied with remote control and monitoring equipment.



7.1 Applications SafePlus

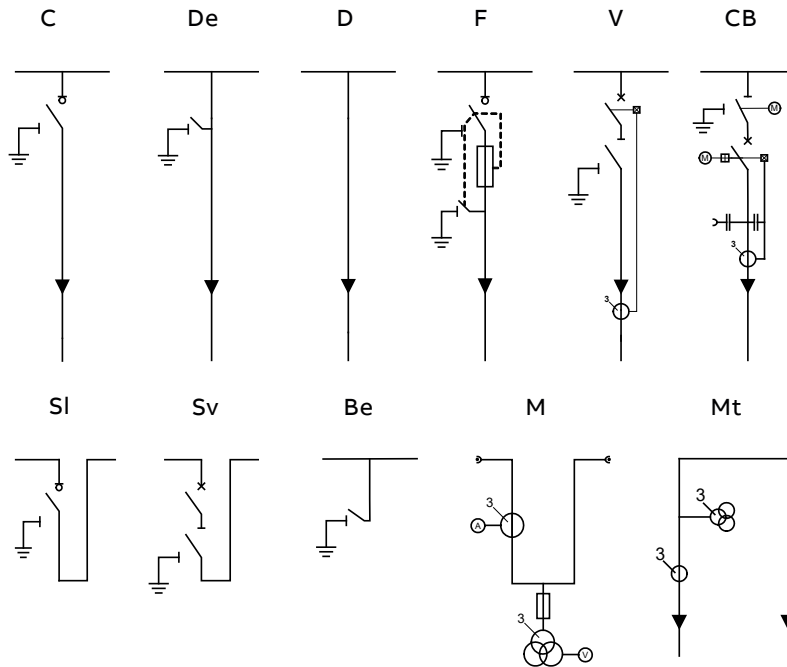

SafePlus is designed for use in the following applications:

- Compact secondary substations
- Small industries
- Wind power plants
- Solar/PV plants
- Hotels, shopping centers, office buildings, business centers etc.
- Light mining applications, airports, hospitals, tunnels and underground railways

Available modules:

C	Cable switch module
De	Direct cable connection with earthing module
D	Direct cable connection module
F	Switch-fuse disconnecter module
V	Vacuum circuit-breaker module
V20/V25	High duty vacuum circuit-breaker module 20/25kA
Be	Busbar earthing module
SI	Busbar sectionalizer, load break switch module
Sv	Busbar sectionalizer, vacuum circuit-breaker module
Sv20/Sv25	Busbar sectionalizer, vacuum circuit-breaker module 20/25kA
CB	Circuit-breaker module
M	Metering module
Mt	Metering tariff module

7.2 C - Cable switch module

The cable switch (C-module) is a three position switch-disconnector and earthing switch using SF₆ gas as an arc quenching medium. The switch positions are closed – opened – earthed. In the open position the switch satisfies the disconnector requirements.

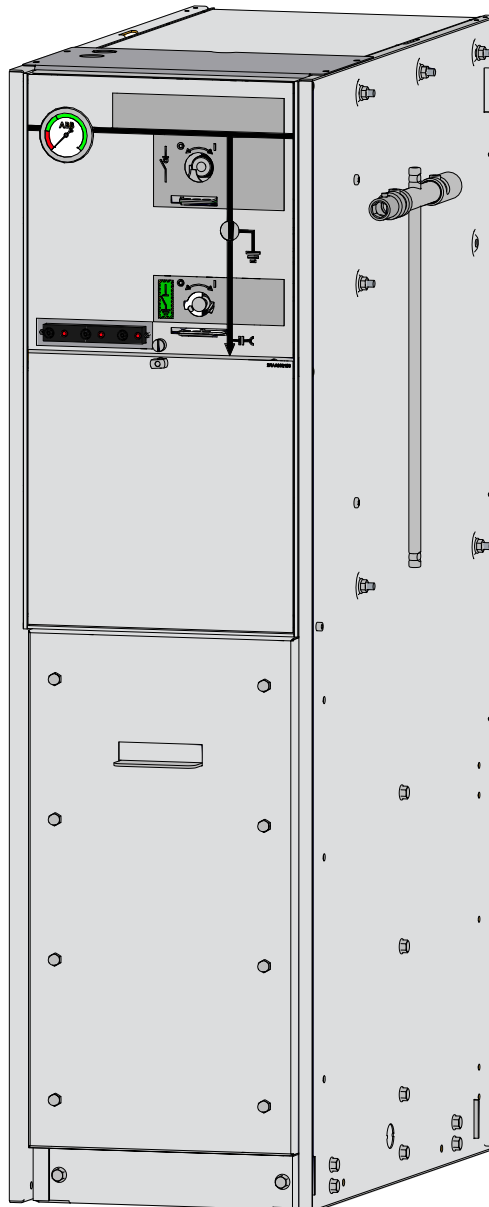

7.2.1 C - Cable switch module - Technical data

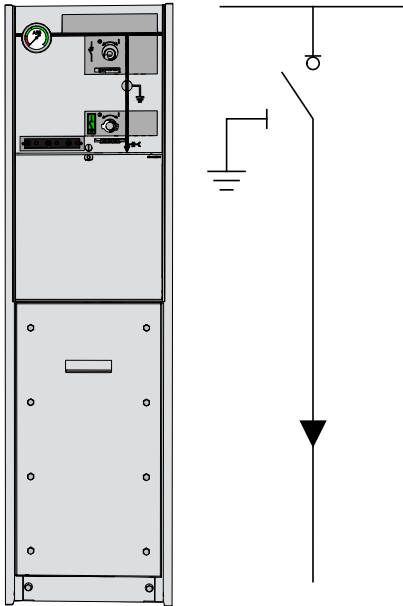

Depth: 751 mm
 Width: 325 mm
 Height: 1336 mm / optional 1100 mm

Common features

All modules share many common features. These are described in the chapter "SafeRing/SafePlus configurations".

Standard features

- Three position load break switch with disconnecter and earthing switch
- Operating mechanism with two separate operating shafts for load break function and earthing function
- Switch position indication for load break switch and earthing switch
- Cable bushings horizontal in front, Interface C (400 series bolted) with integrated voltage divider for voltage indication

Technical data

Switch disconnecter

Rated voltage	kV	12	17.5	24
Power frequency withstand voltage	kV	28 ¹⁾	38	50
Impulse withstand voltage	kV	95	95	125
Rated normal current	A	630	630	630
Breaking capacities:				
- active load	A	630	630	630
- closed loop	A	650	650	650
- off load cable charging	A	140	140	140
- earth-fault	A	205	160	160
- earth-fault cable charging	A	117	91	91
Making capacity	kA	62.5	52.5	52.5
Short time current 3 sec.	kA	25	21	21
Number of mechanical operations	1000 close / open manual			
Electrical and mechanical classes	E3, C2, M1			

Earthing switch

Rated voltage	kV	12	17.5	24
Power frequency withstand voltage	kV	28 ¹⁾	38	50
Impulse withstand voltage	kV	95	95	125
Making capacity	kA	62.5	50	50
Short time current 3 sec.	kA	25	21	21
Number of mechanical operations	1000 close / open manual			
Electrical and mechanical classes	E2, M0			

1) GOST version is available with 42kV power frequency withstand voltage

Optional features

- Bushings for top extension
- Bushings for side connection
- Bushings for side extension (400 A)
- Bushings for cable testing (including earthing device test points)
- Cable bushings:
 - Interface B (400 series plug-in, $I_n = 400$ A)
 - Interface C (400 series bolted) combisensors with integrated capacitor for voltage indication and sensors for current and voltage monitoring
 - Interface D (600 series bolted)
- Arc suppressor with signal (INO) wired to terminals (only on incoming feeder)
- Arc proof solution (see chapter "Safety")
- Signal (INO) from internal pressure indicator wired to terminals (only one each SF₆ gas tank)
- Latched single spring mechanism



Optional features also available as retrofit

- Motor operation for load break switch
- Low voltage compartment / top entry box

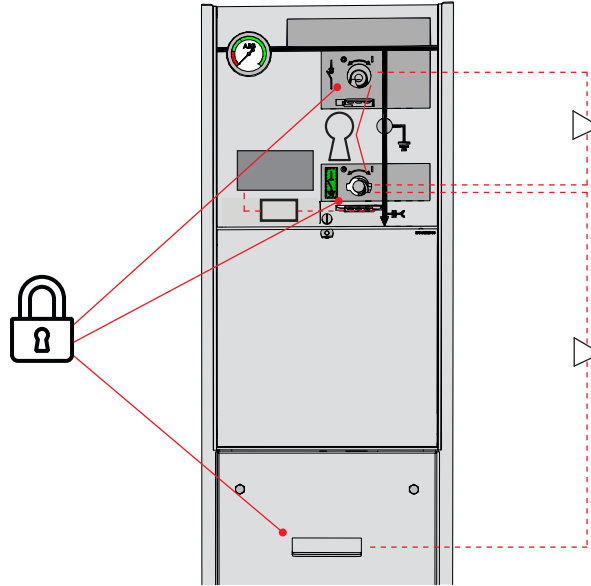
7.2.2 C - Cable switch module - Interlocking

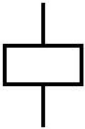

Abbreviations	
LBS	Load break switch
ES	Earthing switch
CB	Circuit breaker
SD	Switch-disconnector
SF	Switch-fuse

Interlock type	Operation	Condition	Comment
Mechanical interlock C-module 	Closing LBS	ES is open, cable compartment cover is on	Cable compartment interlock is optional
	Opening LBS	ES is open	Standard
	Closing ES	LBS is open	Standard
	Opening ES	LBS is open	Standard
	Opening cable compartment	ES is closed	Optional feature
	Opening cable test door	ES is closed	Optional feature (see chapter 21)
Electrical interlock C-module 	Remote operation of LBS	Gas pressure in tank is under threshold	Optional feature. Manometer with signalling contact, contact can be used only for signalling purposes
	Closing ES	Incoming cable is without voltage	Optional feature. Voltage presence System with signalling contact is required.
Padlocks C-module Padlocks to be provided by customer 	Lock on LBS	None	Standard feature (Diameter of padlock: 4 -8 mm)
	Lock on ES	None	Standard feature (Diameter of padlock: 4 -8 mm)
	Lock on local push buttons	None	Optional feature (Diameter of padlock: 4 -8 mm)
Key interlock C-module 	Key lock on LBS	See details in chapter "Key interlock"	Optional feature
	Key lock on LBS	See details in chapter "Key interlock"	Optional feature

7.3 F - Switch-fuse module

The switch-fuse (F-module) includes a three position and earthing switch similar to the cable switch (C-module). By means of the fuse tripping device it operates as a switch-fuse combination. There is a double earthing switch which, when in the earth position connects earth to both sides of the fuse-links simultaneously. Both earthing switches are operated in one operation. The switch-fuse and earthing switch is mechanically interlocked to prevent hazardous access to the fuse-links. The lower cover which gives access to the fuse-links is also mechanically interlocked with the earthing switch.

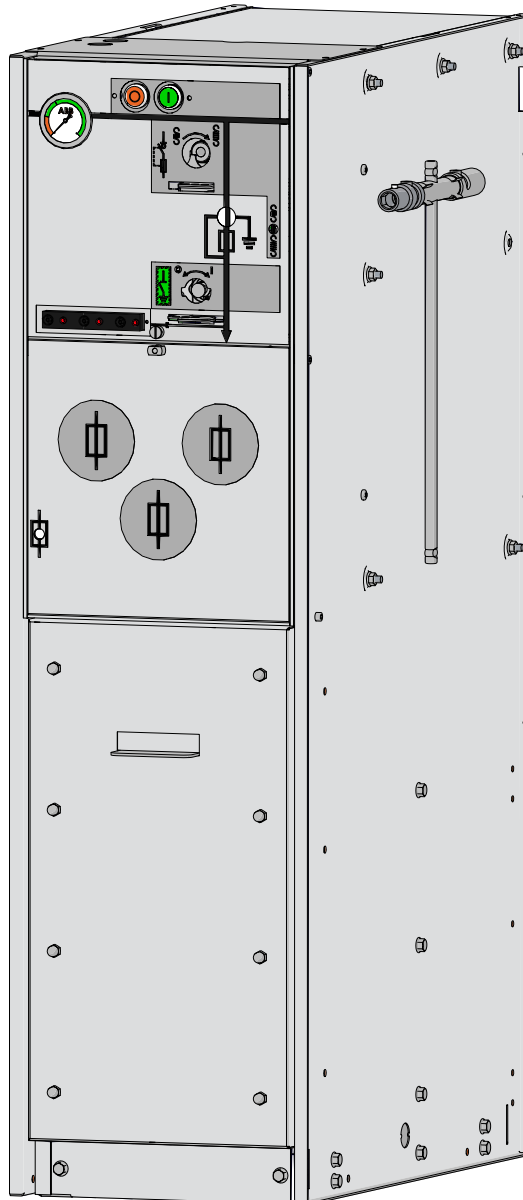

7.3.1 F - Switch-fuse module - Technical data

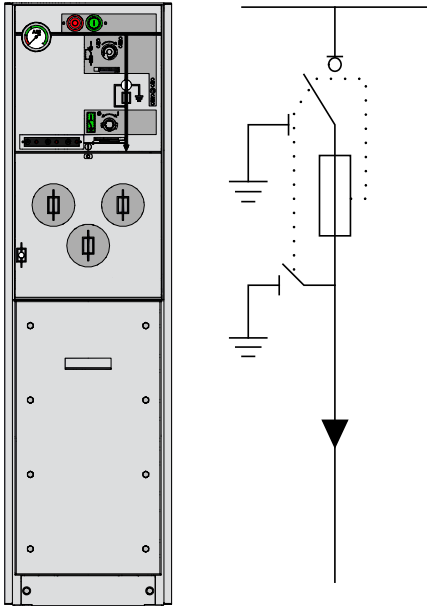

Depth: 751 mm
 Width: 325 mm
 Height: 1336 mm / optional 1100 mm

Common features

All modules share many common features. These are described in the chapter "SafeRing/SafePlus configurations".

Standard features

- Three position switch-fuse-disconnector with upstream earthing switch mechanically linked with downstream earthing switch
- Switch position indication for switch-fuse-disconnector and earthing switches
- Operating mechanism with double spring for switch-fuse-disconnector function
- Common mechanism for earthing functions
- Fuse canisters for DIN type fuse. Only accessible when earthing switches are closed
- Fuse-link / transformer rating:
 - 12 kV, max 125 A CEF fuses
 - 24 kV, max 63 A CEF fuses
- Fuse tripping arrangement
- Optical fuse trip indication

Technical data

Switch-fuse-disconnector				
Rated voltage	kV	12	17.5	24
Power frequency withstand voltage	kV	28 ²⁾	38	50
Impulse withstand voltage	kV	95	95	125
Rated normal current	A	200	200	200
Breaking capacities:				
- off load transformer	A	20	20	20
Making capacity	kA	¹⁾	¹⁾	¹⁾
Number of mechanical operations	1000 close / open manual			
Electrical and mechanical classes	E3, M1			
Earthing switch downstream				
Rated voltage	kV	12	17.5	24
Power frequency withstand voltage	kV	28 ²⁾	38	50
Impulse withstand voltage	kV	95	95	125
Making capacity	kA	12.5	12.5	12.5
Short time current 1 sec.	kA	5	5	5
Number of mechanical operations	1000 close / open manual			
Electrical and mechanical classes	E2, M0			

1) Limited by high-voltage fuse-links

2) GOST version is available with 42kV power frequency withstand voltage

For fuse selection tables and transformer protection, see chapter "Fuse-links".

Optional features

- Bushings for side extension (400 A)
- Cable bushings:
 - Interface B (400 series plug-in, $I_n = 400A$)
 - Interface C (400 series bolted)
 - Interface C (400 series bolted) combisensors with integrated screen for voltage indication and sensors for current and voltage monitoring
- Signal (INO) from internal pressure indicator wired to terminals (only one each SF₆ gas tank)
- Arc proof solution (see chapter "Safety")

Optional features also available as retrofit

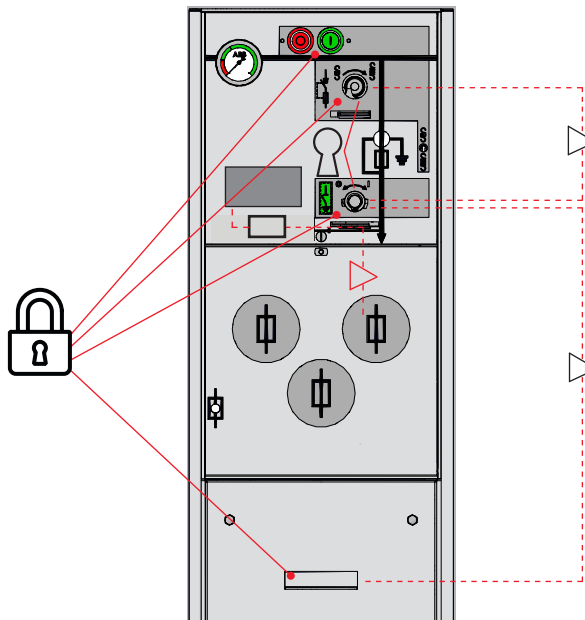

- Motor operation for switch-fuse-disconnector
- Auxiliary switches for load break switch position, earthing switch position and fuse blown
- Trip coil open
- Trip coil open and close

7.3.2 F - Switch-fuse module - Interlocking

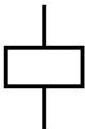

Abbreviations

LBS	Load break switch
ES	Earthing switch
CB	Circuit breaker
SD	Switch-disconnector
SF	Switch-fuse

Interlock type	Operation	Condition	Comment
 Mechanical interlock F-module	Closing SF	ES is open, fuse striker pin has not triggered, cable compartment cover is on	Cable compartment interlock is optional
	Opening SF	ES is open	Standard
	Closing ES	SF is open, fuse door panel is closed	Standard
	Opening ES	SF is open, fuse door panel is closed	Standard
	Opening fuse door panel	ES is closed	Standard
	Closing fuse door panel	ES is closed	Standard
	Opening cable compartment	ES is closed	Optional feature
	Closing cable compartment	ES is closed	Optional feature
 Electrical interlock F-module	Closing ES	Incoming cable is without voltage	Optional feature. Voltage presence System with signalling contact is required.
 Padlocks F-module Padlocks to be provided by customer	Lock on SF	None	Standard feature (Diameter of padlock: 4 -8 mm)
	Lock on ES	None	Standard feature (Diameter of padlock: 4 -8 mm)
	Lock cable compartment cover in closed position	None	Optional feature (Diameter of padlock: 4 -8 mm)
	Lock cable compartment cover in open position	None	Optional feature (Diameter of padlock: 4 -8 mm)
	Lock on push buttons	None	Optional feature (Diameter of padlock: 4 -8 mm)
 Key interlock F-module	Lock on SF		
	Key lock on ES	See details in chapter "Key interlock"	Optional feature

7.4 V - Vacuum circuit-breaker module

The vacuum circuit-breaker (V-module) has vacuum bottles as interrupters of the current. The modules includes a three-position disconnect/earthing switch that is connected downstream and in series with the circuit-breaker. The operation between vacuum circuit-breaker and disconnect/earthing switch is mechanically interlocked.

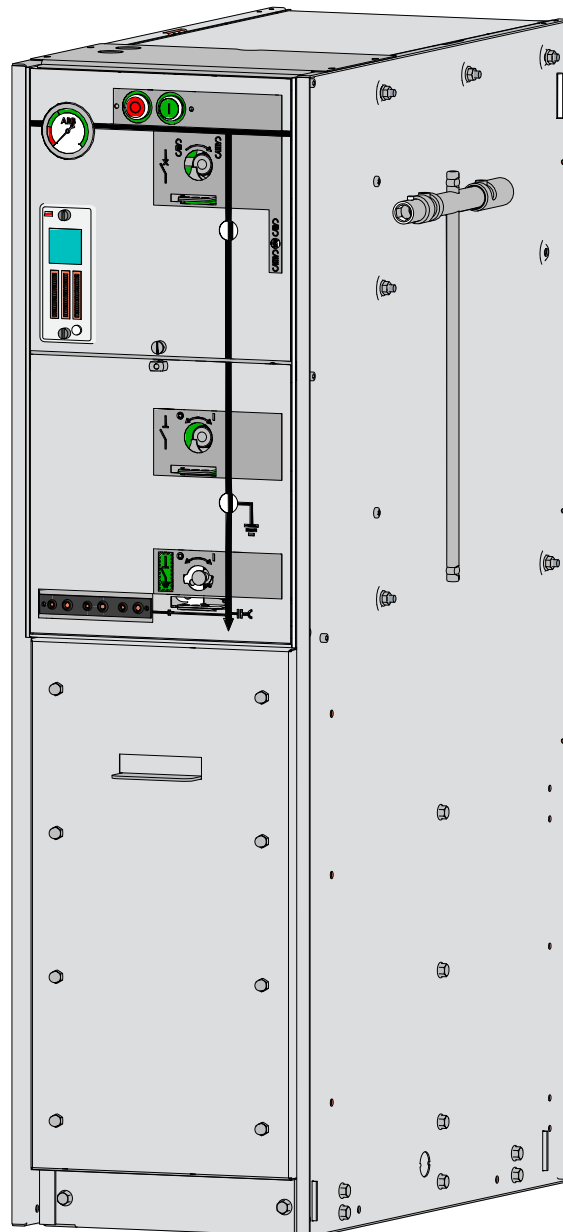

7.4.1 V - Vacuum circuit-breaker module - Technical data

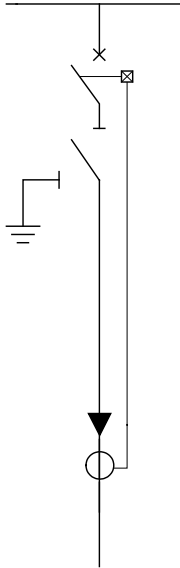
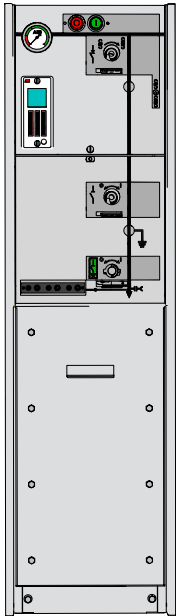

Depth: 751 mm
 Width: 325 mm
 Height: 1336 mm / optional 1100 mm

Technical data

Vacuum circuit-breaker

Rated voltage	kV	12	17.5	24
Power frequency withstand voltage	kV	28 ¹⁾	38	50
Impulse withstand voltage	kV	95	95	125
Rated normal current	A	200 / 630 ²⁾		
Breaking capacities:				
- short-circuit breaking current	kA	21	16	16
Making capacity	kA	52.5	40	40
Short time current 3 sec. ³⁾	kA	21	16	16
Number of mechanical operations	2000 close / open manual			

Electrical and mechanical classes:

E2, C2, S1, M1 for operating sequence O - 3min - CO - 3min - CO

Downstream disconnector and earthing switch

Rated voltage	kV	12	17.5	24
Power frequency withstand voltage	kV	28 ¹⁾	38	50
- across disconnector	kV	32	45	60
Impulse withstand voltage	kV	95	95	125
- across disconnector	kV	110	110	145
Making capacity	kA	52.5	40	40
Short time current 3 sec.	kA	21	16	16
Number of mechanical operations	1000 close / open manual			
Electrical and mechanical classes	E2, M0			

1) GOST version is available with 42kV power frequency withstand voltage

2) Depend on type of used bushing

3) Interface A - 12.5kA/1s, Interface B - 16kA/1s

Common features

All modules share many common features. These are described in the chapter "SafeRing/SafePlus configurations".

Standard features

- 200 A vacuum circuit-breaker for transformer protection or 630 A vacuum circuit-breaker for feeder protection
- Two position double spring mechanism for vacuum circuit-breaker
- Three position disconnector/earthing switch downstream from circuit-breaker
- Three position single spring mechanism for disconnector/earthing switch
- Interlocking between vacuum circuit-breaker and disconnector/earthing switch
- Switch position indication for vacuum circuit-breaker and disconnector/earthing switch
- Self-powered electronic protection relay with ring core CT's on cables (only standard on 200 A)
- Trip coil (for relay tripping)
- Cable bushings horizontal in front with integrated capacitor for voltage indication: Interface A (200 series plug-in) for 200 A vacuum circuit-breaker and interface C (400 series bolted) for 630 A vacuum circuit-breaker

Optional features

- Cable bushings:
 - Interface B (400 series plug-in)
 - Interface D (600 series bolted)
 - Interface C (400 series bolted) combisensors with integrated voltage divider for voltage indication and integrated sensor for current and voltage monitoring
- Arc suppressor with signal (1NO) wired to terminals
- Arc proof solution (see chapter "Safety")
- Signal (1NO) from internal pressure indicator wired to terminals (only one each SF₆ gas tank)



Optional features also available as retrofit

- Motor operation for vacuum circuit-breaker
- Auxiliary switches: vacuum circuit breaker position 2NO+2NC, disconnector position 2NO+2NC, earthing switch position 2NO+2NC and vacuum circuit-breaker tripped signal 1NO
- Blocking coil for earthing switch
- Undervoltage release with/without time delay

7.4.2 V - Vacuum circuit-breaker module - Interlocking

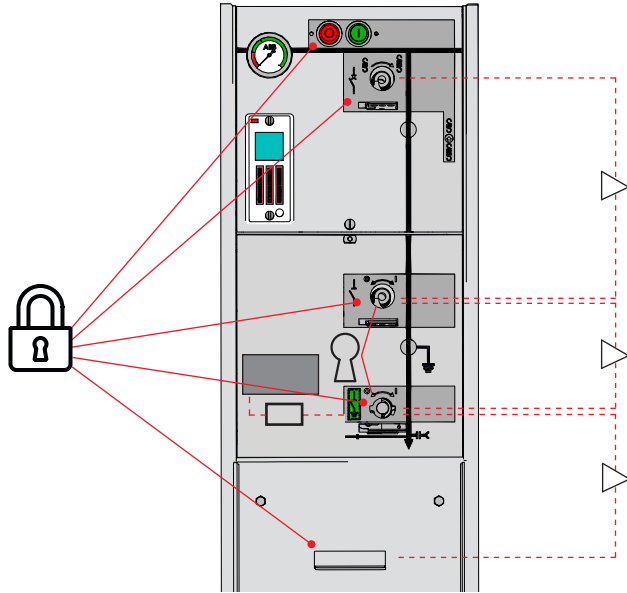
Abbreviations	
LBS	Load break switch
ES	Earthing switch
CB	Circuit breaker
SD	Switch-disconnector
SF	Switch-fuse

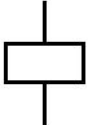

Interlock type	Operation	Condition	Comment
Mechanical interlock V-module 	Closing CB	None	
	Opening CB	None	
	Closing SD	CB is open, ES is open, cable compartment cover is on	Cable compartment interlock is optional
	Opening SD	CB is open, ES is open	Standard
	Closing ES	SD is open	Standard
	Opening ES	SD is open	Standard
	Opening cable compartment	ES is closed	Optional feature
	Closing cable compartment	ES is closed	Optional feature
	Electrical interlock V-module 	Closing ES	Incoming cable is without voltage
Padlocks V-module Padlocks to be provided by customer 	Lock on ES	None	Standard feature (Diameter of padlock: 4 -8 mm)
	Lock on CB	None	Standard feature (Diameter of padlock: 4 -8 mm)
	Lock on SD	None	Standard feature (Diameter of padlock: 4 -8 mm)
	Lock on push buttons	None	Optional feature (Diameter of padlock: 4 -8 mm)
	Lock cable compartment cover in closed position		Optional feature (Diameter of padlock: 4 -8 mm)
	Lock cable compartment cover in open position	None	Optional feature (Diameter of padlock: 4 -8 mm)
Key interlock V-module 	Key lock on SD	See details in chapter "Key interlock"	Optional feature
	Key lock on ES	See details in chapter "Key interlock"	Optional feature

7.5 V20/V25 - High duty vacuum circuit-breaker module

The high duty vacuum circuit-breaker module uses vacuum bottles to interrupt the current. A three-position disconnect/earthing switch is connected downstream and in series with the circuit-breaker. The operation between vacuum circuit-breaker and disconnect/earthing switch is mechanically interlocked.

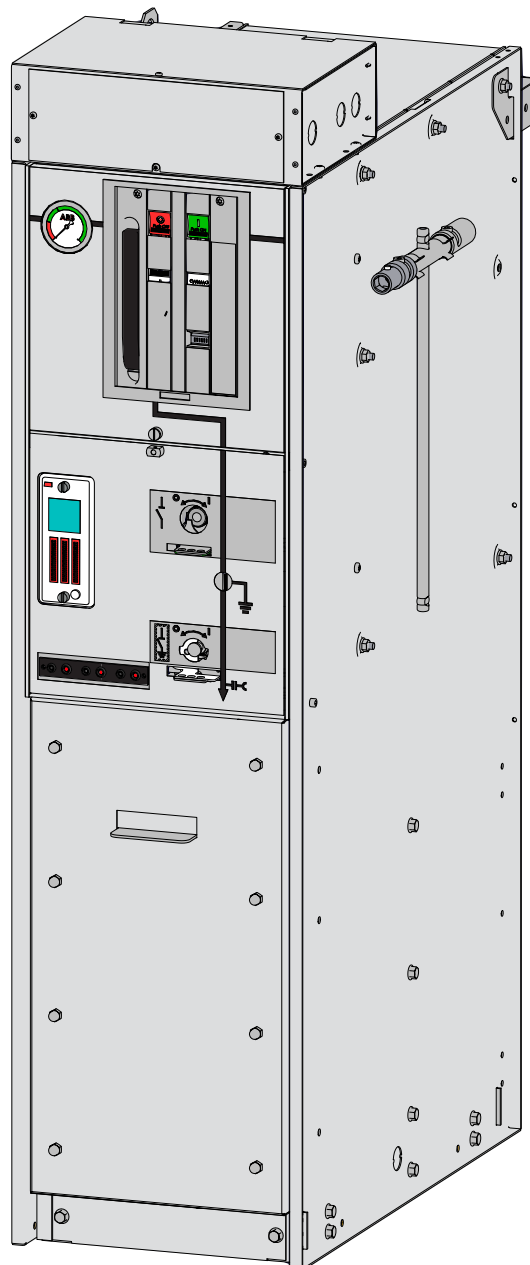

7.5.1 V20/V25 - High duty vacuum circuit-breaker module

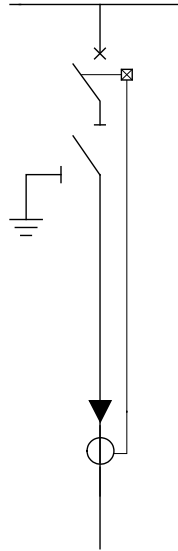
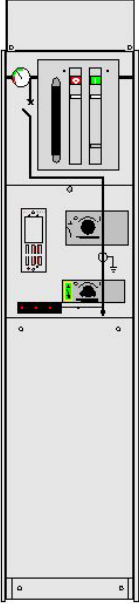

Depth: 751 mm
 Width: 325 mm
 Height: 1460 mm / optional 1226 mm

Common features

All modules share many common features. These are described in the chapter "SafeRing/SafePlus configurations".

Standard features

- 630 A vacuum circuit-breaker for feeder protection
- Mechanism with operating sequence;
O – 0.3 s – CO – 15 s – CO
- Auto-reclosing capability
- Vacuum circuit-breaker with downstream three-position disconnector/earthing switch
- Three-position single spring mechanism for disconnector/earthing switch
- Interlocking between vacuum circuit-breaker and disconnector/earthing switch
- Switch position indication for vacuum circuit-breaker and disconnector/earthing switch
- Mechanical counter
- Cable bushings horizontal in front Interface C (400 series bolted) with integrated capacitor for voltage indication
- Cable compartment cover allowing surge arrester or double cable connection

Technical data

Vacuum circuit-breaker				
Rated voltage	kV	12	17.5	24
Power frequency withstand voltage	kV	28 ¹⁾	38	50
Impulse withstand voltage	kV	95	95	125
Rated frequency ²⁾	Hz	50/60		
Rated normal current	A	630	630	630
Breaking capacities:				
- short-circuit breaking current	kA	25	20	20
Making capacity	kA	62.5	50	50
Short time current 3 sec.	kA	25	20	20
Number of mechanical operations	2000 close / open			
Electrical and mechanical classes:				
E2, C2, S1, M1 for operating sequence O - 0.3s - CO - 15s - CO ³⁾				
Optional:				
E2, C2, S1, M2 for operating sequence O - 0.3s - CO - 15s - CO				

Downstream disconnector and earthing switch

Rated voltage	kV	12	17.5	24
Power frequency withstand voltage	kV	28	38	50
- across disconnector	kV	32	45	60
Impulse withstand voltage	kV	95	95	125
- across disconnector	kV	110	110	145
Making capacity	kA	62.5	50	50
Short time current 1 sec.	kA	25	21	21
Short time current 3 sec.	kA	25	21	21
Number of mechanical operations	1000 close / open manual			
Electrical and mechanical classes	E2, M0			

1) GOST version is available with 42kV power frequency withstand voltage

2) De-rating for current parameters needs to be applied for 60Hz

3) EL2 mechanism combined with VG5 vacuum-bottles gives electrical and mechanical class: E1, C2, S1, M1 for operating sequence O-0.3s-CO-3min-CO

Optional features as factory mounted

- Cable bushings:
 - Interface C (400 series bolted) combi sensors with integrated voltage divider for voltage indication and integrated sensor for current and voltage monitoring
- Arc proof solution (see chapter "Safety")
- Arc suppressor with signal (1NO) wired to terminals

Optional features also available as retrofit

- Motor operation for vacuum circuit-breaker
- Auxiliary switches: Vacuum circuit breaker position 2NO+2NC, disconnector position 2NO+2NC, earthing switch position 2NO+2NC
- Undervoltage release with/without time delay
- Blocking magnet to prevent unintended operation
- Advanced relays type REF, RET and RED

Interlocking

- The rules are the same as for the standard V-module except for lockable push buttons.

7.6 SI - Busbar sectionalizer module

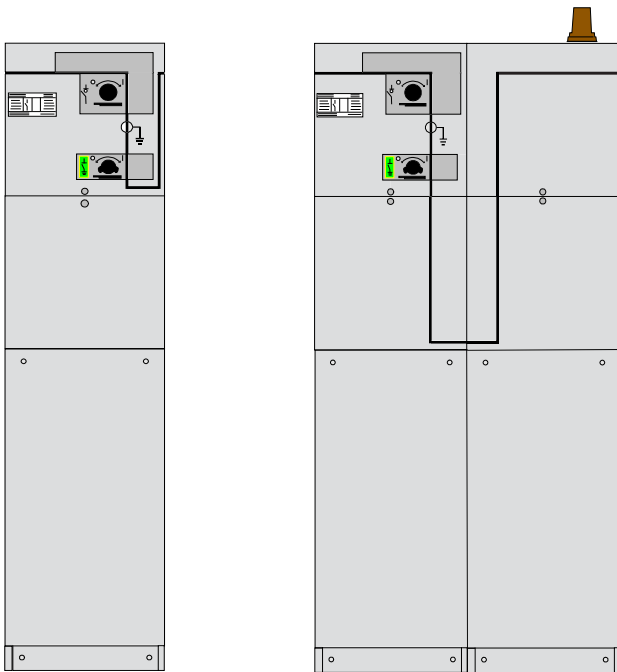

Depth: 751 mm
Width: 325 mm
Height: 1336 mm /
optional 1100 mm

Depth: 751 mm
Width: 650 mm
Height: 1336 mm /
optional 1100 mm

Extension is needed when
SI-module is the last module
in one common SF₆ gas tank

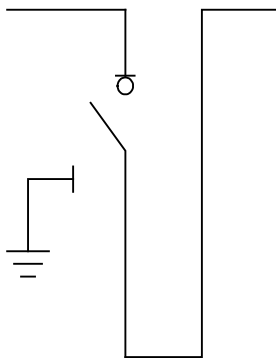

Technical data

Busbar sectionalizer SI

Rated voltage	kV	12	17.5	24
Power frequency withstand voltage	kV	28 ¹⁾	38	50
Impulse withstand voltage	kV	95	95	125
Rated normal current	A	630	630	630
Breaking capacities:				
- active load	A	630	630	630
- closed loop	A	670	670	670
- off load cable charging	A	141	141	141
- earth-fault	A	205	160	160
- earth-fault cable charging	A	117	91	91
Making capacity	kA	62.5	52.5	52.5
Short time current 3 sec.	kA	25	21	21
Number of mechanical operations	1000 close / open manual			
Electrical and mechanical classes	E3, C2, M1			

Earthing switch

Rated voltage	kV	12	17.5	24
Power frequency withstand voltage	kV	28 ¹⁾	38	50
Impulse withstand voltage	kV	95	95	125
Rated normal current	A	630	630	630
Making capacity	kA	62.5	50	50
Short time current 3 sec.	kA	21	21	21
Number of mechanical operations	1000 close / open manual			
Electrical and mechanical classes	E2, M0			

1) GOST version is available with 42kV power frequency withstand voltage

Common features

All modules share many common features. These are described in the chapter "SafeRing/SafePlus configurations".

Standard features

- Three position load break switch with disconnecter and earthing switch
- Operating mechanism with two separate operating shafts for load break function and earthing function
- Switch position indication for load break switch and earthing switch

Optional features

- Latched single spring mechanism
- Arc proof solution (see chapter "Safety")

Optional features also available as retrofit

- Motor operation for load break switch
- Auxiliary switches, load break switch position 2NO+2NC and earthing switch position 2NO+2NC
- Ronis key interlock

Interlocking

The rules are the same as for the C-module with the exception of the rules for the cable compartment cover.

7.7 Sv - Busbar sectionalizer module

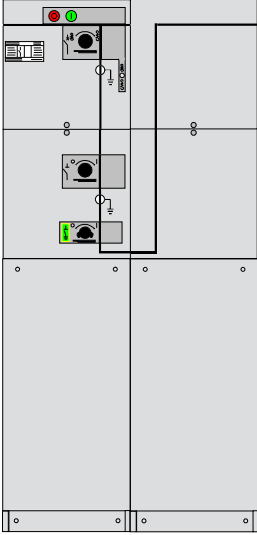

Depth: 751 mm
 Width: 650 mm
 Height: 1336 mm /
 optional 1100 mm

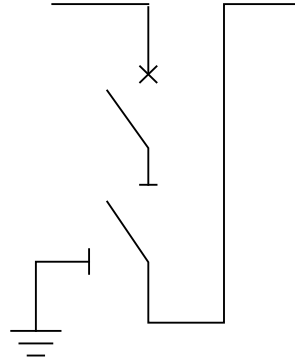

Sv is always in combination with busrise module (Br)

Technical data

Busbar sectionalizer Sv

Rated voltage	kV	12	17.5	24
Power frequency withstand voltage	kV	28 ¹⁾	38	50
Impulse withstand voltage	kV	95	95	125
Rated normal current	A	630	630	630
Breaking capacities:				
- short-circuit breaking current	kA	21	16	16
Making capacity	kA	52.5	40	40
Short time current 3 sec.	kA	21	16	16
Number of mechanical operations	2000 close / open manual			

Electrical and mechanical classes:

E2, C2, S1, M1 for operating sequence O - 3min - CO - 3min - CO

Downstream disconnector and earthing switch

Rated voltage	kV	12	17.5	24
Power frequency withstand voltage	kV	28 ¹⁾	38	50
- across disconnector	kV	32	45	60
Impulse withstand voltage	kV	95	95	125
- across disconnector	kV	110	110	145
Making capacity	kA	52.5	40	40
Short time current 3 sec.	kA	21	16	16
Number of mechanical operations	1000 close / open manual			
Electrical and mechanical classes	E2, M0			

1) GOST version is available with 42kV power frequency withstand voltage

Common features

All modules share many common features. These are described in the chapter "SafeRing/SafePlus configurations".

Standard features

- 630 A vacuum circuit-breaker
- Two position double spring mechanism for vacuum circuit-breaker
- Three position disconnector / earthing switch downstream from circuit-breaker
- Three position single spring mechanism for disconnector / earthing switch
- Interlocking between vacuum circuit-breaker and disconnector / earthing switch
- Switch position indication for vacuum circuit-breaker and disconnector / earthing switch

Optional features also available as retrofit

- Motor operation for vacuum circuit-breaker
- Auxiliary switches: vacuum circuit-breaker position 2NO+2NC, disconnector position 2NO+2NC and earthing switch position 2NO+2NC
- Arc proof solution (see chapter "Safety")
- Protection relay (metering module is required)
- Trip coil for relay trip
- Additional trip coil
- Undervoltage release with/without time delay

Interlocking

The rules are the same as for the standard V-module with the exception of the rules for the cable compartment cover.

7.8 Sv - Busbar sectionalizer module - Sv20/Sv25

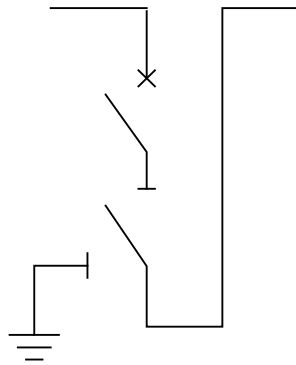
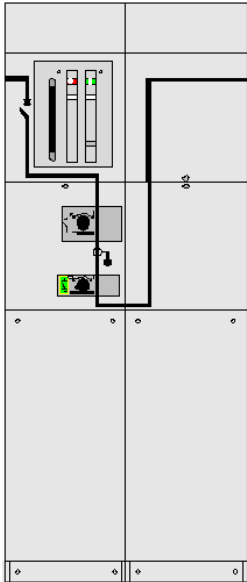

Depth: 751 mm
Width: 650 mm
Height: 1460 mm /
optional 1226 mm

Sv is always in combination
with busrise module (Br)

Technical data

Vacuum circuit-breaker

Rated voltage	kV	12	24
Power frequency withstand voltage	kV	28 ¹⁾	50
Impulse withstand voltage	kV	95	125
Rated normal current	A	630	630
Breaking capacities:			
- short-circuit breaking current	kA	25	20
Making capacity	kA	65	50
Short time current 3 sec.	kA	25	21
Number of mechanical operations	2000 close / open manual		

Electrical and mechanical classes SV20:

E1,C2,S1,M1 for operating sequence O - 0.3s - CO - 3min - CO

Electrical and mechanical classes SV25:

E2,C2,S1,M1 for operating sequence O - 0.3s - CO - 15s - CO

Downstream disconnector and earthing switch

Rated voltage	kV	12	24
Power frequency withstand voltage	kV	28 ¹⁾	50
- across disconnector	kV	32	90
Impulse withstand voltage	kV	95	125
- across disconnector	kV	110	145
Making capacity	kA	62.5	50
Short time current 1 sec.	kA	25	21
Short time current 3 sec.	kA	21 ²⁾	21
Number of mechanical operations	1000 close / open manual		
Electrical and mechanical classes	E2, M0		

1) GOST version is available with 42kV power frequency withstand voltage

2) 25kA available as option

Common features

All modules share many common features. These are described in the chapter "SafeRing/SafePlus wconfigurations".

Standard features

- 630 A vacuum circuit-breaker
- Vacuum circuit-breaker with downstream three-position disconnector/earthing switch
- Three position single spring mechanism for disconnector / earthing switch
- Interlocking between vacuum circuit-breaker and disconnector / earthing switch
- Switch position indication for vacuum circuit-breaker and disconnector / earthing switch

Optional features also available as retrofit

- Motor operation for vacuum circuit-breaker
- Low voltage compartment / Top entry box
- Auxiliary switches: vacuum circuit-breaker position 2NO+2NC, disconnector position 2NO+2NC and earthing switch position 2NO+2NC
- Arc proof solution (see chapter "Safety")
- Protection relay (metering module is required)
- Trip coil for relay trip
- Additional trip coil
- Undervoltage release with/without time delay

Interlocking

The rules are the same as for the standard V-module with the exception of the rules for the cable compartment cover.

7.9 D - Direct cable connection module

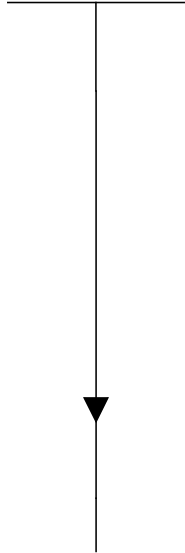
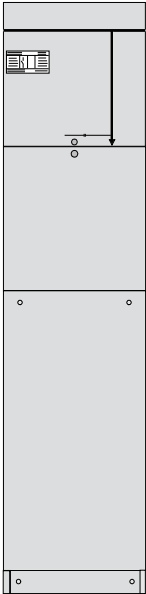

Technical data

Direct cable connection

Rated voltage	kV	12	17.5	24
Power frequency withstand voltage	kV	28 ¹⁾	38	50
Impulse withstand voltage	kV	95	95	125
Rated normal current	A	630	630	630
Short time current 3 sec.	kA	25	21	21

1) GOST version is available with 42kV power frequency withstand voltage

Depth: 751 mm

Width: 325 mm

Height: 1336 mm / optional 1100 mm

Common features

All modules share many common features.

These are described in the chapter "SafeRing/SafePlus configurations".

Optional features

- Bushings for connection of external busbars
- Cable bushings:
 - Interface B (400 series plug-in) (In = 400 A)
 - Interface C (400 series bolted) combisensors with integrated capacitor for voltage indication and sensors for current and voltage monitoring
 - Interface D (600 series bolted)
- Arc proof solution (see chapter "Safety")

Interlocking

Padlock on cable compartment cover (optional).

7.10 De - Direct cable connection module with earthing switch

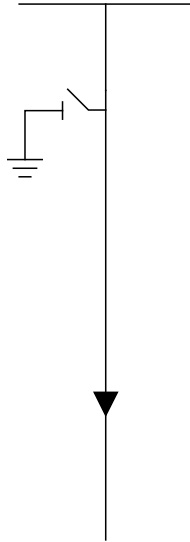
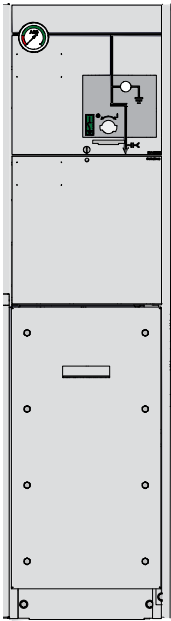

Technical data

Direct cable connection with earthing switch

Rated voltage	kV	12	17.5	24
Power frequency withstand voltage	kV	28 ¹⁾	38	50
Impulse withstand voltage	kV	95	95	125
Rated normal current	A	630	630	630
Making capacity	kA	62.5	50	50
Short time current 3 sec.	kA	25	21	21
Number of mechanical operations		1000 close / open manual		

1) GOST version is available with 42kV power frequency withstand voltage

Depth: 751 mm

Width: 325 mm

Height: 1336 mm / optional 1100 mm

Common features

All modules share many common features. These are described in the chapter "SafeRing/SafePlus configurations".

Standard features

- Earthing switch
- Two position single spring mechanism
- Switch position indication
- Cable bushings horizontal in front, Interface C (400 series bolted) with integrated capacitor for voltage indication



Optional features

- Bushings for cable testing, including earthing device
- Cable bushings:
 - Interface B (400 series plug-in) (In = 400 A)
 - Interface C (400 series bolted) combisensors with integrated capacitor for voltage indication and sensors for current and voltage monitoring
 - Interface D (600 series bolted)
- Interlocking of compartment for cable test bushings
- Arc proof solution (see chapter "Safety")

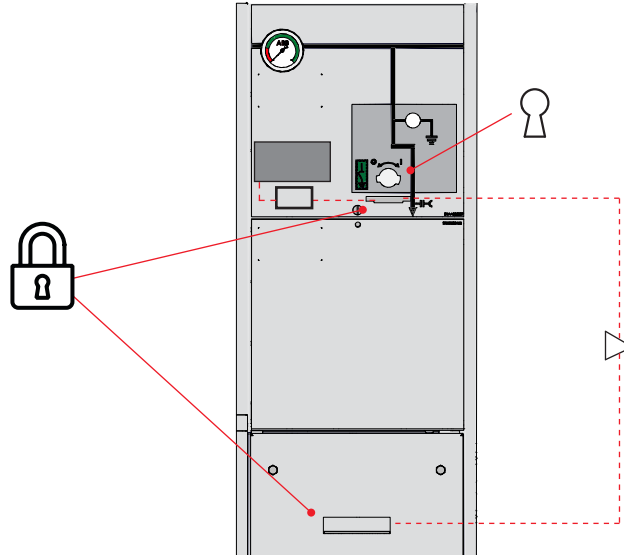
7.10.1 De-module - Interlocking

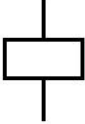

Abbreviations	
LBS	Load break switch
ES	Earthing switch
CB	Circuit breaker
SD	Switch-disconnector
SF	Switch-fuse

Interlock type	Operation	Condition	Comment
Mechanical interlock De-module 	Closing ES	None	
	Opening ES	None	
	Opening cable compartment	ES is closed	Optional feature
	Closing cable compartment	ES is closed	Optional feature
Electrical interlock De-module 	Closing ES	Incoming cable is without voltage	Optional feature. Voltage presence System with signalling contact is required.
Padlocks De-module Padlocks to be provided by customer 	Lock on ES	None	Standard feature (Diameter of padlock: 4 -8 mm)
	Lock cable compartment cover in closed position	None	Optional feature (Diameter of padlock: 4 -8 mm)
	Lock cable compartment cover in open position	None	Optional feature (Diameter of padlock: 4 -8 mm)
Key interlock De-module 	Key lock on ES	See details in chapter "Key interlock"	Optional feature

7.11 Be - Busbar earthing module

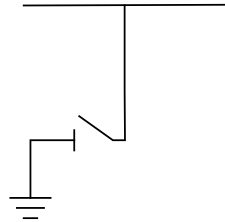
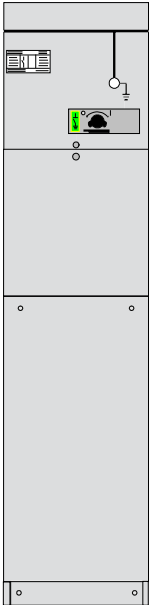

Technical data

Busbar earthing

Rated voltage	kV	12	17.5	24
Power frequency withstand voltage	kV	28 ¹⁾	38	50
Impulse withstand voltage	kV	95	95	125
Rated normal current	A	630	630	630
Making capacity	kA	62.5	50	50
Short time current 1 sec	kA	25		
Short time current 3 sec.	kA	21	21	21
Number of mechanical operations		1000 close / open manual		

¹⁾ GOST version is available with 42kV power frequency withstand voltage

Depth: 751 mm

Width: 325 mm

Height: 1336 mm / optional 1100 mm

Common features

All modules share many common features.

These are described in the chapter "SafeRing/SafePlus configurations".

Standard features

- Earthing switch
- Two position single spring mechanism
- Switch position indication for earthing switch

Optional features

- Arc proof solution (see chapter "Safety")

7.12 CB - Circuit-breaker module

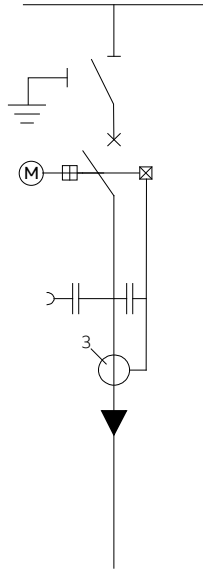
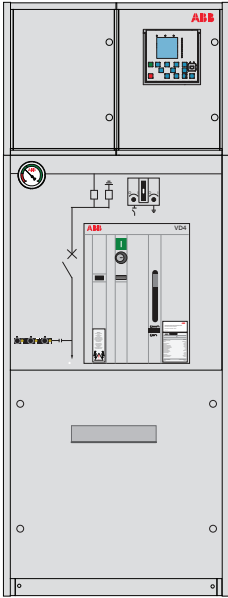

Technical data

Circuit-breaker module

Rated voltage	kV	12	17.5	24
Power frequency withstand voltage	kV	28	38	50
Impulse withstand voltage	kV	75	95	125
Rated normal current	A	630 / 1250 ¹⁾		
Breaking capacities:				
Short-circuit breaking current	kA	25	20	20
Making capacity	kA	62.5	50	50
Short time current 2 sec. - 630	kA	25	20	20
Short time current 3 sec. - 1250	kA	25	20	20
Number of mechanical operations	30000 close / open manual			
Electrical and mechanical classes	E2, C2, M2			
Operating sequence	O - 0.3s - CO - 15s - CO			

¹⁾ For 1250 variant combisensors can not be used

Depth: 800 mm
Width: 696 mm
Height: 1336 mm

Common features

All modules share many common features. These are described in the chapter "SafeRing/SafePlus configurations".

Standard features

- 630/1250A vacuum circuit breaker
- Disconnecter
- Earthing switch
- Bushings for connection of external busbars
- Auto reclosing sequence
- Closing and tripping coil
- Low voltage compartment with different protection relays
- Motor operated mechanism, circuit-breaker

Optional features also available as retrofit

- Motor operated disconnecter / earthing switch

A selection of configurable functions

Protection:

- Non-directional overcurrent protection, 3 stages
- Directional overcurrent protection, 3 stages
- Non-directional earth-fault protection
- Directional earth-fault protection
- Residual overvoltage protection
- 3-phase thermal overload
- 3-phase overvoltage protection
- Under- or over-frequency including rate of change, 5 stages

Measurement:

- 3-phase current
- Neutral current
- 3-phase voltage
- Residual voltage
- 3-phase power and energy including cos phi
- Transient disturbance recorder



Optional functionality

- Capacitor bank protection
- Capacitor bank control
- Power quality
- Auto changeover

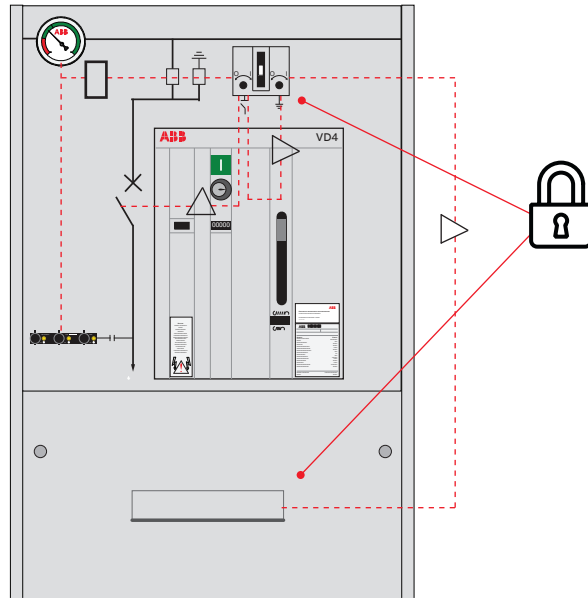
7.12.1 CB - Circuit-breaker module - Interlocking

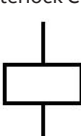

Abbreviations	
LBS	Load break switch
ES	Earthing switch
CB	Circuit breaker
SD	Switch-disconnector
SF	Switch-fuse

Interlock type	Operation	Condition	Comment
Mechanical interlock CB-module 	Closing CB	None	
	Opening CB	None	
	Closing SD	CB is open, ES is open, cable compartment cover is on	Cable compartment interlock is optional
	Opening SD	CB is open, ES is open	
	Closing ES	SD is open	
	Opening ES	SD is open	
	Opening cable compartment	ES is closed	Optional feature
	Closing cable compartment	ES is closed	Optional feature
	Electrical interlock CB-module 	Closing ES	Incoming cable is without voltage
Padlocks CB-module Padlocks to be provided by customer 	Lock cable compartment cover in closed position	None	Standard feature (Diameter of padlock: 4 -8 mm)
	Lock cable compartment cover in open position	None	Standard feature (Diameter of padlock: 4 -8 mm)

7.13 M - Metering module

- 01 Metering module busbar in/out, front view.
- 02 Metering module busbar in/out, side view.
- 03 Metering module busbar in/out, front view without CT's.

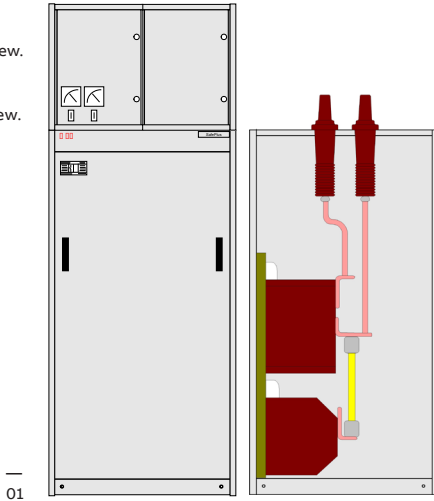

01

Depth: 802 mm
 Width: 696 mm
 Height: 1806 mm (with LV-compartment)

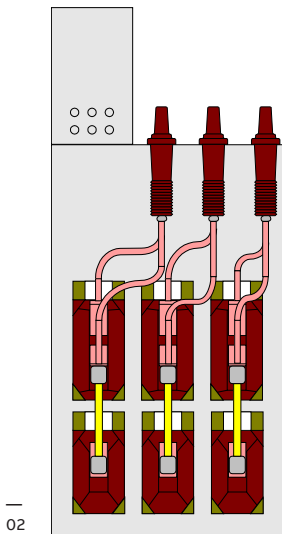

02

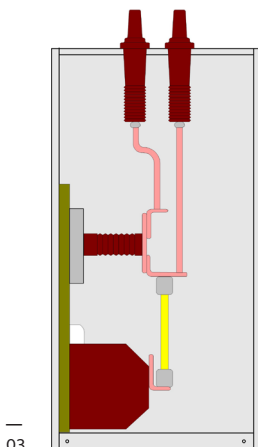

03

Technical data

Metering module

Rated voltage	kV	12	17.5	24
Power frequency withstand voltage	kV	28 ¹⁾	38	50
Impulse withstand voltage	kV	95	95	125
Rated normal current ²⁾	A	630	630	630
Short time current 1 sec	kA	25		
Short time current 3 sec.	kA	21	21	21

¹⁾ GOST version is available with 42kV power frequency withstand voltage

²⁾ Limited by primary current of the current transformers

The M-module is a factory assembled, type tested, air insulated metering cubicle with conventional CTs and VTs. The M-module is designed for CTs and VTs with dimensions according to DIN 42600 Narrow type.

Standard features

- 2 or 3 pcs (has to be specified) DIN 42600 Narrow type current transformers with ribs
- 3 pcs DIN 42600 Narrow type single pole voltage transformers
- 6 pcs bushings Interface C (400 series bolted) with connections and external busbars for SafePlus modules on left- and right-hand side
- 3 pcs bushings Interface C (400 series bolted) only required if the M-module is left-hand side or right-hand side end module
- Internal layout with CTs and VTs on left-hand side or right-hand side dependent of power direction (has to be specified)
- Padlock interlocking, to prevent access to live parts

Voltage transformers

- Single pole insulated with measuring and earth-fault windings
- A wide range of VTs are available that can be selected to meet our customers requirements
- Note: VTs can also be delivered without open Delta Earth fault windings

Current transformers

- Single-core or double-core design
- Secondary side reconnectable is possible
- A wide range of CTs are available that can be selected to meet our customers requirements

See chapter 9 for more information or contact your local ABB representative.

—
01 Metering module busbar in/cable out, front view.

—
02 Metering module busbar in/cable out, front view without CT's.

—
03 Metering module busbar in, front view.

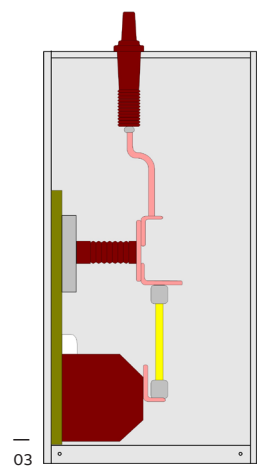
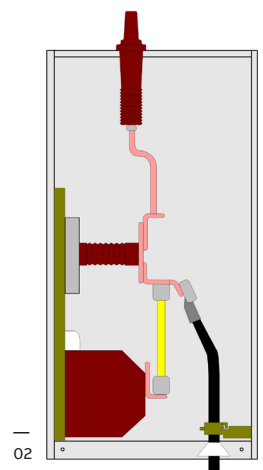
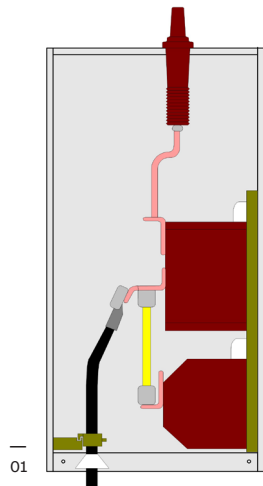

Low voltage compartment

- Terminals for voltage transformers' secondary connection
- 3-pole MCB (Miniature Circuit Breaker) for measuring voltage
- 1-pole MCB for earth-fault voltage
- Damping resistor for voltage transformers open delta earth fault windings to avoid ferroresonance
- Separating terminals for current transformers' secondary windings
- Space for electronic kWh-meter

Optional features

- Primary fuses for voltage transformers
- Voltmeter with selector switch, 6 positions +0
- A-meter with selector switch, 3 positions +0
- Additional meters
- Ronis key interlocking to prevent access to live parts
- Cable entry from bottom for incoming or outgoing cables
- Metering module delivered for voltage measuring only
- Metering module delivered without low voltage equipment and wiring
- Metering module delivered without VTs and CTs, with connections only
- Arc proof solution AFL 20kA 0.5s available for busbar in/out configuration

Optional features also available as retrofit

- Base frame (290 or 450 mm)

7.14 Mt - Metering tariff module

01 Metering tariff module bottom cable in/out, front view.

02 Metering tariff module bottom cable in/top right side cable out, front view.

03 Metering tariff module bottom cable in/ top left side cable out, front view.

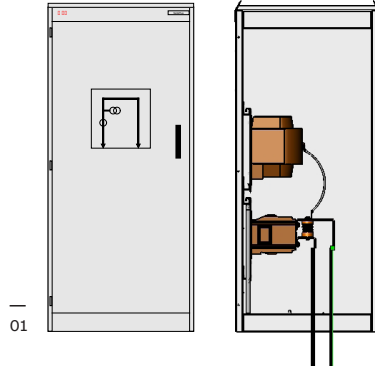

Depth: 1047 mm
Width: 800 mm
Height: 1806 mm

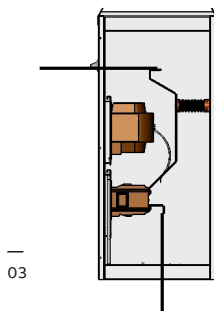
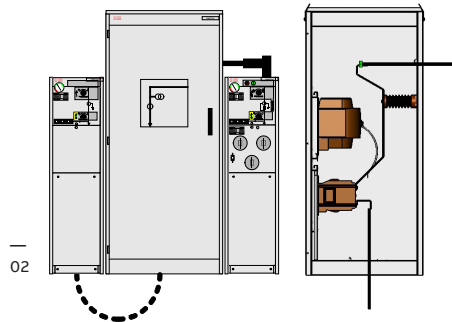

Technical data

Metering tariff module

Rated voltage	kV	12	24
Power frequency withstand voltage	kV	28 ¹⁾	50
Impulse withstand voltage	kV	95	125
Rated normal current ²⁾	A	630	630
Short time current 1 sec.	kA	20	20

1) GOST version is available with 42kV power frequency withstand voltage

2) Limited by primary current of the current transformers

The Mt-module is a factory assembled, type tested, air insulated non-arc proof metering cubicle with conventional CTs and VTs. The Mt-module is designed for CTs and VTs with dimensions according to DIN 42600 Narrow type and for installation of transformers locally.

The Mt-module is manufactured and tested according to IEC 62271-200. It is available in 3 versions:

- Bottom cable in/out
- Left side top connection for outgoing cable, bottom cable in
- Right side top connection for outgoing cable, bottom cable in

Standard features

- 3 pcs DIN 42600 Narrow type current transformers with ribs
- 3 pcs DIN Narrow type single pole voltage transformers
- Padlock interlocking to prevent access to live parts
- MV cable connection to SafePlus cubicle using 3M, Euromold/Elastimold, NKT, Pirelli, Raychem etc. connectors
- MV cable connection inside Mt-module by conventional cable lugs

Voltage transformers

- Single pole insulated with measuring and earth-fault windings
- A wide range of VTs are available that can be selected to meet our customers requirements
- Note: VTs can also be delivered without open Delta Earth fault windings

Current transformers

- Single-core or double-core design
- Secondary side reconnectable is possible
- A wide range of CTs are available that can be selected to meet our customers requirements

See chapter 9 for more information or contact your local ABB representative.

7.15 Side metering

01 Side connected metering. Measuring voltage on the cable-in side. This solution is non-arc proof only. Installation on base frame not possible.

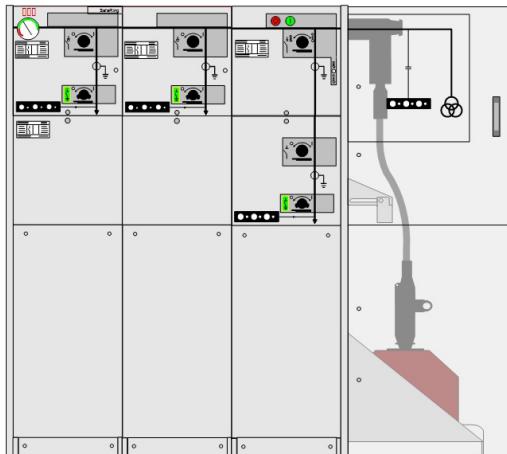

01

Technical data

Metering module

Rated voltage	kV	12	24
Power frequency withstand voltage	kV	28 ¹⁾	50
Impulse withstand voltage	kV	95	125
Short time current 1 sec	kA	25	
Short time current 3 sec.	kA	21	21

¹⁾ GOST version is available with 42kV power frequency withstand voltage

The side metering module is a factory assembled, type tested, air insulated metering cubicle with conventional VTs for busbar voltage metering.

Standard features

- 3 pcs of ELEQ UGECAL single phase voltage transformers
- Layout with module on left-hand side or right-hand side (has to be specified)
- 3 pcs bushings Interface C (400 series bolted) for connections of cables on left- or right-hand side
- Permanent fixed cover to prevent access to live parts

Optional features

- 1 pcs Artech VEG-24 touch-proof type, phase-phase voltage transformer (only available for 24kV)
- Voltage indication system (VDS or VPIS)

7.16 Mini-metering (integrated metering)

01 For this solutions, either a base-frame or cable trench is needed. The switch-gear is equipped with special support bars for transport.

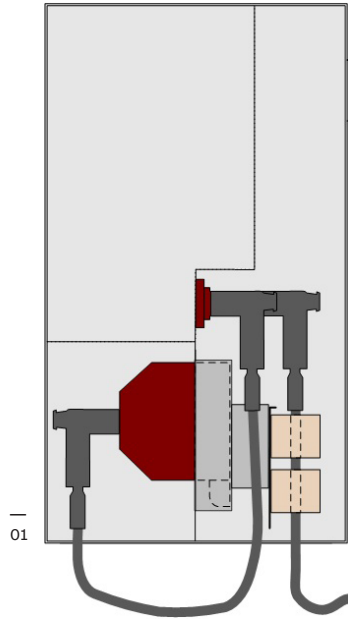

Features

- Ring main unit configurations such as CCVm with breaker and CCFm with fuses
- Solution is available for 3- or 4-way units for 12 and 24kV
- The measurement has to be taken from the right-hand side
- No need for separate metering module in typical ring main unit applications with one incoming/outgoing feeder

Integrated voltage and current transformers used for tariff metering.

- CTs Class 0.2S
- VTs Class 0.2 (touch proof design)

Customer benefits

- Space saving with one common SF₆ gas tank solution
- Arc suppressors in cable switch panels for increased personnel safety
- Manometer with visible indication of arc suppressor
- Factory mounted solution with integrated VTs & CTs for reduced installation time on site
- Compact dimensions
- Cost saving with reduced footprint
- Standard design with short lead time
- Arc-proof tested solution

8 Current transformers

Toroidal current transformers

Toroidal transformers are insulated either in epoxy-resin or encapsulated in a plastic housing. They are used either for power measuring devices or protection relays.

These transformers can be closed or split-core type. They can be used for measuring phase currents and detecting earth-fault currents. They conform to standard IEC 61869-1.

KOKM 072 xA 10 – These indoor ring core current transformers supply metering and protection devices at a maximum nominal voltage of 0.72 kV and nominal frequency of 50 or 60 Hz.

The transformers can be mounted inside the RMU switchgear. Secondary circuits can be connected using copper wires with a cross-section up to 4 mm² (strand) or up to 6 mm² (solid conductor). CTs with secondary current 0.075A are specially designed and applicable for use with self-powered relays.

KOLA and KOLMA are used for measurement of residual current (I_0).



KOKM 072



KOLMA



KOLA

Ring core current transformers and earth-fault transformers

Protection relay standard CT's typical	Ring core current transformer type	Ratio - burden
Transformer type: class 10P10	KOKM 072 or SVA 100-100-45	50-100-200/1 A 1.5/3/6 VA
Transformer type: class 5P10	KOKM 072 or SVA 100-100-45	150/1 A 4 VA
Transformer type: class 5P10	KOKM 072 or SVA 100-100-45	100-200/1 A 4 - 7 VA
Transformer type: class 5P10	KOKM 072 or SVA 100-100-45	300-600/1 A 4 - 7 VA
Transformer type: class 5P10	KOKM 072 or SVA 100-100-45	400-600/1 A 4 - 7 VA
Earth-fault transformer		
Earth-fault transformer, class 10P10, burden 0.5 - 15VA dependent on selected ratio	KOLMA 06A1 (90 mm)	Multi-tap secondary: 50-150/1 A or 50-750/5 A
Earth-fault transformer, class 10P10, burden 0.5 - 15VA dependent on selected ratio	KOLMA 06D1 (180 mm)	Multi-tap secondary: 50-150/1 A or 50-750/5
Earth-fault transformer, 0.5 - 20VA	KOLA 100 mm ring type	50 - 1600 A
Earth-fault transformer, 0.5 - 20VA	KOLA 180 mm ring type	50 - 1800 A
Earth-fault transformer, 0.5 - 5VA	KOLA 397 x 300 mm rectangular type	50 - 1250 A

Current transformers for self-powered relays, see chapter 24 "Relays"

9 Measuring transformers

Current transformers to DIN standards

The DIN current transformers are insulated in resin and are used for powering measuring and protection devices. These transformers can have a wound core with one or more cores and come with performance and precision classes that suit the requirements of the installation. These devices conform to standard IEC 61869-2. Their dimensions normally comply with standard DIN 42600 Narrow Type.

The current transformers can also be supplied with a capacitive socket for connection to voltage signalling devices. The ABB range of current transformers is called TPU.

TPU 4x.xx up to 12 kV
TPU 5x.xx up to 17.5 kV
TPU 6x.xx up to 24 kV

Voltage transformers

The voltage transformers are insulated in epoxy resin and are used for powering measuring and protection devices. They are available for fixed assembly or on a plug-in plate for panels with withdrawable circuit-breakers. In this case, the transformers can be equipped with a medium voltage protection fuse. They conform to standard IEC 61869-3. Their dimensions comply with standard DIN 42600 Narrow Type. These transformers can have one or two poles and possess performance and precision classes that suit the functional requirements of the instruments to which they are connected. The ABB range of voltage transformers is called TJC.

TJC 4x.xx up to 12 kV
TJC 5x.xx up to 17.5 kV
TJC 6x.xx up to 24 kV



10 Combisensors

Sensor variants

Two versions are available: one providing voltage measurement together with voltage indication capability or a second one providing both of these plus the possibility of current measurement (KEVCY 24 RE1).

Linearity

Due to the absence of a ferromagnetic core, the sensor has a linear response over a very wide primary current range, far exceeding the typical CT range.

Current sensor

Current measurement in KEVCY 24 RE1 sensors is based on the Rogowski coil principle. A Rogowski coil is a toroidal coil without an iron core placed around the primary conductor in the same way as the secondary winding in a current transformer.

Voltage sensor

Voltage measurement in KEVCY 24 RE1 sensors is based on the capacitive divider principle.

Sensor application

KEVCY 24 RE1 are compact and very small bushing type sensors designed to be used in SF₆ gas insulated switchgear type SafeRing and SafePlus. The external cone type of the sensor is designed according to the standard EN 50181, Interface C (400 series 630 A, M16 bolt) and therefore enables connection of all compatible cable plugs.

Secondary cables

The sensor is equipped with two cables:

- Cable for coupling electrode with BNC connector
- Current and voltage signal cable with RJ-45 connector for connection with the IED

The cable connector for connection with the IED is type RJ-45. The sensor accuracy classes are verified up to the RJ-45 connector, i.e. considering also its secondary cable.

This cable is intended to be connected directly to the IED, and subsequently neither burden calculation nor secondary wiring is needed. Every sensor is therefore accuracy tested when equipped with its own cable and connector. Standard cable length for connection with an IED is 2.2 meters. Standard cable length for connection with a coupling electrode is 0.45 meters.



Technical data, general

Rated primary current of application	up to 630 A
Rated primary voltage of application	up to 24 kV
Highest voltage for equipment, U _m	24 kV
Rated power frequency withstand voltage	50 kV
Rated lightning impulse withstand voltage	125 kV

Technical data, voltage sensor

Technical data, voltage sensor	Value
Rated primary voltage, U _{pr}	22/√3 kV
Maximum rated primary voltage, U _{primax}	22/√3 kV
Rated frequency, f _n	50/60 Hz
Voltage accuracy class	0.5/3P
Rated burden, R _{br}	10 MOhm
Rated transformation ratio, K _n	10 000 : 1
Rated voltage factor, K _v	1.9/8h

Technical data, current sensor

Rated primary current, I _{pr}	80 A
Rated transformation ratio, K _{ra}	80 A / 150 mV at 50 Hz 80 A / 180 mV at 60 Hz
Rated secondary output, U _{sr}	3mV/Hz i.e 150 mV at 50 Hz or 180 mV at 60 Hz
Rated continuous thermal current, I _{cth}	630 A
Rated short-time thermal current, I _{th}	25 kA / 3 s
Rated dynamic current, I _{dyn}	63 kA
Rated frequency, f _r	50/60 Hz
Rated extended primary current factor, K _{pcr}	7.875
Current accuracy class	0.5/5P100
Accuracy limit factor, K _{alf}	100
Rated burden, R _{br}	10 MOhm

Cables

Current and voltage sensing:	
Length	2.2 m
Connector	RJ-45 (CAT-6)
Coupling electrode:	
Length	0.45 m
Connector	BNC

11 Sensors

KECA 80 C85 Indoor current sensor

Electronic Instrument Transformers (sensors) offer an alternative way of making the current measurement needed for the protection and monitoring of medium voltage power system. Sensors based on alternative principles have been introduced as successors to conventional instrument transformers in order to significantly reduce size, increase safety and to provide greater rating standardization and a wider functionality range. These well known principles can only be fully utilized in combination with versatile electronic relays.

Sensor characteristics

KECA 80 C85 sensors are able to reach measuring class 0.5 for continuous measurement from 5% of the rated primary current (I_{pr}) up to the rated continuous thermal current (I_{cth}). This is beyond 120% of I_{pr} that is common for conventional CTs.

For dynamic current measurement (protection purposes), ABB sensors KECA 80 C85 fulfill requirements of protection class 5P up to an impressive value reaching the rated short-time thermal current I_{th} . That provides the possibility to designate the corresponding accuracy class as 5P630, proving excellent linearity and accuracy measurements.

Sensor applications

KECA 80 C85 sensors are intended for use in current measurement in low voltage or medium voltage switchgear. In medium voltage switchgear, the current sensor shall be installed over a bushing insulator, insulated cable, insulated and shielded cable connectors or any other type of insulated conductor. The current sensor is equipped with a clamping system which provides easy and fast installation and therefore makes the sensor suitable for retrofit purposes.

Secondary cables

The sensor is equipped with a cable for connection with an IED using cable connector type RJ-45. The sensor accuracy classes are verified up to the RJ-45 connector, i.e. considering also its secondary cable. These cables are intended to be connected directly to the IED and subsequently neither burden calculation nor secondary wiring is needed. Every sensor is therefore accuracy tested when equipped with its own cable and connector.

The design of the sensor is optimized to be easily assembled on the shielded cable connectors used with bushings designed according to the standard EN 50181, Interface C.



Parameters for application

Rated primary current of application	up to 2500 A
--------------------------------------	--------------

Sensor parameters

Highest voltage for equipment, U_m	0.72 kV
Rated power frequency withstand voltage	3 kV
Rated primary current, I_{pr}	80 A
Rated continuous thermal current I_{cth}	2500 A
Rated transformation ratio, K_{ra}	80A / 150 mV at 50 Hz 180 mV at 60 Hz
Rated short-time thermal current, I_{th}	50 kA/3 s
Rated dynamic current, I_{dyn}	125 kA
Rated frequency, f_r	50/60 Hz
Rated extend primary current factor, K_{pcr}	31.25
Accuracy limit factor, K_{alf}	630
Accuracy class	0.5/5P630
Rated burden, R_{br}	10 MOhm
Length of cable	2.2; 3.4; 3.6 m
Connector	RJ-45 (CAT-6)
Weight	0.25 kg

Correction factors

The amplitude and phase error of a current sensor is, in practice, constant and independent of the primary current. Due to this fact it is an inherent and constant property of each sensor and it is not considered to be an unpredictable and influenced error. Hence, it can be easily corrected in the IED by using appropriate correction factors, stated separately for every sensor.

KECA 80 D85 Indoor current sensor (split core type)

Electronic Instrument Transformers (sensors) offer an alternative way of making the current measurement needed for the protection and monitoring of medium voltage power system. Sensors based on alternative principles have been introduced as successors to conventional instrument transformers in order to significantly reduce size, increase safety and to provide greater rating standardization and a wider functionality range. These well known principles can only be fully utilized in combination with versatile electronic relays.

Sensor characteristics

KECA 80 C85 sensors are able to reach measuring class 0.5 for continuous measurement from 5% of the rated primary current (I_{pr}) up to the rated continuous thermal current (I_{cth}). This is beyond 120% of I_{pr} that is common for conventional CTs.

For dynamic current measurement (protection purposes), ABB KECA 80 C85 sensors fulfill requirements of protection class 5P up to an impressive value reaching the rated short-time thermal current I_{th} . That provides the possibility to designate the corresponding accuracy class as 5P630, proving excellent linearity and accuracy measurements.

Sensor applications

KECA 80 D85 sensors are intended for use in current measurement in medium voltage air and gas insulated switchgear. The current sensor is split core type equipped with a clamping system which provides easy and fast installation and therefore makes the sensor suitable for retrofit purposes. The current sensor shall be installed over a bushing insulator, insulated cable, insulated & shielded cable connectors or any other type of insulated conductor.

Secondary cables

The sensor is equipped with a cable for connection with an IED using cable connector type RJ-45. The sensor accuracy classes are verified up to the RJ-45 connector, i.e. considering also its secondary cable. These cables are intended to be connected directly to the IED and subsequently neither burden calculation nor secondary wiring is needed. Every sensor is therefore accuracy tested when equipped with its own cable and connector.



Parameters for application	
Highest voltage for equipment, U_m	0.72 kV
Rated power frequency withstand voltage	3 kV
Rated primary current, I_{pr}	80 A
Rated continuous thermal current, I_{cth}	4000 A
Rated transformation ratio, K_{ra}	80A / 150 mV at 50 Hz 180 mV at 60 Hz
Rated short-time thermal current, I_{th}	50 kA/3 s
Rated dynamic current, I_{dyn}	125 kA
Rated frequency, f_r	50/60 Hz
Rated extend primary current factor, K_{pcr}	50
Accuracy limit factor, K_{aif}	630
Accuracy class	0.5/5P630
Rated burden, R_{br}	10 MOhm
Length of cable	2.2; 5 m
Connector	RJ-45 (CAT-6)
Weight	0.25 kg

Correction factors

The amplitude and phase error of a current sensor is, in practice, constant and independent of the primary current. Due to this fact it is an inherent and constant property of each sensor and it is not considered as an unpredictable and influenced error. Hence, it can be easily corrected in the IED by using appropriate correction factors, stated separately for every sensor.

KEVA 24 C Indoor voltage sensor

KEVA 24 voltage sensors are intended for use in voltage measurement in gas insulated medium voltage switchgear. The voltage sensors are designed to easily replace the insulating plugs originally used in the cable T-connectors. Due to their compact size and optimized design, sensors can be used for retrofit purposes as well as in new installations.

Correction factors

The amplitude and phase error of a voltage sensor is, in practice, constant and independent of the primary voltage. Due to this fact, it is an inherent and constant property of each sensor and is not considered to be an unpredictable and influenced error. Hence, it can be easily corrected in the IED by using appropriate correction factors, stated separately for every sensor.

Values of the correction factors for the amplitude and phase error of a current sensor are mentioned on the label and should be uploaded into the IED without any modification before the sensors are put into operation. Please refer to the relevant instructions and manuals for more information.

Parameters for application	
Rated primary voltage of application	up to 24 kV
Sensor parameters	
Rated primary voltage, U_{pn}	$22/\sqrt{3}$
Highest voltage for equipment, U_m	24 kV
Rated power frequency withstand voltage	50 kV
Rated lightning impulse withstand voltage	125 kV
Rated continuous thermal current I_{cth}	2500 A
Rated transformation ratio, K_{ra} for voltage measurement	10000 : 1
Voltage accuracy class	0.5/3P
Length of cable	2.2 m



Sensor variants and use in cable T-connectors

Sensor type designation	Cable T-connectors		
	Manufacturer	Type	Interface
KEVA 24 C10	Nexans-Euromold	400 TB/G	M16
		440 TB/G	
		K400 TB/G	
		K440 TB/G	
KEVA 24 C21	Kabeldon	400PB-xSA	M16
		CSE-A 12630	
		CSEP-A 12630	
		CSE-A 24630	
		CSEP-A 24630	
KEVA 24 C22	NKT	SOC 630 - 1/2	M12
		CB 12-630	
		CC 12-630	
	Raychem	CB 24-630	
		CC 24-630	
		RSTI L56xx	
KEVA 24 C23	Raychem	RSTI-CC L56xx	M16
		RSTI 58xx/39xx	
	RSTI CC 58xx/39xx		
	RSTI LCxx/LAxx (older)		
	NKT	CB 12-630	
KEVA 24 C24	Nexans-Euromold	CC 12-630	M16
		CB 24-630	
		CC 24-630	
		430 TB - 630	
		K430 TB - 630	
300 PB - 630			
		K300 PB - 630	

12 Mechanisms

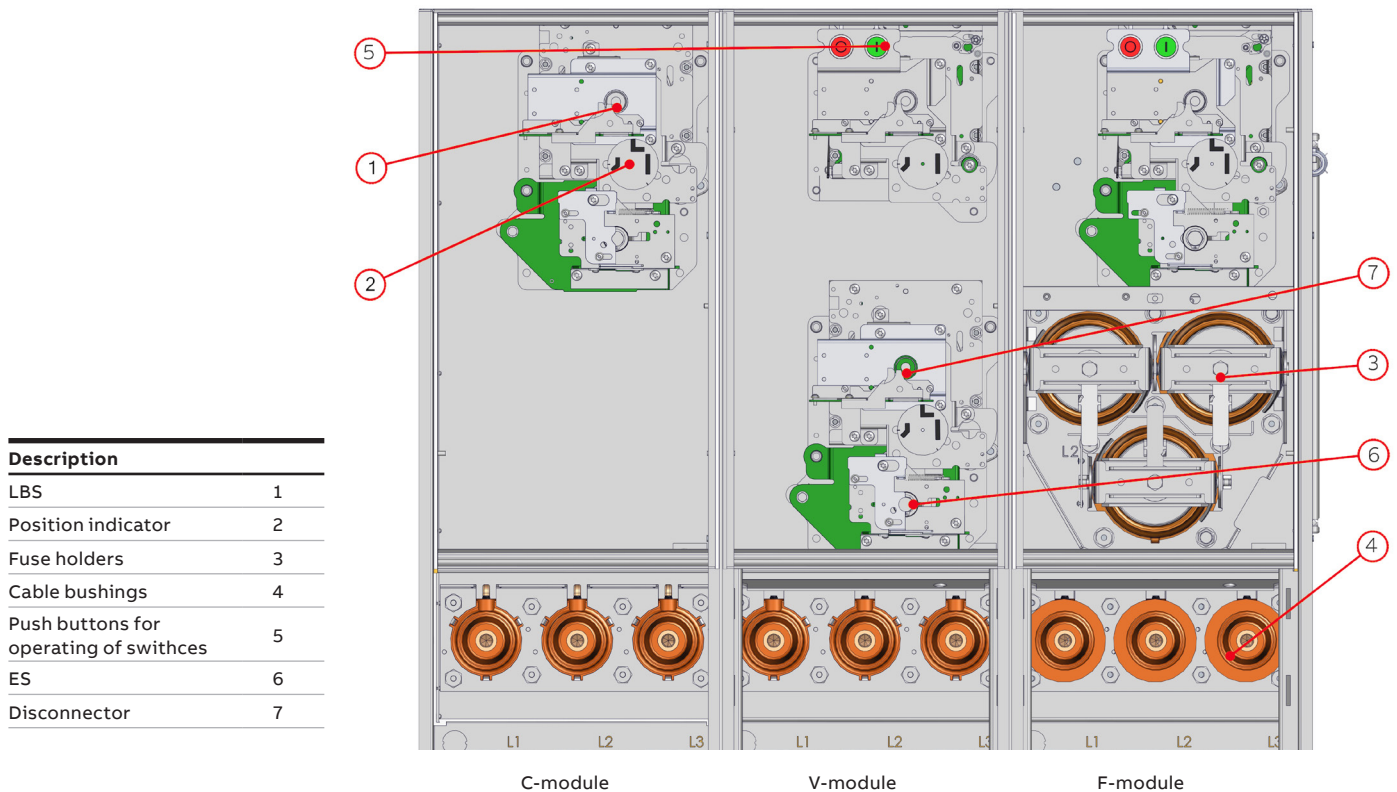

All operating mechanisms are situated outside the SF₆ gas tank behind the front covers with degree of protection of IP2X.

This allows for easy access to all operating mechanisms if retrofit or service should be required. The speed of operation of these mechanisms is independent of the operator.

To prevent access to the cable compartment before the earthing switch is in closed position, all mechanisms can as an option be supplied with mechanical interlocks. These make it impossible to remove the cable compartment covers with the earthing switch in open position. It will then also be impossible to operate the load break/disconnector switch to open position before the cable compartment cover is mounted properly.

Each mechanism is equipped with a padlocking device. When adding a padlock to this device, access to operate the mechanism will be impossible. This device has three holes; the diameter of suitable padlocks is 4 - 8 mm.

All operating mechanisms are equipped with position indicators for all switches. In order to achieve true indication, indicators are directly connected to the operating shafts of the switches inside the SF₆ gas tank. Please see shafts shown with green color on next page.

The operating handle has an anti-reflex system which prevents an immediate re-operation of the switch.

Cable switch module and busbar sectionalizer with load break switch

The mechanism (3PKE) has two operating shafts; the upper one for the load break switch and the lower one for the earthing switch.

Both shafts are single spring operated and operate one common shaft which is directly connected to the three position switch (CFE-C) inside the SF₆ gas tank. When both load break switch and earthing switch are in open position, the switch satisfies the specifications of disconnecter.

Due to the mechanical interlock between the upper and lower operating shaft, it is impossible to operate the load break switch when the earthing switch is in closed position or to operate the earthing switch when the load break switch is in closed position.

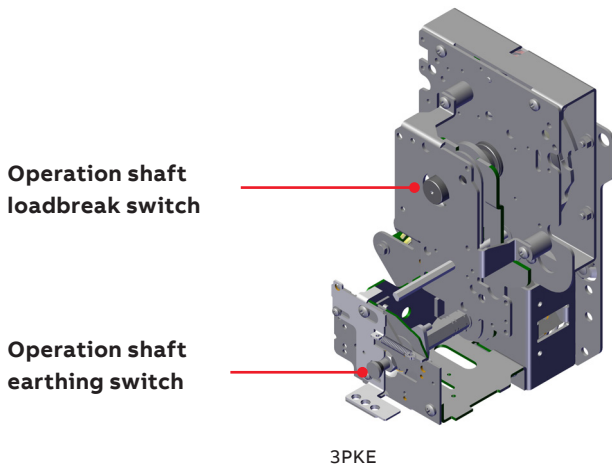

Switch-fuse module

The mechanism (3PAE) has two operating shafts; the upper one for the load break switch and the lower one for the earthing switch.

The upper shaft operates two springs: one for closing and one for opening. Both springs are charged in one operation. By means of mechanical push buttons it is then possible to close and open the load break switch.

The opening spring is always charged when the load break switch is in closed position and will be ready to open the load break switch immediately if one of the HV-fuse-links blows. The blown fuse-link(s) has/have to be replaced before the operator will be able to close the load break switch again. According to IEC 60282-1, all three fuse-links should be replaced, even if only one or two have operated.

The lower shaft is single spring operated. Both operating shafts operate one common shaft which is directly connected to the three position switch (CFE-F) inside the SF₆ gas tank. Due to the mechanical interlock between the upper and lower operating shaft, it is impossible to operate the load break switch when the earthing switch is in closed position or to operate the earthing switch when the load break switch is in closed position.

It will also be impossible to access the fuse compartment before the earthing switch is in closed position.

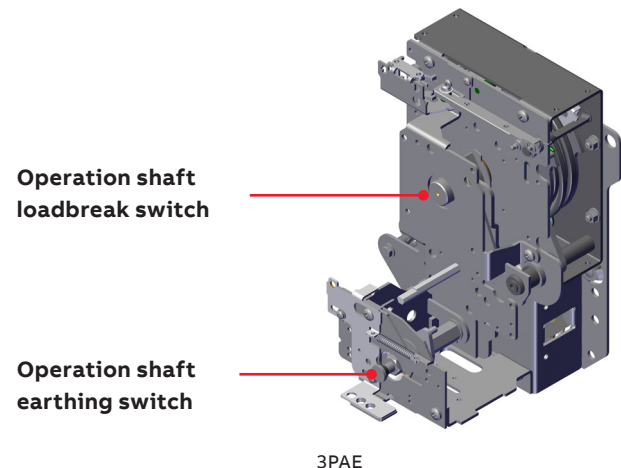

Vacuum circuit breaker and busbar sectionalizer with circuit breaker

These two modules have two mechanisms; the upper one (2PA) with one operating shaft is for the circuit-breaker and the lower one (3PKE) with two operating shafts is for the disconnecter and earthing switch.

The upper mechanism has two operating springs; one for closing and one for opening. Both springs are charged in one operation. By means of mechanical push buttons it is then possible to close and open the circuit-breaker.

The opening spring is always charged when the circuit-breaker is in closed position and will be ready to open immediately if the protection relay gives a trip signal.

However, a quick reclosing is not possible. If the mechanism is equipped with a motor operation, a reclosing will take approximately 10 seconds. The lower mechanism is of type 3PKE and therefore identical to the one described above for the cable switch module.

There is a mechanical interlock between these two mechanisms which prevents operating of the disconnecter and earthing switch when the circuit-breaker is in closed position. When the earthing switch is in closed position it will be impossible to operate the disconnecter, but the circuit breaker can be closed for testing purpose.

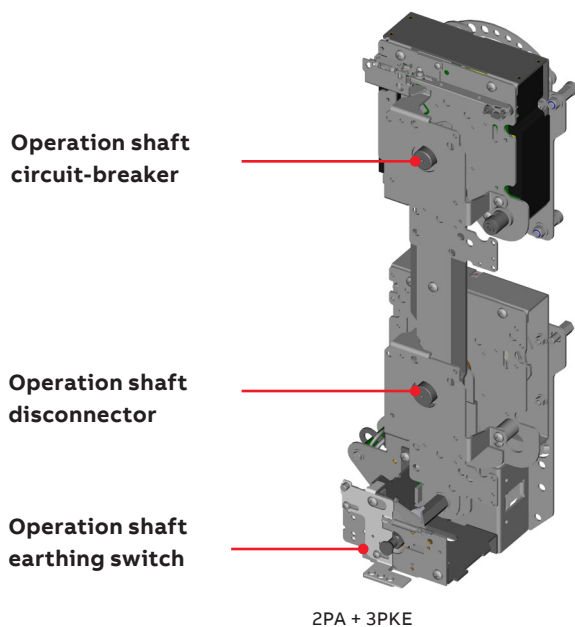

High duty vacuum circuit-breaker V25/V20

This module has two mechanisms; the upper one (EL2/EL2S) is for the circuit-breaker and the lower one (3PKE) with two operating shafts is for the disconnecter and earthing switch. The vacuum circuit-breaker has the possibility of rapid auto-reclosing duty.

By means of mechanical push buttons it is possible to close and open the circuit-breaker. The opening spring is always charged when the circuit-breaker is in closed position and will be ready to open immediately if the protection relay gives a trip signal. If the mechanism is recharged after closing it is possible to perform open - close - open sequence.

The lower mechanism is of type 3PKE and therefore identical to the one described above for the cable switch module.

There is a mechanical interlock between these two mechanisms which prevents operating of the disconnecter and earthing switch when the circuit-breaker is in closed position. When the earthing switch is in closed position it will be impossible to operate the disconnecter, but the circuit-breaker can be closed for testing purpose.

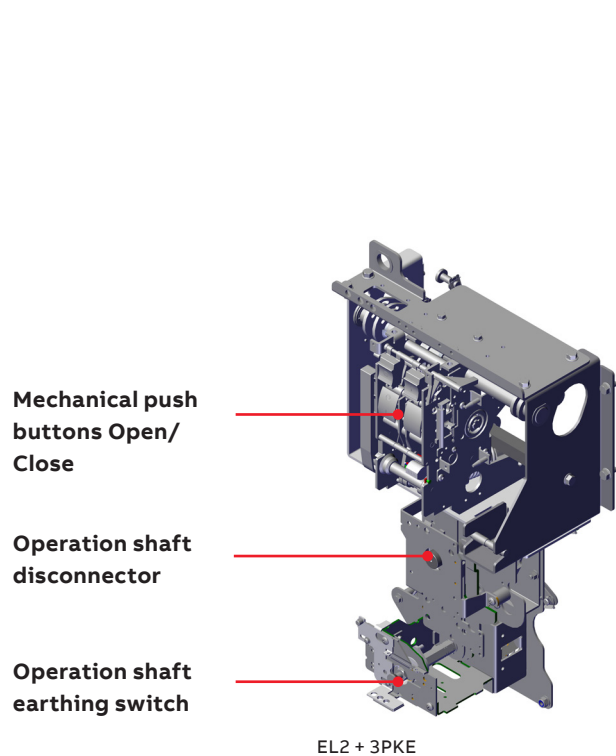

13 Cable bushings

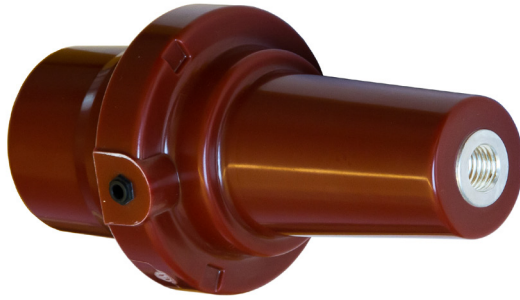

The connection of the HV-cables is made by cable bushings. The bushings are made of cast resin epoxy with moulded-in conductors. In addition a screen is moulded in, for controlling the electrical field. The screen is also used as the main capacitor supplying the voltage indicating systems.

Up-to-date production facilities and highly advanced robots and test equipment ensure the high quality required for each single device.

A very high number of units have been installed worldwide in distribution networks, power stations and industrial complexes.

Used together with fully screened connectors, these bushings present an ideal solution for areas with humidity or condensation problems. The bushings are designed according to CENELEC EN 50181, EDF HN 52-S-61 and IEC 60137.

There are 3 different types of cable bushings available:

- Interface A (200 series with plug-in contact, $I_n=200A$)
- Interface C (400 series with M16 bolted contact, $I_n=630A$)
- Interface C (400 series with M16 bolted contact) and integrated voltage and current sensors ($I_n=630A$)

—
01 Interface A
—
02 Interface C

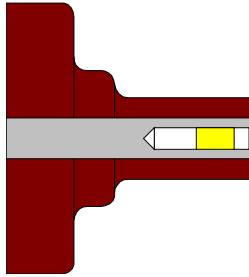

—
01

The following cable bushings are available as standard:

- Interface A with plug
- 200 series, $I_n = 200\text{ A}$
- Standard on F and V modules ($I_n = 200\text{ A}$)
- The yellow area indicates the silver coated contact spring
- Cable cross-section: See tables 16.1.1 and 16.2.1

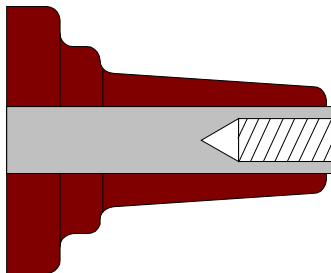

—
02

- Interface C with M16 x 2 metric threads
- C1, $I_n = 630\text{ A}$
- C2, $I_n = 1250\text{ A}$
- Standard on C, V ($I_n=630\text{A}$), D and De modules; and for top extension
- Cable cross-section: See tables 16.1.2 and 16.2.2

Cable bushings Interface B are also available on request.

The installation instructions from the cable termination manufacturer must be followed. Be sure to lubricate the bushings thoroughly with the silicone supplied.

Where cables are not connected, the earthing switch must be locked in closed position or the bushings must be fitted with dead end receptacles before the unit is energized.

14 Cable termination

All bushings are situated at the same height from the floor and are protected by a cable compartment cover. The three drawings below show typical arrangements with cable connectors for single and double cables.

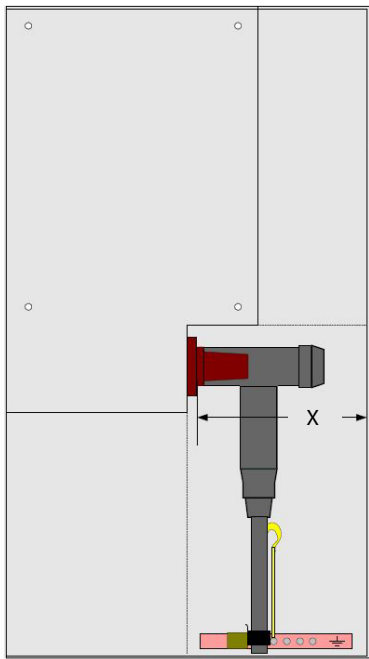

Standard cable cover with single cable

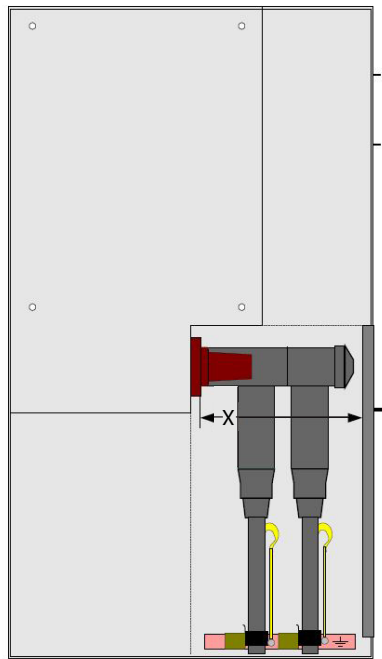

Arc proof cable cover with double cable

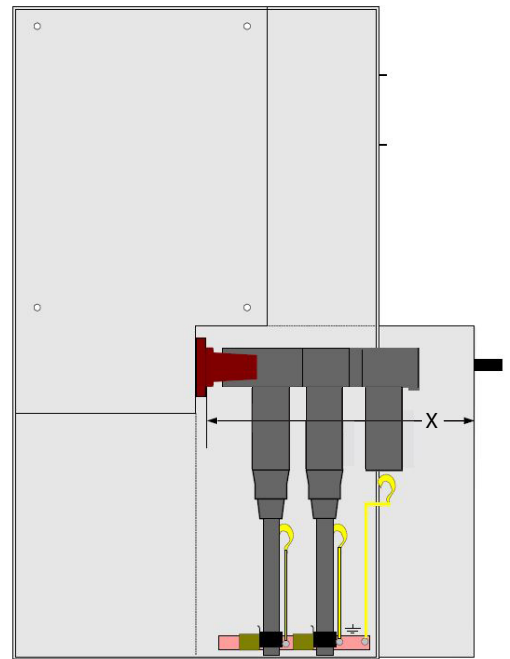

Extended cable cover with double cable and surge arrester

The table below shows the net distance X in millimeters from cable bushing to the inner part of cable compartment cover.

Cable compartment type	Interface A (200 series plug-in)	Interface C (400 series bolted)
Standard cable cover	400	360
With window	392	353
Arc proof cable cover with/without window	377	337
Expanded cable cover	595	555

The following manufacturers of cable terminations are recommended:

- 3M
- Euromold/Elastimold
- NKT cables
- Prysmian
- Südkabel
- Tyco Electronics/Raychem



CSE-A 12250
CSE-A 24250

CSE-A 12400
CSE-A 24400

CSE-A 12630
CSE-A 24630

Screened separable cable connectors

CSE-A 12-24 kV, 250 A, 400 A, 630 A

Application area

Pre-moulded, screened, separable connectors for XLPE insulated 1- or 3-core cables with aluminum or copper conductors for 12–42 kV. Can be installed both indoors and outdoors.

Fits standard bushings of outer cone type according to EN 50181. Connectors with rated current:

- 250 A: interface type A with plug-in Ø 7.9 mm
- 630 A: interface type C with bolt M16

Standard

Meets the requirements of:

- CENELEC, HD 629.1 S2

Design

CSE-A is premoulded and manufactured in rubber with three layers, a conductive inner layer, an insulation layer and a conductive outer layer, that are vulcanized together for the best possible interface between the layers.

The cable connectors include both a capacitive test point with protection and an integrated earthing wire.

Delivered in 3-phase kits, complete with cable lugs, bolt connection and stress grading adapter, designed to ensure a reliable installation.

Note:

For 3-core cable with common Cu-screen wires, a screen separation kit must be used.

Designation	XLPE/EPR Ø mm ²	Conductor cross section mm ²	Rated current	Bushing type	Weight kg/unit
Elbow cable connector with capacitive test point, 12kV					
CSE-A 12250-01	10 - 12	10 - 16	250 A	Interface type A with plug-in Ø 7.9 mm	2.2
CSE-A 12250-02	13 - 22	25 - 95	250 A	Interface type A with plug-in Ø 7.9 mm	2.2
CSE-A 12400-01	13 - 20	25 - 70	400 A	Interface type B with plug-in Ø 14 mm	6.1
CSE-A 12400-02	18.5 - 30.5	95 - 300	400 A	Interface type B with plug-in Ø 14 mm	6.6
CSE-A 12630-01	13 - 20	25 - 70	630 A	Interface type C with bolt M16	5.1
CSE-A 12630-02	18.5 - 30.5	95 - 300	630 A	Interface type C with bolt M16	5.5
CSE-A 12630-03	30.5 - 45.0	400 - 630	630 A	Interface type C with bolt M16	7.7
Elbow cable connector with capacitive test point, 24kV					
CSE-A 24250-01	13 - 22	10 - 16	250 A	Interface type A with plug-in Ø 7.9 mm	2.2
CSE-A 24250-02	17.0 - 25.5	25 - 95	250 A	Interface type A with plug-in Ø 7.9 mm	2.2
CSE-A 24400-01	17 - 24	25 - 70	400 A	Interface type B with plug-in Ø 14 mm	6.1
CSE-A 24400-02	22.5 - 35.0	95 - 300	400 A	Interface type B with plug-in Ø 14 mm	6.6
CSE-A 24630-01	17 - 24	25 - 70	630 A	Interface type C with bolt M16	5.1
CSE-A 24630-02	22.5 - 35.0	95 - 300	630 A	Interface type C with bolt M16	5.5
CSE-A 24630-03	30.5 - 45.0	400 - 630	630 A	Interface type C with bolt M16	7.7

14.1 Cable termination 12 kV

Table 14.1.1

12 kV: Separable connectors interface A with earthing shield, $I_n = 250$ A

Manufacturer	Designation	Conductor [mm²]	XLPE / EPR Ø [mm]
3M	93-EE 605-2	25-95	17.2-25.0
Euromold	K200LR-12	25-95	18.4-26.4
NKT cables	CSE-A 12250-01	10-16	10.0-12.0
NKT cables	CSE-A 12250-02	25-95	13.0-21.0
Prysmian	FMCE-250	16-95	10.0-21.3
Südkabel	SEW 12	25-150	12.2-25.0
Tyco Electronics	RSES	16-150	12.7-28.5

For dynamic and thermal short-circuit currents, please compare the values expected in your network with the rated values of the connector from the different suppliers

Table 14.1.2

12 kV: Separable connectors interface C, I _r = 630 A						Cable compartment with							
						Single cable + surge arrester				Dual cables			
Manufacturer	Designation	Conductor [mm ²]	XLPE / EPR Ø [mm]	Additional equipment for dual cable arrangement	Surge Arrester with	Standard Distance X = 360 mm	With window Distance X = 353 mm	Arc proof Distance X = 337 mm	Deep Distance X = 555 mm	Standard Distance X = 360 mm	With window Distance X = 353 mm	Arc proof Distance X = 337 mm	Deep Distance X = 555 mm
3M	93-EE 705-6	50-400	15.0-34.6	KU 21	MUT 23	•	•	•	•	•	•	•	•
Euromold	480TB/G	16-300	12.0-37.5	800 PB/G	800SA	•	•	•	•	•	•	•	•
Euromold	484TB/G	50-630	16.0-56.0	800PG/G	800SA	•	•	•	•	•	•	•	•
NKT cables	CSE-A 12, 630	25-630	13.0-45.0	CSEP-A 12	CSAP-12	•	•	•	•	•	•	•	•
NKT cables	CB 24-630	25-300	12.7-34.6	CC 24-630	CSA M16	•	•	•	•	•	•	•	•
Prysmian	MSCEA-630	25-300	13.0-33.0			•							
Südkabel	SET 12	50-300	15.0-32.6	SEHDK 13.1		•	•	•	•	•	•	•	•
Südkabel	SEHDT 13	185-500	22.0-40.6		MUT 23	•	•	•	•				
Tyco Electronics	RSTI-58	25-300	12.7-34.6	RSTI-CC-58	RSTI-58SA	•	•	•	•	•	•	•	•
Tyco Electronics	RICS	25-300	17.5-42.0		RDA	•	•	•	•				

Separable connectors without earthing shield are not recommended.
 For dynamic and thermal short-circuit currents, please compare the values expected in your network with the rated values of the connector from the different suppliers.

14.2 Cable termination 24 kV

Table 14.2.1

24 kV: Separable connectors interface A with earthing shield, $I_n = 250$ A

Manufacturer	Designation	Conductor [mm²]	XLPE / EPR Ø [mm]
3M	93-EE 605-2	25-150	17.2-28.5
Euromold	K200LR-16	25-95	17.5-25.0
NKT cables	CSE-A 24250-01	10-16	13.0-22.0
NKT cables	CSE-A 24250-02	25-95	17.0-25.5
Prysmian	FMCE-250	35-120	18.6-26.0
Südkabel	SEW 24	25-95	17.3-25.0
Tyco Electronics	RSES	16-150	12.7-28.5

Separable connectors without earthing shield are not recommended.

For dynamic and thermal short-circuit currents, please compare the values expected in your network with the rated values of the connector from the different suppliers.

Table 14.2.2

24 kV: Separable connectors interface C with earthing shield, $I_n = 630$ A						Cable compartment with							
						Single cable + surge arrester				Dual cables			
Manufacturer	Designation	Conductor [mm ²]	XLPE / EPR Ø [mm]	Additional equipment for dual cable arrangement	Surge Arrester with	Standard Distance X = 360 mm	With window Distance X = 353 mm	Arc proof Distance X = 337 mm	Deep Distance X = 555 mm	StandXrd Distance X = 360 mm	With window Distance X = 353 mm	Arc proof Distance X = 337 mm	Deep Distance X = 555 mm
3M	93-EE 705-6	50-240	15.0-32.6	KU 23.2	MUT 23	•	•	•	•				•
Euromold	K480TB/G	25-300	12.0-37.5	K800PB/G	800SA	•	•	•	•	•	•	•	•
Euromold	K484TB/G	35-630	16.0-56.0	K800PB/G	800SA	•	•	•	•	•	•	•	•
NKT cables	CSE-A 24, 630	25-630	17.0-45.0	CSEP-A 24, 630	CSAP-A 24	•	•		•	•	•		•
NKT cables	CB24-630	25-300	12.7-34.6	CC 24-630	CSA M16	•	•	•	•	•	•	•	•
Prysmian	MSCEA-630	25-300	16.1-35.3			•							
Südkabel	SET 24	25-240	15.0-32.6	SEHDK 23.1		•	•	•	•				•
Südkabel	SEHDT 23	185-630	26.3-45.6		MUT 23	•	•	•	•				
Tyco Electronics	RSTI-58	25-300	12.7-34.6	RSTI-CC-58	RSTI-58SA	•	•	•	•	•	•	•	•
Tyco Electronics	RICS	25-300	21.5-42.0		RDA	•	•	•	•				

Separable connectors without earthing shield are not recommended.

15 Cable test bushings

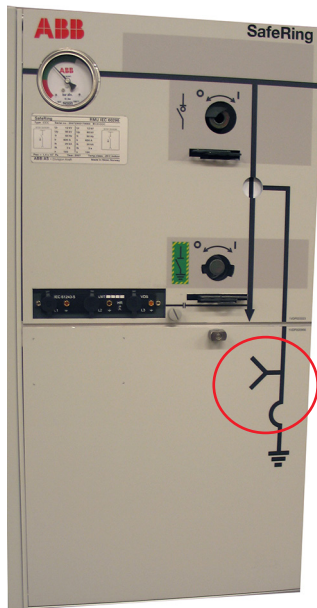

As an option, both C- and De-modules can be equipped with cable test bushings situated behind the lower front cover. This cover can be interlocked against the earthing switch to avoid access to the cable test compartment before the earthing switch is in closed position.

When these bushings are mounted, cable insulation tests can easily be done according to the following procedure:

Recommended procedure for testing:

1. Close the earthing switch after having checked the voltage indicators
2. Open compartment cover
3. Install the injection device onto the access terminals
4. Open the removable earthing bridge
5. Perform cable testing
6. Re-install the earthing bridge
7. Remove the injection device
8. Close compartment cover
9. Open the earthing switch

If the switchgear is not equipped with cable test bushings, cable testing is possible directly at the cable connectors if they are designed for this purpose. Please follow the supplier's instruction. For interlocking on the cable test cover, see interlock table for C-module, chapter 7.2.2.

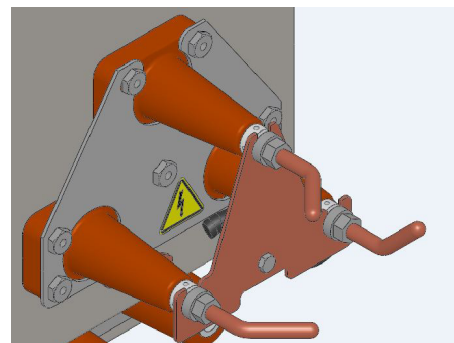
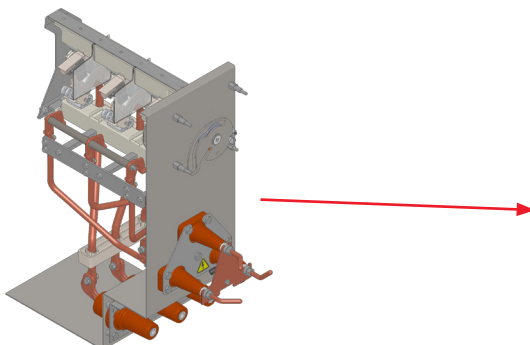

16 Extension of switchgear

16.1 External busbars on top

01 SafePlus prepared for future extension on right hand side.

02 Fully modular SafePlus with external busbar cover.

03 SafePlus with one incomer (C-module), one Metering module (M-module) and three fused T-offs (F-modules), prepared for future extension.

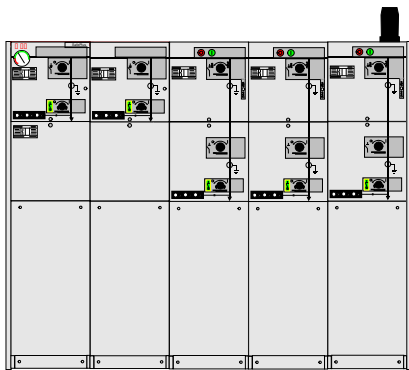

01

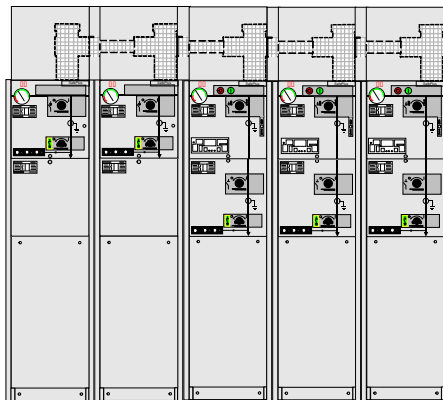

02

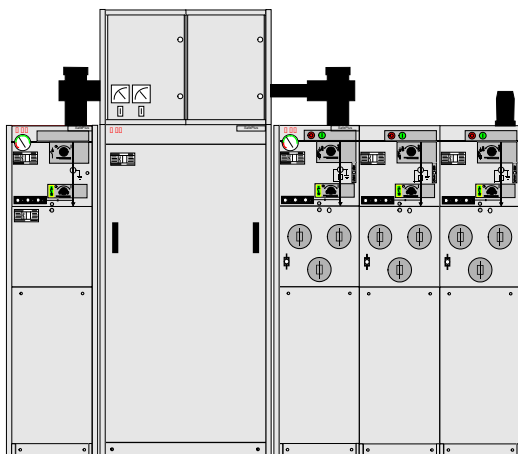

03

On the top of all SafeRing/SafePlus switchgears it is possible as an option to have bushings for connection of external busbars on the left and/or right side.

For a SafePlus switchgear consisting of only one module, only one set of bushings on the top is used.

When bushings are mounted on the top, you will have these possibilities:

- When adding a dead end receptacle to each of these bushings, SafeRing/ SafePlus will be prepared for future busbar extension.
- With an external busbar kit, it is possible to connect two or more sections

Since a 5-way switchgear is the maximum size within one common SF₆ gas tank, the busbar kit allows a configuration with more than 5 modules.

The installation of the external busbars has to be done on site. See manual 1VDD006006 for installation instructions.

The complete extension kit and the dead end receptacles are fully screened, earthed and insulated with EPDM rubber. This makes a safe and reliable switchgear extension. In addition, protection covers are available as an option.

SafePlus switchgear can also be configured as fully modular. This results in a 1250 A busbar rating.

The busbars between the modules and the end adapters used on the left and right side are identical to the parts used in the previous example. For the three modules in the middle, a special cross adapter is used.

The length of the external busbars is dependent on the type of modules to be connected.

Connection by external busbars is available for all modules except the Mt-module.

16.2 Side extension

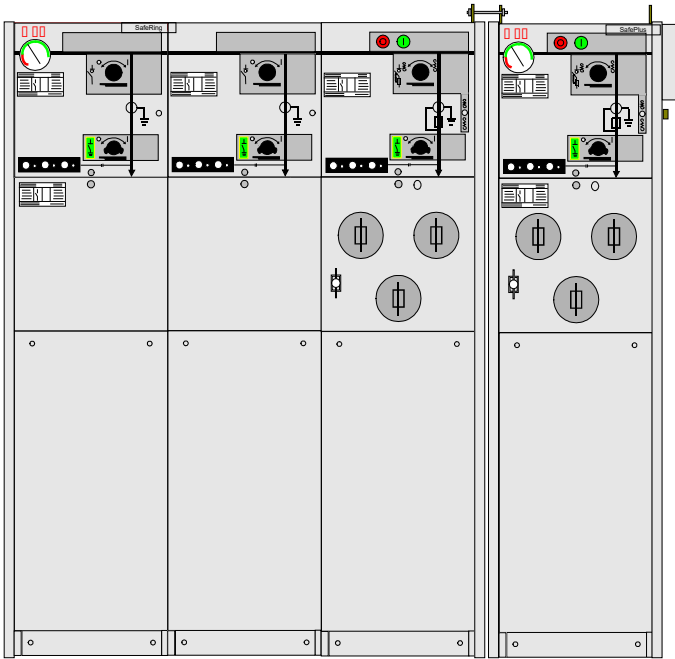

It is possible to have optional bushings on the left or right side of SafeRing or SafePlus C- or F-modules for side connection of external busbars. The rated current of the side connection is limited to 400A.

For a 1-way SafePlus C- or F-module, one or two sets of bushings can be installed. This is also applicable for a 2-way unit.

When bushings are mounted on the side, you will have these possibilities:

- When adding a dead end receptacle to each of these bushings, SafeRing / SafePlus will be prepared for future busbar extension
- With a specially designed connection kit, it will be possible to connect two or more sections

Since a 5-way switchgear is the maximum size within one common SF₆ gas tank, the busbar kit allows a configuration with more than 5 modules. The second switchgear can consist of maximum 2 modules.

The installation of the external busbars has to be done on site. See manual 1VDD006106 for installation instructions.

SafePlus switchgear can also be configured as fully modular. The busbars between the modules and the end adapters used on the leftmost and rightmost module are identical to the parts used in the previous example.

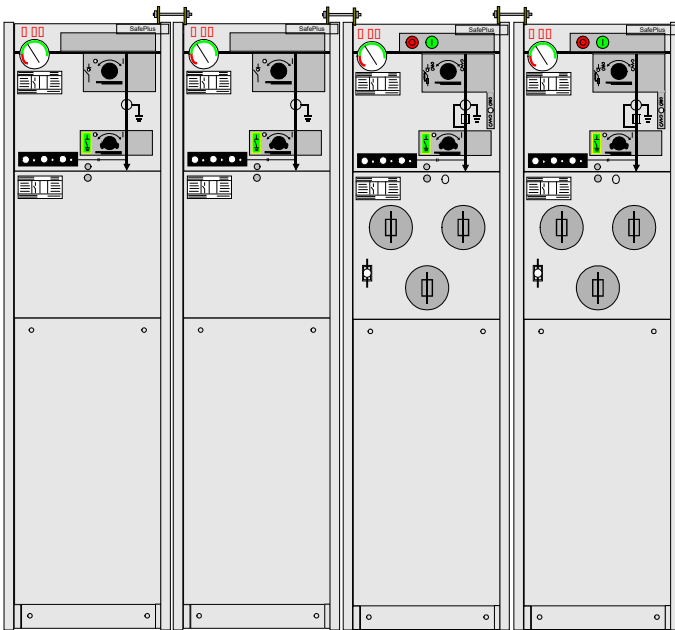

17 Base frame

—
01 Base frame 450 mm
with earth-fault
transformer and
extra set of current
transformers

—
02 Base frame 290 mm
with an extra set of
current transformers

—
03 Base frame 290 mm
with earth-fault
transformer

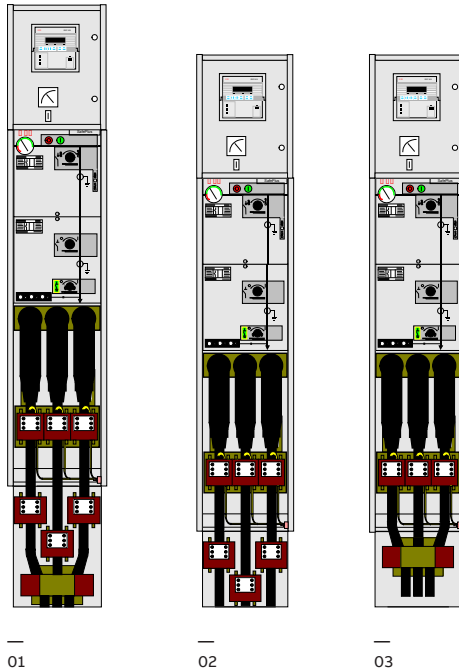

01

02

03

When SafeRing or SafePlus is placed directly on a floor, the height from the floor to the centre of the cable bushings is 595 millimeters. If there is no cable trench this height might not be sufficient for proper installation of cables. It is then possible to place the switchgear on an additional base frame.

This base frame is available in two different heights; 290 and 450 millimeter.

Inside the standard cable compartment for the vacuum circuit-breaker there will be enough space for three current transformers for the protection relay.

If an earth-fault transformer or an extra set of current transformers is required, an additional base frame is necessary. Please see examples on the left hand side.

The base frame has openings for cable entrance from the bottom and from both sides. It is delivered as a kit and has to be assembled on site.



Front view

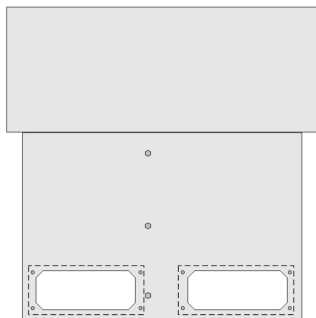

Side view

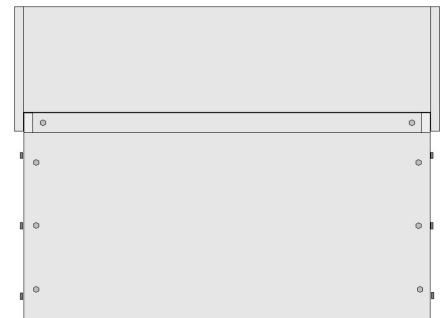

Rear view

18 Low voltage compartment / Top entry box

—
01 Low voltage compartment with REF615 relay

—
02 Top entry box with A-meter and selector switch

—
03 Side view top entry box

—
04 Top entry box seen from above when front / top covers have been removed

Low voltage compartment

All SafePlus switchgears can be supplied with an optional low voltage compartment. This compartment may be equipped with protection relays, meters, position switches, terminal blocks, etc.

The compartment is fixed to the side covers of the SF₆ gas tank and must cover the total width of the switchgear. Each module has a separate hinged door. There are no partition walls between the modules.

The low voltage compartment has the possibility of external cable entry from either left- or right-hand side.

A locking system for the doors are available on request.

Different heights for the low voltage compartment are available: 300, 470 and 700 mm. For V-module 12kV/25kA and 24kV/20kA, 100 mm has to be added to the height of the low voltage compartment.

Top entry box

If motor operation, coils, auxiliary switches, self-powered protection relay, etc. are mounted on a SafeRing or SafePlus module, the terminal blocks and the wiring are located behind the front covers.

An additional top entry box can be mounted on the top of all SafeRing and SafePlus switchgears. Since the top entry box is fixed to the side covers of the SF₆ gas tank, the total width of the switchgear must be covered.

The top entry box allows entrance of the customer's low voltage wiring from the rear side, left-hand side and right-hand side.

Furthermore, the top entry box gives the opportunity to install ammeters with position switches, a local/remote switch for motor operation, etc.

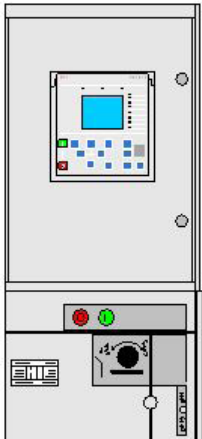

01

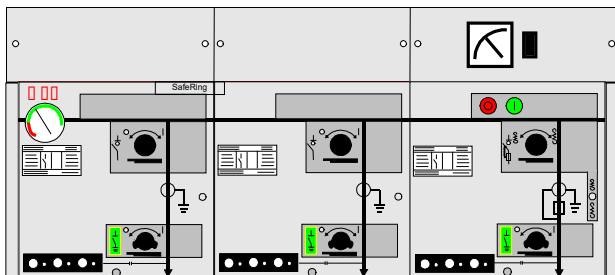

02

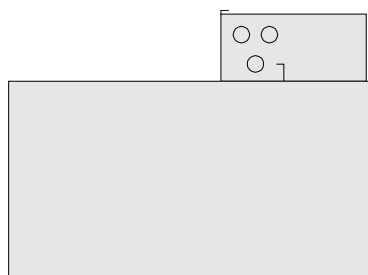

03

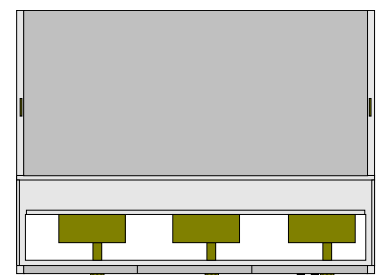

04

19 Motor operation

Closing and opening operations of load-break switches and charging of the springs of the mechanisms for the circuit-breaker and the switch-fuse combination may be performed by motor operation. The disconnecter in the V-module and all earthing switches do not have this possibility. All motor devices require DC voltage. If the control voltage is either 110 or 220 VAC, a rectifier is integrated in the control unit.

The operating cycle for motor operation is CO - 3 min (i.e. it may be operated with a frequency of up to one close and one open operation every third minute). Test voltage for tables below is +10/-15 % for motor operations and closing coils and +10/-30% for trip coils and opening coils. The motor and coils can easily be mounted to the mechanisms after delivery (retro-fit).

Characteristics of motor operation for C-module

Rated voltage (V)	Power consumption (W) or (VA)	Operation times		Peak start current (A)	Fuse
		Closing time (s)	Opening time (s)		
24	90	6 - 9	6 - 9	14	F 6.3 A
48	150	4 - 7	4 - 7	13	F 4 A
60	90	6 - 9	6 - 9	7	F 4 A
110	90	6 - 9	6 - 9	3	F 2 A
220	90	6 - 9	6 - 9	1.7	F 1 A

Characteristics of motor operation for F-module

Rated voltage (V)	Power consumption (W) or (VA)	Operation times		Peak start current (A)	Fuse
		Charge/Closing time (s)	Opening time (ms)		
24	160	9-14	40-60	14	F 6.3 A
48	200	5-9	40-60	13	F 4 A
60	140	8-13	40-60	7	F 4 A
110	140	8-13	40-60	3	F 2 A
220	140	8-13	40-60	1.7	F 1 A

Characteristics of motor operation for V-module

Rated voltage (V)	Power consumption (W) or (VA)	Operation times		Peak start current (A)	Fuse
		Charge/Closing time (s)	Opening time (ms)		
24	180	10-17	40-60	14	F 6.3 A
48	220	5-9	40-60	13	F 4 A
60	150	9-13	40-60	7	F 4 A
110	170	9-13	40-60	3	F 2 A
220	150	9-14	40-60	1.7	F 1 A

Characteristics of shunt trip coils, closing coils and opening coils for F-and V-module

Rated voltage (V)	Power consumption (W) or (VA)	Operation times		Peak start current (A)	Fuse for closing coil Y2 (Opening coil Y1 is unfused)
		Closing time (ms)	Opening time (ms)		
24 V DC	150	40-60	40-60	6	F 6.3 A
48 V DC	200	40-60	40-60	4	F 4 A
60 V DC	200	40-60	40-60	3	F 4 A
110 V DC	200	40-60	40-60	2	F 2 A
220 V DC	200	40-60	40-60	1	F 1 A
110 V AC	200	40-60	40-60	2	F 2 A
230 V AC	200	40-60	40-60	1	F 1 A

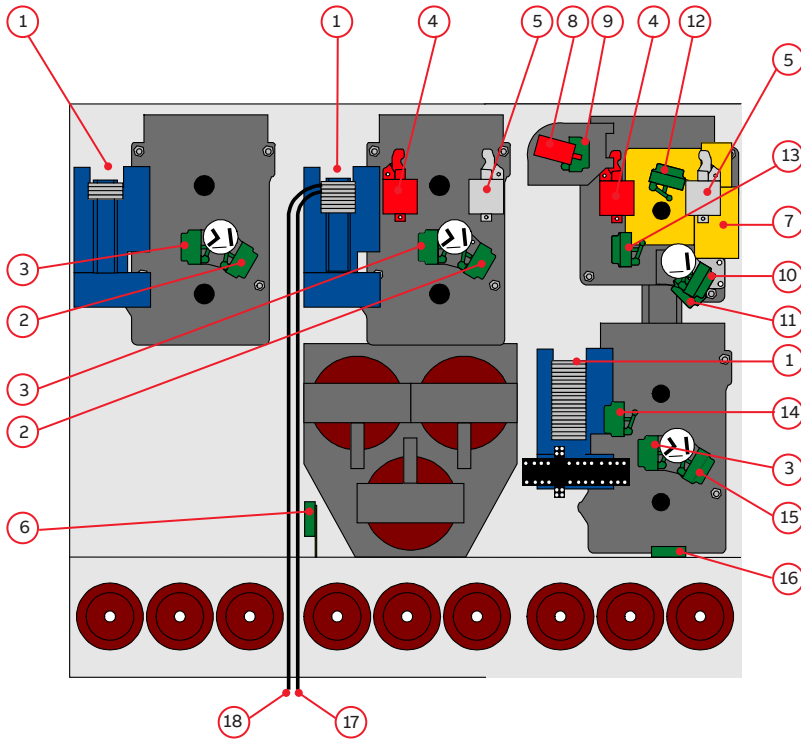

1. Terminal blocks/control unit motor operation
2. Auxiliary switch S7, load break switch
3. Auxiliary switch S10, earthing switch
4. Opening coil Y1
5. Closing coil Y2
6. Auxiliary switch S9, fuse blown
7. Motor operation
8. Relay trip coil Y4 / Y6 / Y9*
9. Auxiliary switch S9, circuit breaker tripped signal
10. Auxiliary switch S5, circuit breaker
11. Auxiliary switch S6, mechanism latched
12. Auxiliary switch S8, spring charged
13. Auxiliary switch S14, operating handle, VCB
14. Auxiliary switch S15, operating handle, disconnecter
15. Auxiliary switch S7, disconnecter
16. Auxiliary switch S13, cable compartment cover
17. Auxiliary switch S20, arc suppressor
18. Auxiliary switch S19, SF₆ gas pressure

* Depending of the type of protection relay, the V module can only be delivered with one of the relay trip coils. Aux powered coils Y4: Relay trip coil (for V-module, 2PA mechanism/circuit breaker)
 Low energy trip coils Y6: trip coil (for V module 2PA mechanism)
 Low energy trip coils Y9: trip coil (for V module EL2 mechanism)

01 SafePlus consisting of CFV modules equipped with various auxiliary switches, coils and motor operation

Motorized disconnecter and earthing switch

Motorization for the earth switch in a C-module and for the earth switch and disconnecter in a V-module is to allow a remote operation of the mechanism in the switchgear. For the earthing switch the auxiliary supply and control cable has to be plugged into the switchgear.

Basic information

- Motor for earthing switch is mounted on the front
- Motor for the disconnecter is mounted behind the panel
- Enable fully remote operation and digital integration
- Control cables are located in LVC
- The motor control is located in a 100mm extension top and leaving more room in the LVC
- All parts of the motor control for the earthing switch is pluggable for easy access and quick assembly
- For manual operation of the earthing switch the motor has to be removed
- Safety is insured by mechanical and electrical interlocks



Motorized earth switch

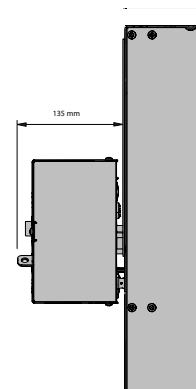

Dimension: The depth of the motor unit

20 Transformer protection

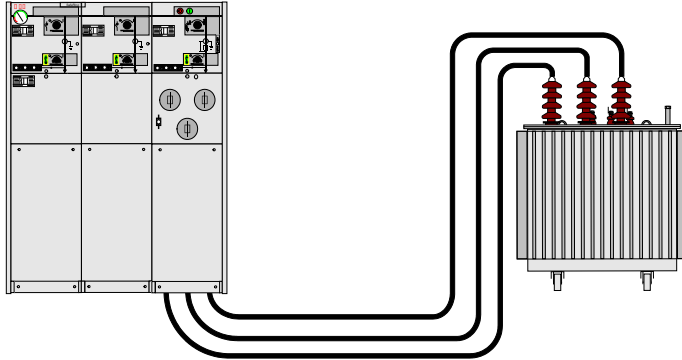

SafeRing / SafePlus offers a choice between a switch-fuse combination and circuit-breaker in combination with relay for transformer protection. The switch-fuse combination offers optimal protection against short-circuit currents, while the circuit-breaker with relay offers better protection against low over-currents. Circuit-breaker with relay is always recommended for higher rated transformers.

SafeRing is delivered with a 200 A rated V-module. SafePlus V-module has two options: 200 or 630 A rating.

Both for SafeRing and SafePlus the relay is a self-powered relay that utilizes the energy from the CTs to energize the trip coil under a fault situation.

The self-powered relay can also be used for cable protection. More details on the different relays can be found in chapter 22 "Protection relays and control products".

Transformer protection with self-powered relay

Recommended types:

- ABB relay type REJ603 v.1.5
- Woodward relays type WIC 1 and WIB 1 PE
- Kries relay type IKI-30/IKI-35

Important features V-module

- Relay behind cover. No need for additional low voltage box for the self-powered relays used for transformer protection.

Typical for vacuum circuit-breaker protection

- Good protection against short-circuits
- Very good for protection of over-currents
- Small fault currents are detected in an early stage

SafeRing / SafePlus - Fuse-link selection

By selection of fuse-links for the protection of a transformer, it is important that requirements in IEC 62271-105 and in IEC 60787 are fulfilled. In particular, Annex A in IEC 62271-105 gives a good example of the coordination of fuse-links, switch and transformer.

Correct selection of fuse-links for the protection of the transformer will give:

- Optimal protection of the transformer
- No damage on the fuse-link's fuse-elements due to the magnetizing inrush current of the transformer
- No overheating of the fuse-links, the switch-fuse combination or the switchgear due to the full load current or the permissible periodic overload current of the transformer
- A transfer current of the combination which is as low as possible, and less than the rated transfer current of the switch-fuse combination
- A situation where the fuse-links alone will deal with the condition of a short-circuit on the transformer secondary terminals
- Fuse-links that discriminate with the low-voltage fuse-links in the event of phase-to-phase faults occurring downstream the low-voltage fuse-links

By carefully checking that these rules are followed, fuse-links from any manufacturer can be used in combination with SafeRing and SafePlus as long as the fuse-links are in accordance with the requirements described in the following pages.

21 Fuse-links



SafeRing / SafePlus is designed and tested for fuse-links produced according to IEC 60282-1. The dimensions of the fuse-links have to be in accordance with IEC 60282-1, Annex D. The fuse-links have to be type I with terminal diameter equal to 45 ± 1 mm and body length (e) equal to 442 mm.

The dimensions of the fuse-links can also be in accordance with DIN 43625 and the length of the fuse canister is based on the use of fuse-links with length 442 mm. For installation of shorter fuses, (<24kV) a fuse adapter will be needed. Please note: When inserting the fuse-link into the canister, the striker-pin must always face outwards against the fuse holder. The fuse adapter has to be fixed to the fuse-link contact that faces inward in the fuse canister. The maximum size of distribution transformer which can be fed from a SafeRing/ SafePlus switch-fuse module is 1600 kVA. For higher rated transformers, we recommend our vacuum circuit-breaker module with CT's and protection relay.

The following table shows CEF fuse-links for use in SafeRing / SafePlus. In order to find the correct fuse-link compared to the transformer rating in kVA, please see the selection tables 21.1.1, 21.1.2 and 21.2.1.

For more technical data, refer to ABB Poland catalogue 2401PL1613-W1-en.

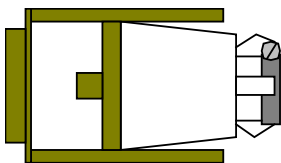

Fuse holder



Fuse-link

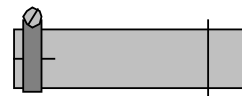

Fuse adapter

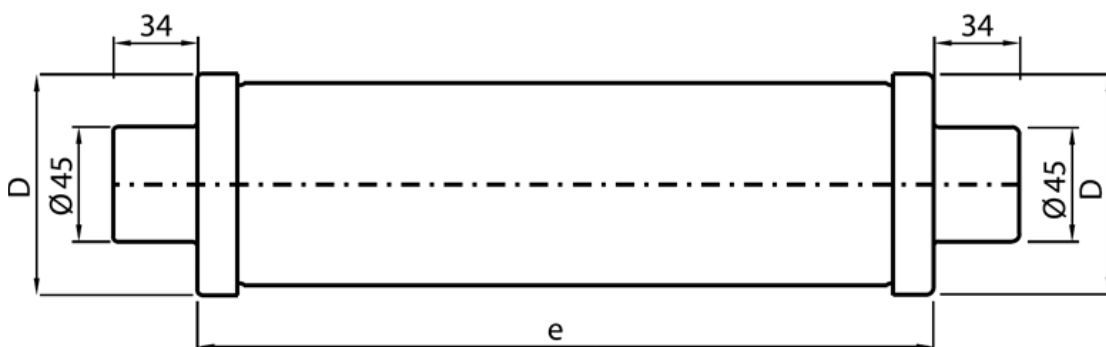

21. Fuse-link table - CEF

Catalog number	Fuse name	Rated voltage [kV]	Rated current [A]	e/D [mm]	Catalog number	Fuse name	Rated voltage [kV]	Rated current [A]	e/D [mm]
1YMB710713M1512	CEF	3/7.2	6.3	192/53	1YMB751744M2512	CEF-VT	10/17.5	2.5	292/53
1YMB710716M1512	CEF	3/7.2	10	192/53	1YMB751746M2512	CEF-VT	10/17.5	5	292/53
1YMB710718M1512	CEF	3/7.2	16	192/53	1YMB711713M2512	CEF	10/17.5	6.3	292/53
1YMB710719M1512	CEF	3/7.2	20	192/53	1YMB711716M2512	CEF	10/17.5	10	292/53
1YMB710721M1512	CEF	3/7.2	25	192/53	1YMB711718M2512	CEF	10/17.5	16	292/53
1YMB710724M1512	CEF	3/7.2	31.5	192/53	1YMB711719M2512	CEF	10/17.5	20	292/53
1YMB710725M1512	CEF	3/7.2	40	192/53	1YMB711721M2512	CEF	10/17.5	25	292/53
1YMB710727M1512	CEF	3/7.2	50	192/53	1YMB711724M2612	CEF	10/17.5	31.5	292/65
1YMB710729M1612	CEF	3/7.2	63	192/65	1YMB711725M2612	CEF	10/17.5	40	292/65
1YMB710731M1612	CEF	3/7.2	80	192/65	1YMB711727M2812	CEF	10/17.5	50	292/87
1YMB710733M1612	CEF	3/7.2	100	192/65	1YMB711729M2812	CEF	10/17.5	63	292/87
1YMB710735M1812	CEF	3/7.2	125	192/87	1YMB711731M2812	CEF	10/17.5	80	292/87
1YMB710738M2812	CEF	3/7.2	160	292/87	1YMB711733M2812	CEF	10/17.5	100	292/87
1YMB751244M2512	CEF-VT	6/12	2.5	292/53	1YMB752409M4512	CEF-VT	10/24	2	442/53
1YMB751211M2512	CEF-VT	6/12	4	292/53	1YMB752444M4512	CEF-VT	10/24	2.5	442/53
1YMB711213M2512	CEF	6/12	6.3	292/53	1YMB752411M4512	CEF-VT	10/24	4	442/53
1YMB711216M2512	CEF	6/12	10	292/53	1YMB712413M4512	CEF	10/24	6.3	442/53
1YMB711218M2512	CEF	6/12	16	292/53	1YMB712416M4512	CEF	10/24	10	442/53
1YMB711219M2512	CEF	6/12	20	292/53	1YMB712418M4512	CEF	10/24	16	442/53
1YMB711221M2512	CEF	6/12	25	292/53	1YMB712419M4512	CEF	10/24	20	442/53
1YMB711224M2512	CEF	6/12	31.5	292/53	1YMB712421M4512	CEF	10/24	25	442/53
1YMB711225M2512	CEF	6/12	40	292/53	1YMB712424M4512	CEF	10/24	31.5	442/53
1YMB711227M2612	CEF	6/12	50	292/65	1YMB712425M4512	CEF	10/24	40	442/53
1YMB711229M2612	CEF	6/12	63	292/65	1YMB712427M4612	CEF	10/24	50	442/65
1YMB711231M2612	CEF	6/12	80	292/65	1YMB712429M4612	CEF	10/24	63	442/65
1YMB711233M2612	CEF	6/12	100	292/65					
1YMB711235M2812	CEF	6/12	125	292/87					

21.1 Fuse selection table - CEF

Table 21.1.1

100%	Transformer rating (kVA)																Fuse-link rated voltage	
U _n (kV)	25	50	75	100	125	160	200	250	315	400	500	630	800	1000	1250	1600		
3	10	20	25	31.5	40	50	50	63	100	125	160	160						
3.3	10	20	25	25	31.5	40	50	63	80	100	160	160	160					
4.15	10	16	20	25	25	31.5	40	50	63	80	100	160	160					
5	10	16	20	20	25	31.5	315	50	50	63	100	100	125	160	160			7.2 kV
5.5	6.3	10	16	20	25	25	31.5	40	50	63	80	100	100	160	160			
6	6.3	10	16	25	25	25	40	40	50	50	80	100	125	160	160			
6.6	6.3	10	16	20	20	25	25	31.5	40	50	63	80	100	100	160			
10	4 ²	10	10	16	16	20	20	25	31.5	31.5	50	50	50	63	100	125		
11	2.5 ²	6.3	10	10	16	20	20	25	25	31.5	40	50	50	63	80	100		12 kV
12	2.5 ²	6.3	10	10	16	16	20	20	25	31.5	40	50	50	63	80	100		
13.8	2.5 ²	6.3	10	10	10	16	20	20	25	25	31.5	40	40	50	63	80		
15	2.5 ²	6.3	10	10	10	16	16	20	20	25	31.5	40	40	50	63	80		17.5 kV
17.5	2 ^{1,2}	5 ²	6.3	10	10	10	16	16	20	25	25	31.5	31.5	40	50	63		
20	2 ^{1,2}	4 ²	6.3	10	10	10	16	16	20	20	25	31.5	31.5	40	50	63		
22	2 ^{1,2}	2.5 ²	6.3	6.3	10	10	10	16	20	20	25	25	25	31.5	40	50		24 kV
24	2 ^{1,2}	2.5 ²	6.3	6.3	10	10	10	16	16	20	20	25	25	31.5	40	50		

- The table is based on using fuses type ABB CEF
- Normal operating conditions with no overload
- Ambient temperature -25°C - +40°C
- ¹Fuse is not able to clear independently transformers secondary side terminals short-circuit current
- ²CEF-VT

Table 21.1.2

120%	Transformer rating (kVA)																Fuse-link rated voltage	
U _n (kV)	25	50	75	100	125	160	200	250	315	400	500	630	800	1000	1250	1600		
3	10	20	25	31.5	40	50	50	63	100	125	160	160						
3.3	10	20	25	25	31.5	40	50	63	80	100	160	160						
4.15	10	16	20	25	31.5	31.5	40	50	63	80	100	160	160					
5	10	16	20	20	25	31.5	31.5	50	50	63	100	100	125	160				7.2 kV
5.5	6.3	10	16	20	25	25	31.5	40	50	63	80	100	125	160				
6	6.3	10	16	20	20	25	31.5	40	50	50	63	100	125	160	160			
6.6	6.3	10	16	20	20	25	25	31.5	40	50	63	80	100	125	160			
10	4 ²	10	10	16	16	20	20	25	31.5	31.5	50	50	63	80	100	125		
11	2.5 ²	6.3	10	10	16	20	20	25	25	31.5	40	50	63	80	100	125		12 kV
12	2.5 ²	6.3	10	10	16	16	20	20	25	31.5	40	50	50	63	80	100		
13.8	2.5 ²	6.3	10	10	10	16	20	20	25	25	31.5	40	50	63	80	100		
15	2.5 ²	6.3	10	10	10	16	16	20	20	25	31.5	40	40	50	63	80		17.5 kV
17.5	2 ^{1,2}	5 ²	6.3	10	10	10	16	16	20	25	25	31.5	40	50	63	80		
20	2 ^{1,2}	4 ²	6.3	10	10	10	16	16	20	20	25	31.5	31.5	40	50	63		
22	2 ^{1,2}	2.5 ²	6.3	6.3	10	10	10	16	20	20	25	25	31.5	40	50	63		24 kV
24	2 ^{1,2}	2.5 ²	6.3	6.3	10	10	10	16	16	20	20	25	40	31.5	40	50		

- The table is based on using fuses type ABB CEF
- Normal operating conditions with 20% overload
- Ambient temperature -25°C - +40°C
- ¹Fuse is not able to clear independently transformers secondary side terminals short-circuit current
- ²CEF-VT

21.2 Fuse selection table - CEF-S

Table 21.2.1

Transformer rated voltage (kV)	Transformer rating (kVA)														Fuse-link rated voltage (kV)	Fuse-link length "e" (mm)	Catalog No. CEF-S	
	25	50	75	100	125	160	200	250	315	400	500	630	800	1000				
Fuse-link rating In (A)																		
6	10	16	20	25	40	40	50	63	63							16/12	292	10A: 1YMB741216M2611
6.6	10*	16	20	25	40	40	50	50							16A: 1YMB741218M2611			
10	10*	10	16	20	20	25	40	40	50	63	63				20A: 1YMB741219M2611			
11	10*	10	16	20	20	25	40	40	40	50	63				25A: 1YMB741221M2611			
12		10	16	16	20	20	25	40	40	50	63	63			40A: 1YMB741225M2611			
															50A: 1YMB741227M2611			
															63A: 1YMB741229M2611			
13.8	10*	16	16	20	20	25	40	40	40	50					10A: 1YMB742416M4611			
15	10*	10	16	16	20	20	25	40	40	50	50				16A: 1YMB742418M4611			
17.5	10*	10	16	16	20	20	20	40	40	40	50	50			20A: 1YMB742419M4611			
20	10*	10*	10	16	16	20	20	25	40	40	50	50			25A: 1YMB742421M4611			
22	10*	10*	10	16	16	20	20	20	40	40	40	50	50		40A: 1YMB742425M4611			
24		10*	10	16	16	16	20	20	25	40	40	50	50		50A: 1YMB742427M4611			
Max.gG fuse-link at LV side (A)	40	80	125	160	160	200	250	250	300	400	400	800						

The table was calculated according to standards IEC 60787 and IEC 62271-105. The following transformer and switchgear operating conditions were assumed:

- Maximum long-lasting transformer overload - 120%,
- Magnetizing inrush current for transformers up to and including 630kVA - 12 x In during 100ms
- Magnetizing inrush current for transformers above 630kVA - 10 x In during 100ms
- Standard ambient working conditions for SafeRing/ SafePlus switchgear (most important: ambient temperature -25 °C to +40 °C)

For ratings marked with "*" fuse is notable to clear independently transformers secondary side terminals short-circuit current.

The table above details the rated current of a particular fuse-link for a given line voltage and transformer rating. For different criteria, the fuse selection must be recalculated.

22 Protections relays and control products



This chapter describes the different choices of protection relays, self-powered protection relays and RTU/control devices that can be used in SafePlus. These protection relays and RTU/control devices require an additional low voltage compartment.

We offer three types of device configuration for our ABB devices:

- No configuration
- Basic configuration
- Customized configurations

No configuration

This configuration option is intended for use where customer supplies the configuration files, non-ABB relays and projects where configuration and/or testing is handled by the customer.

Basic configuration

This configuration option is intended for use where customer needs a premade setup. This setup covers the specific protection relay's base functionality installed in SafeRing/SafePlus switchgears. IED protection and control functionality is tested and documented acc. to Basic setup. Test report and functional description will be supplied upon request.

Customized configuration

This configuration option is intended for use where customer needs a complete setup. IED's are tested and documented. Functional description and test reports will be delivered as part of the switchgear documentation.

For transformer protection with maximum 200A vacuum circuit-breaker see chapter 20, "Transformer protection".

The V-module can also be delivered prepared for specific protection relays or non-specific protection relays:

- Prepared for relays
- Trip coils

Prepared for relays

This option is only for specific protection relays and it includes cut out in LV-compartment, trip coil, aux contacts, wiring and drawings.

Trip coil

This option is more general and includes the trip coil itself, auxiliary contacts, and wires between them.

22.1 Auxilliary powered relays



605 series

The Relion 605 series protection relays feature basic devices that fulfill the essential protection needs in medium-voltage networks. The series is best suited for secondary distribution applications. These relays are well-known for their straight forward approach to protection.



615 series

The Relion 615 series protection relays can be defined as a compact and versatile solution for power distribution in utility and industrial applications. The 615 series provides standard configurations, which allows you to easily adapt and set-up your applications, still allowing you to adapt the configuration according to application specific needs. The protection relays are delivered with a standard configuration for easier and faster relay engineering and shorter time-to-operation. The 615 series combines compactness and powerful features in one smart package.



620 series

The Relion 620 series offers flexibility and performance for demanding power distribution in utility and industrial applications. The series offers wider application coverage in one product compared to the 615 series, which enables wider standardization of the product type in your application. The 620 series protection relays are delivered with an example configuration, which helps adaptation to user specific requirements.



630 series

The Relion 630 series protection relays feature flexible and scalable functionality to adapt to different needs in power distribution networks and industrial applications. The relays contain pre-configured application configurations, which can be tailored to meet the specific requirements for also the most demanding distribution applications.



640

REX640 makes protecting all assets in advanced power generation and distribution applications easy. The fully modular design allows unequaled customization and modification flexibility, and easy adaptation to changing protection requirements throughout the relay life cycle.

22.2 Self powered relays



REJ603 v.3.0



REJ603 v.1.5

REJ603

REJ603 is designed for selective short-circuit and earth-fault protection of feeders in secondary distribution networks and for protection of small transformers in utilities and industries. REJ603 is a current-transformer-powered numerical feeder protection relay designed for applications where auxiliary power is not available or cannot be guaranteed, thereby making it an ideal choice for installation in remote locations. The relay is primarily used in ring main units and secondary distribution switchgear within distribution networks.

REJ603 v.1.5: Functions are easy to set up by using the dip-switches.

REJ603 v.3.0: Contains LCD display, LED indicators and navigation keys. Measurement, events and settings can be viewed in the display.



IKI-30



IKI-35

IKI-30/IKI-35

The Transformer protection relay IKI-30 is applicable for transformers with nominal power between 160 and 12 500 kVA; as overcurrent, short-circuit or earth-fault protection relay in combination with a circuit-breaker and as overcurrent protection in combination with load-break switch and switch-fuse devices. IKI-35 is a self-powered overcurrent protection relay with self test function and event recorder. For transformer or feeder protection with a wide range of CT's.



WIB1



WIC1

WIB1/WIC1

All available versions of the WIB1/WIC1 relay are a high-tech and cost-optimized protection for MV switchgears. Specifically in compact switchboards, the WIB1/WIC1 protection system in combination with a circuit-breaker can replace the combination of load-break switch with HV fuses. The overload protection for the attached unit is clearly improved. When power distribution networks are extended more and more high powered transformers are used and HV fuses are inadmissible. For such applications the WIB1/WIC1 protection system is an optimal replacement.



WIP1

WIP1

The WIP1 is an overcurrent relay with multiple characteristics. Definite time and inverse time tripping characteristics can be selected. Due to its wide setting ranges, the tripping characteristic can be selected to protect a wide variety of different equipment. Optionally the WIP1 is available with earth fault element (option IE) and negative sequence element (option IS).

Technical functions self-powered relays

Functionality		Relays							
Features	Description	IEC 60617	IEEE device no.	REJ603 v.1.5	REJ603 v.3.0	WIC 1	WIB 1	WIP 1	IKI 30
Protection functions	Three-phase transformer inrush detector	3I2f>	68	•	•	-	-	-	•
	Phase overcurrent (multi-characteristic)	3I> (low set)	50/51	•	•	•	•	•	•
	Short-circuit protection	I>>	50/51	•	•	•	•	•	•
	Number of overcurrent elements		50/51B	2	3	2	2	2	2
	Earth-fault current	I0> (low set)	50N/51N	•	•	•	•	•	•
	Number of earth-fault elements			2	2	1	2	2	2
Characteristic curves	Overcurrent element			DEFT,INV ¹⁾	DEFT,INV ¹⁾	DEFT,INV ¹⁾	DEFT	DEFT,INV ¹⁾	DEFT,INV ¹⁾
	Earth-fault current			DEFT,INV ¹⁾	DEFT,INV ¹⁾	DEFT	DEFT,INV ¹⁾	DEFT,INV ¹⁾	DEFT
Additional functions	Trip indication			•	•	• (option)	•	•	•
	Electro-impulse			1	1	1	2	1	1
	input remote tripping (voltage)			-	-	115/230VAC	115/230VAC	230VAC	24VDC/ 115/230VAC
Measuring circuit	Rated secondary current			wide range special CT	wide range special CT	wide range special CT	wide range special CT	ring core CT with I _{sec} = 1A	wide range special CT
	Measuring range, start current I> (A)			7.2	X ²⁾	7.2	7.2	0.17 ³⁾	7.2
Climatic withstand	Storage temperature (°C)			-40 ...+85	-40 ...+85	-40 ...+85	-40 ...+85	-40 ...+85	-30 ...+70
	Operating temperature (°C)			-40 ...+85	-25 ...+55	-40 ...+85	-40 ...+85	-20 ...+55	-25 ...+55

¹⁾ Definite time overcurrent (DEFT), Inverse time overcurrent (INV), please contact us for further information

²⁾ The relay's minimum powering current is 0.07 x I_n when currents in three phase and 0.18 x I_n when current in a single phase

³⁾ Secondary current

Ring core current transformers and earth-fault transformers

REJ603 v.1.5 transformer protection and cable protection kit (self-powered)		
	Ring core current transformer type	Current range
Transformer type	KOKM 072 CT1	8 - 28 A
Transformer type	KOKM 072 CT2	16 - 56 A
Transformer type	KOKM 072 CT3	32 - 112 A
Transformer type	KOKM 072 CT4	64 - 224 A
Transformer type	KOKM 072 CT5	128 - 448 A
WIB1 transformer protection and cable protection kit (self-powered)		
	Ring core current transformer type	Current range
Transformer type	KOKM 072 CT2 or WIC1-W2	16 - 56 A
Transformer type	KOKM 072 CT3 or WIC1-W3	32 - 112 A
Transformer type	KOKM 072 CT4 or WIC1-W4	64 - 224 A
Transformer type	KOKM 072 CT5 or WIC1-W5	128 - 448 A
REJ603 v.3.0 transformer protection and cable protection kit		
	Ring core current transformer type	Current range
Transformer type	KOKM 072 CT2 or WIC1-W2	16 - 56 A
Transformer type	KOKM 072 CT3 or WIC1-W3	32 - 112 A
Transformer type	KOKM 072 CT4 or WIC1-W4	64 - 224 A
Transformer type	KOKM 072 CT5 or WIC1-W5	128 - 448 A

22.3 RTU and control products



RTU520

RTU520

For enhanced observability and complete fault awareness in your power distribution network, RTU520 offers advanced fault and outage management, enabling the efficient detection and isolation of faults and restoration of power and service. With the fault and outage management functionality, outage times can be reduced by up to 81%, leading to an incredible economical advantage.

RTU520 allows accurate energy measurements, based on advanced fault detection equipment. This detailed information are considered the basis for Fault Detection Isolation and Restoration (FDIR), and Fault Location Isolation and Service Restoration (FLISR) functionality. This solution enables a detailed power flow analysis with sensors and measurement devices in MV and LV applications, including smart meter integration. Improving your grid visibility gives you the control you need to take the right decisions at the right time to keep the power flowing.

RTU540

Gateway product for distribution and sub-transmission. Bridges old and new technology and combines existing devices and new standards protocols (such as IEC 61850) in one substation automation system.

RTU540 incorporates advanced features like programmable logic control and a human machine interface allowing for instant insight into the status of the grid. The high-quality, compact metal housing includes input and output modules which lead to space savings in the control cabinet.



RTU540



ARC600

ARC600

The Wireless Controller ARC600 integrates remote control, I/O interface, communications, battery charging and other necessary features for substation automation in a compact, all-in-one package.

ARC600 is optimized for controlling up to three primary switching devices such as sectionalizers, circuit breakers or reclosers. Status indication of the controllable switching devices and up to three earthing switches are also available. ARC600 enables the SCADA system to wirelessly monitor and control the field devices over the public communication infrastructure (cellular network).

Typically, the IEC-104 protocol is utilized for communication to the SCADA system but for the existing installations with a IEC-101 line or modem, Wireless Controller ARC600 supports also IEC-101 communication (including dial-up) to the SCADA system.



ARG600

ARG600

The Wireless Gateway ARG600 provides wireless monitoring and control of field devices via cellular network from a central site or control center. The devices offer industrial quality connectivity for TCP/IP based protocols. Wireless Gateway ARG600 exhibits integrated communication capability and seamless integration to SCADA systems. With the Wireless Gateway ARG600 the Ethernet and serial devices can be attached to a TCP/IP based control system. DNP3.0 serial devices can be also attached to a DNP3 TCP SCADA system. In this case DNP3.0 protocol is transferred just over TCP/IP communication (transparent serial gateway mode).



ARR600

ARR600

Wireless I/O Gateway ARR600 provides wireless monitoring and control of field devices via cellular network from a central site or control center. The devices offer industrial quality connectivity for the IEC 60870 and Modbus based protocols. Field applications can be connected and controlled via built-in digital and analog I/O's. Wireless I/O Gateway ARR600 exhibits integrated communication capability and seamless integration to SCADA systems. The Wireless I/O ARR600 includes integrated digital and analog inputs and outputs. Remote applications, such as overhead sectionalizers, can be connected and controlled via the ARR600. The gateway also serves as a generic I/O interface - for example substation alarms or temperature measurements can be transmitted to a central monitoring system.

23 Capacitive voltage indicators



VPIS



WEGA 1.2C (VDS)



Capdis (VDS)



HR-module (VDS)



VIM 3



VIM 1



PCM

SafeRing / SafePlus switchgears are equipped with voltage indicators in accordance either with IEC 62271-206 standard for voltage presence indication system (VPIS) or IEC 61243-5 standard for voltage detection system (VDS).

Voltage indicators VPIS

VPIS indicators indicate only presence of the medium-voltage. Absence of the voltage needs to be confirmed by use of voltage detection equipment.

Phase comparison and testing of VPIS

Each phase of the integrated voltage presence indicating system has a connection point on the front panel, which can be used to perform phase comparison and to test the voltage presence indicator.

Voltage indicators VDS

VDS is used to detect the presence or absence of medium voltage according to IEC 61243-5. The VDS system delivered by ABB can be either based on the LRM or the HR-system.

Voltage indicators VDS LRM

With the VDS LRM system, the following can be indicated:

- Overvoltage
- Nominal voltage presence
- Isolation problems
- No voltage
- Broken lead indication (Optional feature)

Indication is done visually on the display.

Voltage indicators VDS HR

SafeRing / SafePlus can be delivered with a Voltage Detection System, VDS HR, according to IEC 61243-5. The indicator itself consists of two parts: a fixed part assembled on the switchgear and portable indicator lamps, type VIM-1 and VIM-3, which can be connected to the coupling system interface.

Phase comparator

Phase comparator is used for controlling the phase sequence when connecting two voltage systems together, e.g. during the switching from one source of power supply to another. Phase comparison can be done by any phase comparator according to IEC 61243-5.

Technical functions capacitive voltage indicators								
Manufacturer	Maxeta	Anda	Maxeta	Horstmann	Horstmann	Horstmann	Kries	Kries
Model	VPIS	DNX5	HR module ¹⁾	WEGA 1.2C (45 deg)	WEGA 2.2C (45 deg)	WEGA 1.2C Vario	Capdis S1+(R4)	Capdis S2+(R4)
Type	VPIS	VPIS	VDS	VDS	VDS	VDS	VDS	VDS
Standard	62271-206	62271-206	61243-5	61243-5	61243-5	61243-5	61243-5	61243-5
Capacity variable sec.	no	no	no	no	no	yes	yes	yes
Voltage range	9-15kV 15-24kV	3-6kV 6-12kV 12-24kV 24-40.5kV	6-12kV 12-24kV	3-6kV 6-12kV 10-24kV	3-6kV 6-12kV 10-24kV	Adjustable	Adjustable	Adjustable
Signalling contacts	no	no	no	no	yes	no	no	yes ²⁾
Self testing	external	no	external	internal	internal	internal	internal	internal
Phase comparison	yes	yes	yes	yes	yes	yes	yes	yes
Indicating lamps	yes	yes	Yes (external VIM-1 or VIM- 3)	internal	internal	internal	internal	internal
Resistivity tape	-	-	HR	LRM	LRM	LRM	LRM	LRM
Link up to FPI	no	no	no	Compass B, Sigma D, Sigma D+	Compass B, Sigma D, Sigma D+	-	-	IKI 50
Way of indication	Led lamps	Led lamps	Led lamps (external)	Display, symbols	Display, symbols	Display, symbols	Display, symbols	Display, symbols
External source for testing	no	no	no	no	no	no	no	no
Broken signal leash detection	no	no	no	no	no	no	yes	yes

1) Combination of HR module and combisensor will reduce the tolerance of voltage measurement to approximity 1%. Recommend to use LRM system.

2) For signalling contact, auxiliary voltage is required

24 Short-circuit and earth-fault indicators



Compass B



IKI-50

The increasing demand for reliability and effectiveness of distribution networks requires higher flexibility and more automated ring main units. As one of the biggest players in the medium voltage distribution segment, ABB replies to this demand by installation of grid automation devices. One of the basic devices is the fault passage indicator.

Fault passage indicators

A fault passage indicator may be delivered as an option to the SafeRing / SafePlus switchgear. The indicator is usually placed in the front panel of the switchgear. It makes it possible to detect any faults, including short circuits, earth-faults and short current direction, making it easier to locate any fault.

A fault passage indicator offers different functionalities to the customers, either short-circuit indication which is designed to detect, display and remotely indicate short-circuits in medium voltage distribution networks, or earth-fault indication which is designed to detect, locally indicate and remotely report earth-fault currents in medium voltage distribution networks.

Both functionalities can be combined in one device.

Technical functions; short-circuit and earth-fault indicators

Manufacturer	Horstmann	Horstmann	Horstmann	Horstmann	Horstmann	Horstmann
Model	Sigma	Sigma F+E3	Sigma D	Sigma D+	Compass B	Compass B CS1
Dedicated volt.ind.	-	-	Wega 1.2C/ Wega 1.2 vario/ Wega 2.2C	Wega 1.2C/ Wega 1.2 vario/ Wega 2.2C	Wega 1.2C/ Wega 1.2 vario/ Wega 2.2C	ABB Combi-sensor
STC fault ind.	•	•	•	•	•	•
Directional ind.	-	-	•	•	•	•
Directly earthed neutral	-	•	•	•	•	•
Isolated neutral - Wattmetric (sin)	-	-	-	•	•	•
Compensated neutral - Wattmetric (cos)	-	-	-	•	• (w/ Sum-Sensor) IE>10A	• (IE>10A)
Compensated neutral - transient	-	-	-	•	-	-
Compensated neutral - puls	-	-	-	•	• (only type Bp)	-
Monitoring	•	•	-	-	•	•
Trip current short-circuit	100-1000A	200-2000A	50-2000A	50-2000A	50-2000A	200-2000A
Response time short-circuit	40-80ms	40/80/200/ 300ms	40ms-60s	40ms-60s	40ms-60s	40ms-60s
Trip current earth-fault	-	20-160A	20-1000A (low imp. network)	20-1000A (low imp. network), 5-200A (wattmetric), 10-100A (transient), 1-	20-1000A (low imp. network), 5-200A (wattmetric)	100-1000A (low imp. network), 5-200A (wattmetric)
Response time earth-fault	-	60/80/200/ 300ms	40ms-60s	40ms-60s	40ms-60s	40ms-60s (low imp. network), 200ms-60s (wattmetric)
Remote test/reset	•	•	•	•	•	•
Automatic reset time	1,2,4,8 h	2,4,8,24h	1 min - 24h	1 min - 24h	1 min - 24h	1 min - 24h
Supply	Long life lithium cell	Long life lithium cell	CT powered	CT powered, aux.supply possible: 24V AC, 24-60V DC	24-230V AC/DC (ext)	24-230V AC/DC (ext)
Life time of battery	20 years (batteries)	20 years (batteries)	20 years (batteries)	20 years (batteries)	20 years (batteries)	20 years (batteries)
No. of relay contacts	1	3	4	4	4	4
Comm. protocol	-	-	-	-	Modbus	Modbus
Configuration	DIP	DIP	DIP/SW	DIP/SW	Menu/SW	Menu/SW

Kries	Kries	Kries	Kries	Kries	Kries	Kries	Anda
IKI-50	IKI-50-PULS-EW	IKI-20	IKI-20PULS	IKI-20C	IKI-20C PULS	IKI-22	EKL-7
Capdis S1/S2-R4	Capdis S1/S2-R4					Capdis S1	
•	•	•	•	•	•	•	•
•	•	-	-	-	-	•	-
•	•	•	•	•	•	•	•
-	-	-	-	-	-	•	-
•	•	-	-	-	-	•	-
-	•	-	-	-	-	•	-
-	•	-	•	-	•	-	-
•	•	•	•	-	-	•	-
100-1000A	100-1000A	100-2000A	100-2000A	400-1000A	400-1000A	100-2000A	400,600,800, 1000A
60-1600ms	60-1600ms	60-200ms	60-200ms	100ms	100ms	60-200ms	40,60,80,100ms
40-200A + 4-30A (cosphi methode)	40-200A + 4-30A (cosphi methode) + transient methode	40-200A	40-150A	400-1000A	pulsation	400-200A + transient methode	20, 40, 60, 80A
60-1600ms	60-1600ms	60-200ms	Appr. 9s after detecting pulsating current	100ms	100ms	60-200ms	80, 120, 160, 200ms
•	•	•	•	•	•	•	•
1.8h or automatic after load current is recovered	1.8h or automatic after load current is recovered	2.4h	2.4h	2.4h	2.4h	2.4h	1,2,4,8h
24-230V AC/DC	24-230V AC/DC	3 options: Aux.(ext), capacitor buffered, battery, dep.on version	2 options: Aux.(ext), capacitor buffered, dep.on version	Self-powered + capacitor	Self-powered + capacitor	24-230V AC/DC, only for sensitive earth-fault function + battery	230V AC/DC (ext), 3.6V battery (int)
-	-	17* years (batteries)	12 h for cap. buffering	4 h for capacitor	4 h for capacitor	15 years (batteries)	10 years (batteries)
4	4	1-3 dep. on version	2 dep. on version	2	2	1-3	2
Modbus	Modbus	Modbus	Modbus	-	-	-	-
Menu nav.	Menu nav.	DIP	DIP	DIP	DIP	DIP	DIP

25 Manometers/Pressure indicators



SafeRing and SafePlus are sealed systems designed and tested according to IEC 62271-200 as maintenance free switchgear for lifetime (30 years). The switchgear does not require any gas handling.

ABB applies state of the art technology for gas tightness providing the equipment with an expected leakage rate lower than 0.1 % per annum, referring to the filling-pressure of 1.4 bar*. The switchgear will maintain gas-tightness and a gas-pressure better than 1.35 bar* throughout its designed lifespan. This pressure value is still within a good margin. From the pressure used during type testing, which is 1.3 bar*.

* at 20°C.

For increasing the safety under operation of the switchgear, manometers may be used for each tank.

In case of need of remote indication, manometers can be equipped with signalling contacts. Detailed descriptions of manometer functions are described in the table on next page.

Altitude

Maximum height above sea level for installation without reducing gas pressure is 1500 meters. In the interval from 1500 to 2000 meters, gas pressure has to be reduced. For installation above 2000 meters, please contact ABB for instructions.

Model	Insulation medium	Temp. comp.	Accuracy	Scale range (Absolute)	Appearance (Absolute)	Marking of scale (Absolute)	Over-pressure ind.	Signalling contact	Threshold pressure	Connection to the tank
2RAA017583P0001	SF ₆	X	+/- 1% (20°C)	1 - 2 bar	red zone 1 - 1.2 bar green zone 1.2 - 2.0 bar	mark at 1.2 bar	-	1x NC	1.2 bar	solid
NHP 304769P0001	SF ₆	X	+/- 1% (20°C) +/- 2.5% (-20-+60°C)	1 - 2 bar	red zone 1.0 - 1.2 bar green zone 1.2 - 2.0 bar	mark at 1.4 bar	-	-	-	solid
2RAA014075P0001	SF ₆	X	+/- 1% (20°C) +/- 2.5% (-20-+60°C)	1 - 2 bar	red zone 1.0 - 1.2 bar green zone 1.2 - 1.7 bar yellow zone 1.7 - 2.0 bar	mark at 1.4 bar	X (yellow indication)	-	-	solid
2RAA045613P0001	SF ₆	X	+/- 1% (20°C) +/- 2.5% (-20-+60°C)	0 - 2 bar	red zone 0 - 1.2 bar green zone 1.2 - 1.7 bar yellow zone 1.7 - 2.0 bar	mark at 1.4 bar	X (yellow indication)	1x NO/NC	1.2 bar	solid
Density switch GMD1	SF ₆	X	+/- 2% (-25-+70°C)	-	-	-	-	1x NC	1.15/1.25 bar	solid



2RAA017583P0001

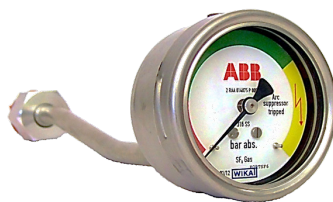

2RAA014075P0001



NHP 304769P0001



GMD1

26 Key interlock

Available key locks are: Ronis, Castell, Kirk and STI. Ronis is default and recommended by ABB. For features, see table on next page.

All load break switches, earthing switches and disconnectors can be equipped with any single key interlock. For double key locks, Ronis is the only type that fits SafeRing / SafePlus switchgears. Key interlocks are not available on fuse-switches or vacuum circuit-breakers.

Example for single key interlock

Key interlocks can be used as follow: Two switchgears A and B are connected to each other by cables. The purpose of interlocks is to prevent closing of the earthing switch unless the load break switch in the other switchgear is locked in the open position.

1. One key interlock will be mounted close to the operating shaft of the load break switch in switchgear A. An identical key interlock will be mounted close to the operating shaft of the earthing switch in switchgear B. As long as the load break switch in switchgear A is in closed position, it will be impossible to remove or operate the key in the key interlock.
2. First you have to operate the load break switch in switchgear A to open position. Then it will be possible to operate the key interlock and turn the key which extends the locking bolt. This will prevent access to the operating shaft of the load break switch. Then withdraw the key and insert it into the identical key interlock on the earthing switch of switchgear B.
3. When the key is inserted you will be able to operate the key interlock and turn the key which will withdraw the extended locking bolt. Then there will be access to operate the earthing switch to closed position. As long as the earthing switch is in closed position, the key will be captured, making it impossible to close the load break switch in switchgear A.
4. If the load break switch in switchgear B and earthing switch in switchgear A are equipped with another identical key interlock which has a different key combination than described above, it will be impossible to make an earth connection of an incoming energized cable from either switchgear A or B.

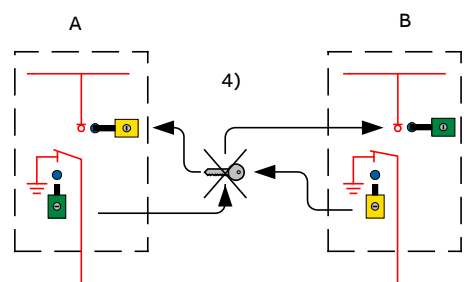
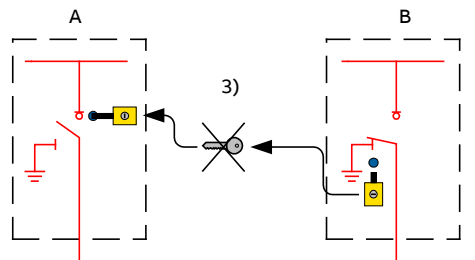
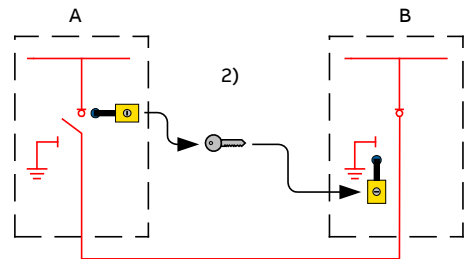
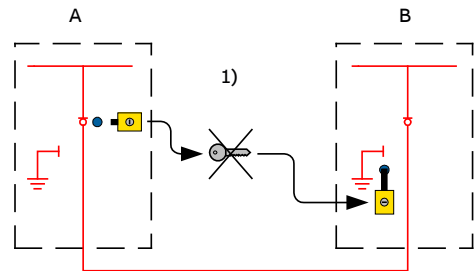

Another example for use of key interlocks is to prevent access to the distribution transformer before the primary side of the transformer is connected to earth. This can be solved by means of two identical key interlocks: one mounted on the earthing switch for the distribution transformer feeder and the other one on the door in front of the transformer.

Types and features of locks

C/SI-module

Type	LBS off	LBS on	ES off single key	ES on	ES on/off	Doorlock
Ronis	•	•	•	•	•	N/A
Castell	•	•	•	•	N/A	N/A
Kirk	•	•	•	•	N/A	N/A
STI	•	•	•	•	N/A	N/A

F-module

Type	LBS off	LBS on	ES off single key	ES on	ES on/off	Doorlock
Ronis	N/A	N/A	•	•	•	N/A
Castell	N/A	N/A	•	•	N/A	N/A
Kirk	N/A	N/A	•	•	N/A	N/A
STI	N/A	N/A	•	•	N/A	N/A

V / V20 / V25 / Sv / Sv20 / Sv25-module

Type	SD off	SD on	ES off single key	ES on	ES on/off	Doorlock
Ronis	•	•	•	•	•	N/A
Castell	•	•	•	•	N/A	N/A
Kirk	•	•	•	•	N/A	N/A
STI	•	•	•	•	N/A	N/A

De/Be-module

Type	LBS off	LBS on	ES off single key	ES on	ES on/off	Doorlock
Ronis	N/A	N/A	•	•	•	N/A
Castell	N/A	N/A	•	•	N/A	N/A
Kirk	N/A	N/A	•	•	N/A	N/A
STI	N/A	N/A	•	•	N/A	N/A

M-module *)

Type	LBS off	LBS on	ES off single key	ES on	ES on/off	Doorlock
Ronis	N/A	N/A	N/A	N/A	N/A	•
Castell	N/A	N/A	N/A	N/A	N/A	•
Kirk	N/A	N/A	N/A	N/A	N/A	•
STI	N/A	N/A	N/A	N/A	N/A	•

Note:
None of the key lock functions in the table above are available for CB-module.
This module has integrated key locks on all push buttons.

*) For M-module, use of an exchange box needs to be considered

27 SafeRing / SafePlus Digital

SafeRing/SafePlus Digital-Enabled switchgears

The SafeRing 12-24 kV ring main unit (RMU) portfolio and the SafePlus 12-24 kV compact switchgear portfolio from ABB is enhanced, with Digital-Enabled functionality to meet the increasing demand for digitalized applications in secondary distribution networks. Our Digital-Enabled switchgears have two possible upgrades, Automation & Control and Monitoring & Diagnostics. Either one of these two upgrades will classify the switchgear as Digital-Enabled.

Digital-Enabled SafeRing/SafePlus switchgears are based on ABB's well-known and established switchgear hardware platforms, combined with equipment giving them remote functionalities, often using sensor technologies for measurements and data collection.

The Integrated option is designed and tailor-made for our SafeRing configurations. All of the necessary equipment is placed inside the switchgear, thereby maintaining the original, compact switchgear design. The Flexible option is designed for our SafePlus portfolio and focuses on modular building blocks that can combine to provide complete functionality for any given use-case.

Customer benefits

The Digital-Enabled switchgears from ABB give network operators the ability to:

- Monitor the switchgear status and network measurements
- Receive quick and accurate notification of any network faults, including localization
- Secure remote operation of the switchgear

This gives our customers the possibility to act quickly to any network changes and remotely reconfigure their network, minimizing any downtime.

Additional benefits for utilities and energy consumers are:

- Improved quality of the power supply
- Fewer and shorter outages and improved voltage quality
- Ensured safety for personnel
- Enhanced operational efficiency and network stability
- Improved tools for network operators and field crews
- Minimized travel to locations with difficult access

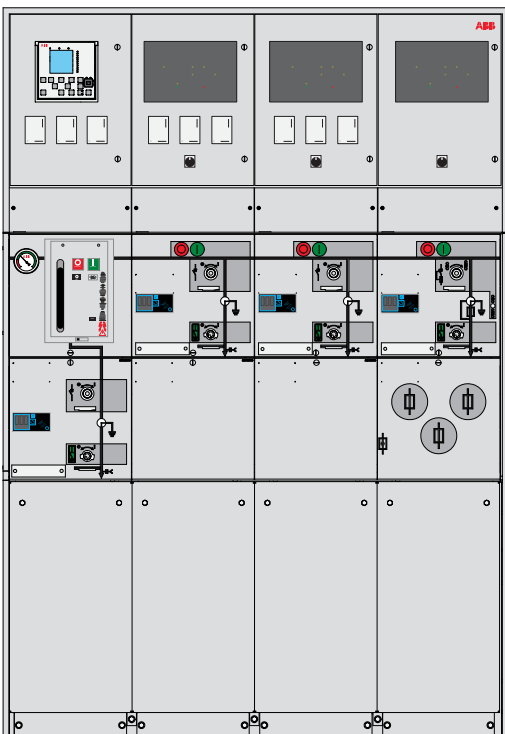

Digital-Enabled switchgear – Integrated option

The Integrated option is a tailor-made solution for our fixed SafeRing configurations. The enabling hardware is placed in the lower mechanism compartment areas behind the lower front cover of the C-, D- or De-modules. This solution maintains the existing compact design and eliminates the need for additional low voltage compartments on the top of the switchgear. Making this a truly integrated and compact solution.

- Smart automation & control
- Wireless external communication
- Programmable local switchgear Controller
- Remote operation of
 - Cable switch (C-module)
 - Switch-fuse (F-module)
 - Vacuum circuit-breaker (V-module)
- Position indication of all the switches
- Directional fault indication
- Digital components placed in lower mechanism compartment
- Flexible sensor solutions (KEVCY or KECA+KEVA)
- Software solutions tailored to the customer needs
- A truly compact design with Digital functionalities
- Possible to use the 26Ah battery back-up solution in lower mechanism compartment
- Available for SafeRing & SafePlus configurations (DeF, CCF, CCFF, CCCF, CCC, CCC, DeV, CCV, CCCV & CCVV)

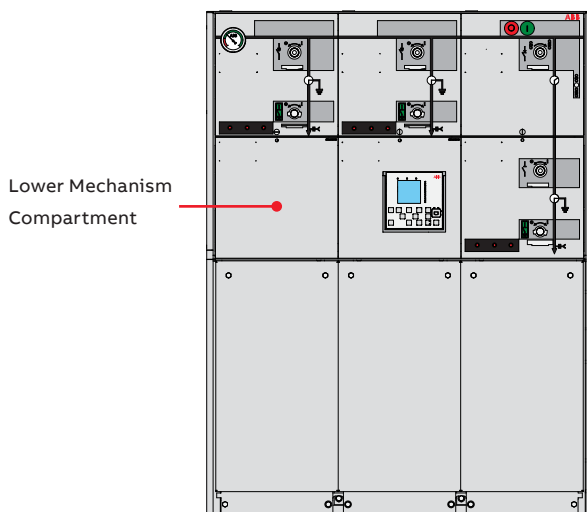

CCV with REC615

Digital-Enabled switchgear – Flexible option

The Flexible option for Digital-Enabled switchgears focuses on the same key-feature as our SafePlus portfolio, modular-flexibility. This is why our Flexible option is only available for SafePlus switchgears.

This Flexible solution has a modular design and gives the customer the freedom to configure and mix switchgear-modules as they wish, while maintaining the overall digital functionality.

- Smart automation & control
- Wireless external communication
- Programmable local switchgear Controller
- IEC 61850 internal communication
- Advanced protection relay options
- Remote operation of
 - Cable switch (C-module)
 - Switch-fuse (F-module)
 - Vacuum circuit-breaker (V-module)
- Position indication of all the Switches
- Directional fault indication
- Digital components placed in LVC
- Flexible sensor solutions (KEVCY or KECA+KEVA)
- Software solutions tailored to the customer needs
- A truly flexible design suitable for customer specific applications and needs
- Possible to use the 26Ah battery back-up solution in lower mechanism compartment
- Available for SafePlus

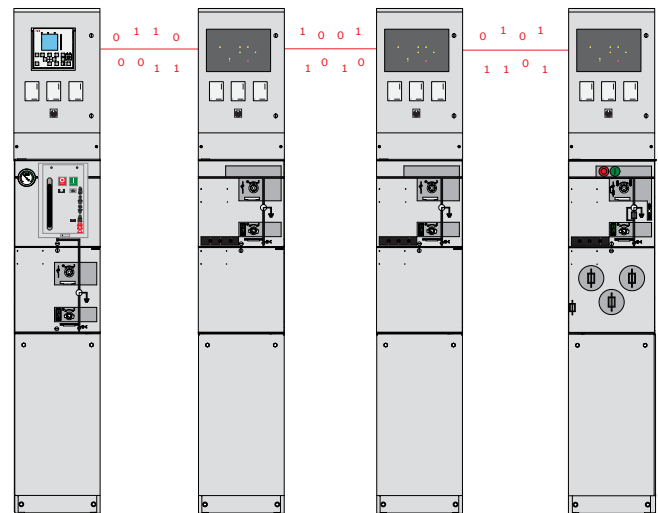

27.1 Components used in Digital-Enabled switchgears

Both Digital-Enabled switchgear options are based upon the same components. The Integrated option has optimized components for a specific SafeRing switchgear configuration. In contrast, the Flexible option for SafePlus focuses on targeted component selection to ensure maximum modular and functional flexibility.



Wireless Gateway options:

The ABB Arctic family offers a range of products that provide reliable and secure wireless communication solutions. The solution utilizes existing public cellular networks that are available worldwide. Selected devices from this family are used in the Digital enabled switchgear.

ARG600 – the ARG600 is a flexible wireless gateway that supports all communication needs of a Digital enabled switchgear. Featuring application independence, connected switchgear can successfully communicate with any central application.

ARR600 – incorporates the benefits of the ARG600 Wireless gateway, the ARR600 also includes integrated I/O that can be directly controlled remotely.

ARG600	ARR600
	LTE (GPRS/3G compatible)
	TCP/IP router
	Protocol converter
	Serial over TCP/IP
	VPN and Firewall
Dual SIM varaiant available	-
-	Integrated I/O

Controller options:

REC615 – is a dedicated grid automation intelligent electronic device (IED) designed for remote control and monitoring, protection, fault indication, power quality analysis and automation in medium voltage secondary distribution systems. Such systems include networks with distributed power generation and secondary equipment such as medium voltage disconnectors, switches and ring main units.

The REC615 device is a perfect controller option for Digital enabled switchgears that can utilize both the controller and protection functionality of the device. These switchgears are usually combinations of C-/D-/De- and V-modules.

- Control and protection relay
- Advanced earth fault protection
- Wide range of communication protocols and interfaces
- Sensor support for measuring current and voltage

External IO option:

RIO600 – is designed to expand the digital and analog I/O of ABB's Relion® protection and control relays and provide I/O connectivity to other ABB products like COM600 or ARC600. RIO600 communicates via IEC 61850 and Modbus TCP communication. Both galvanic RJ-45 and optical LC type connectors are supported for Ethernet station bus communication.

RIO600 can also be used for fault passage indication and power quality measurement, reporting values directly to a peer protection relay or to an upper level system. RIO600 accepts three phase sensor signals (voltage and current) and provides fault detection and metering functions.

- Wide range of I/O modules
- Configurable logic
- Fault indication
- Supports IEC 61850 and Modbus TCP
- Tailor made solution with REx615

ARC600 – the Wireless Controller ARC600 is a compact, solution-orientated device for the remote control and monitoring of secondary substations such as network disconnectors, load break switches and ring main units in distribution networks.

The ARC600 enables the network control system to monitor, control and measure the field devices over the public communication infra-structure (LTE). The Wireless Controller ARC600 utilizes the built-in GPRS for reliable and secure end-to-end communication providing remote monitoring and control of up to three switching devices.

- LTE (GPRS/3G compatible)
- Protocol converter
- TCP/IP router
- VPN and Firewall
- Control and indication of three switching devices
- Battery charging functionality

Sensors:

KEVCY 24 RE1 – is a compact bushing type sensor that provides voltage and current measurement. For more information on this sensor see chapter 10.

KECA 80 C85 – is an indoor current sensor that measures around the bushing. For more information on this sensor see chapter 11.

KECA 80 D85 – is an indoor split core current sensor that measures around the cable. This current sensor can be used for retrofit purposes as well as in new installations. For more information on this sensor see chapter 11.

KEVA 24 C – is an indoor voltage sensor designed to easily replace the insulating plugs normally used in the cable T-connectors. Due to their compact size and optimized design, these sensors can be used for retrofit purposes as well as in new installations. For more information on this sensor see chapter 11.

27.2 Component configuration

Each Digital-Enabled switchgear can be configured and below is a description of the possible configuration choices.

Select a local switchgear Controller:

- **ARC600** – is an ideal Controller selection for simpler switchgear configurations where monitoring and/or remotely operated modules are the key feature
- **REC615** – is an ideal Controller selection for switchgear configurations where the protection relay functionality can be utilized or if its par of a complex switchgear configuration combining several Relion products
- **RTU540** – is still available as customized options

For REC615 or RTU540 Controller – select a wireless gateway ARG600 or ARR600

Switchgear modules functionality – External IO

External IO selection is module-based where the functionality of the IO for each module can be specifically selected.

RIO600 Monitoring – this External IO option uses RIO600 (DIM8) to monitor the following in its respective module:

- Position indication of all switches
- Fuse Blown Signal (hardwired to RIO600)
- Relay Tripped signals (hardwired to RIO600)
- 3rd party FPI signal (hardwired to RIO600)

RIO600 Control – this External IO option uses RIO600 (DIM8) to monitor and has the same monitoring setup as described for **RIO600 Monitoring** above. Additionally, this External IO option uses RIO600 (SCM8) to remotely control the following in its respective module:

- Cable switch (C-module)
- Switch-fuse (F-module)
- Vacuum circuit-breaker (V-module)

Measurement and Fault Indication – this External IO optional add-on uses **RIO600** (SIM8F or SIM4F) for Fault Passage Indication and Measurement functionality on the respective module. This is available with either RIO600 Monitoring or RIO600 Control functionalities. Note: Compatible sensors are required to achieve this functionality.

Customized application

For SafePlus Digital enabled switchgears with Flexible option, the External IO setup be extended and tailor-made for the customer. Consult with your local ABB representative to plan your specialized application.

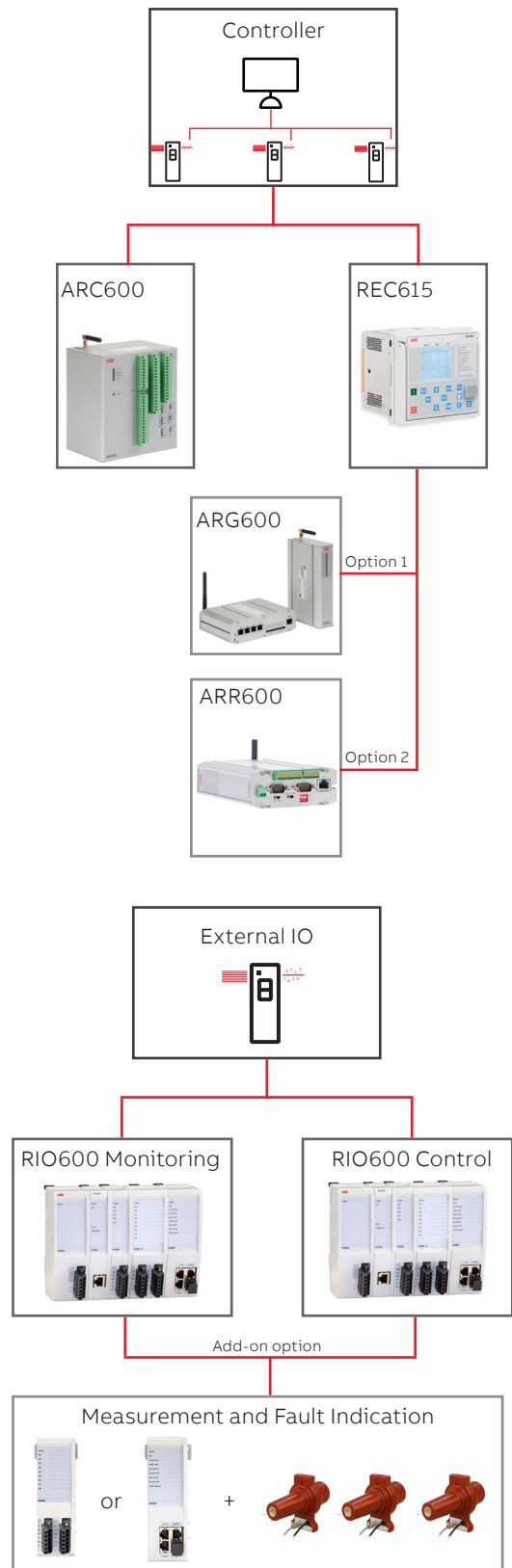

28 Marine applications

SafePlus switchgear is type-certified by Lloyds Register for marine, offshore and industrial applications in environmental categories ENV1 and ENV2 as per Lloyd's Register Type Approval System.

Available functional units for marine applications are:

- Switch disconnecter module (C)
- Circuit-breaker module (V)

The switchgear is delivered for ratings up to 24 kV and can be manufactured with any combination of the above modules, from 2 up to 5 modules.

SafePlus switchgear for Marine applications provides ingress protection IP 22C as a standard feature.

Available DNV certified ABB protection relays:

- REX615
- REX630

Optional arc suppressor to avoid any damages occurring in case of an internal arc inside the gas tank is available.

The solid bottom gland plate allows for installation on open floor structures maintaining the IAC AFL classification.

Dimensions	
Height	1880 mm
Width	696, 1021, 1346 and 1671 mm (1, 2, 3, 4, 5 functional units)
Depth	765 mm for RMU, 1060 mm including roof

Other data/parameters are identical to data for standard SafePlus.



28.1 Marine applications IAC AFL

IAC AFL for marine version of SafePlus

With this set-up, hot gases and pressure are evacuated behind the switchgear through the pressure flap.

Basic parameters of set-up:

- IAC AFL up to 20 kA / 1 s
- Minimum height of ceiling: 2085 mm
- Minimum distance from backwall: 390 mm
- Recommended distance to sidewall is minimum 300 mm

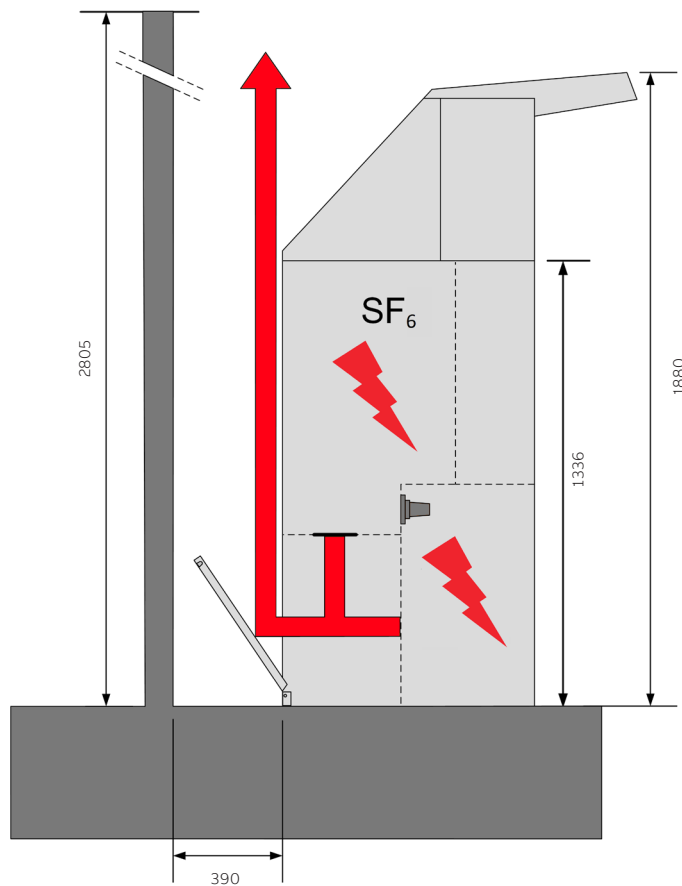

29 Low version switchgear



Available functional units for low version applications are the same as for standard SafeRing/SafePlus, except for the metering and CB-modules.

The switchgear is delivered for ratings up to 24kV and can be manufactured in any combination of the SafeRing / SafePlus modules, from 1 up to 5 modules.

Optional arc suppressor to avoid any damages occurring in case of an internal arc inside the gas tank is available.

- CT's must be placed beneath the switchgear
- Height: 1100 mm
- Same width as standard units
- Only arc proof cable compartment door is available

IAC AFL for low version of SafePlus

For the low-version switchgear, AFL is the highest IAC-classification. Available solutions are blow-out down to cable trench.

Basis parameters of set-up:

- IAC AFL up to 20 kA / 1 s
- Minimum height of ceiling for blow-out down to cable trench: 2000 mm
- Minimum height of ceiling for blow-out behind switchgear: 2400 mm
- Minimum distance from backwall: 100 mm

Parameters and technical data are the same as for standard SafeRing / SafePlus.

30 Battery back-up solutions

In the event of disruption to the auxiliary power supply, included batteries ensure uninterrupted operation of system critical components like protection relays. While on battery power, information can still be sent to central SCADA including switch states and remote operation of compatible switches remains available so that network reconfiguration can be achieved remotely.

Operating times when using battery-backup is often between 24-48 hours. This standby time is affected by the number of connected devices and derating from storage in extreme cold climatic conditions.

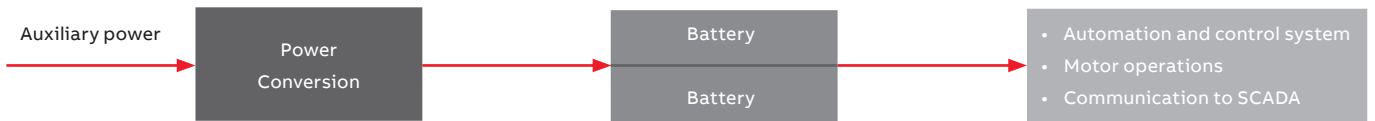

26Ah Battery back-up solution

The 26Ah battery back-up solution is a 24 VDC with 26Ah output solution comprised by 2x 12 VDC, 26Ah Haze GEL batteries and a Power Conversion setup where we use an ADC 5000 Series battery charger.

This 26Ah battery back-up solution can be placed inside the lower mechanism compartment of a C-, D- or De- module.



HZY -EV12-26

26Ah Battery back-up solution in Lower Mechanism Compartment

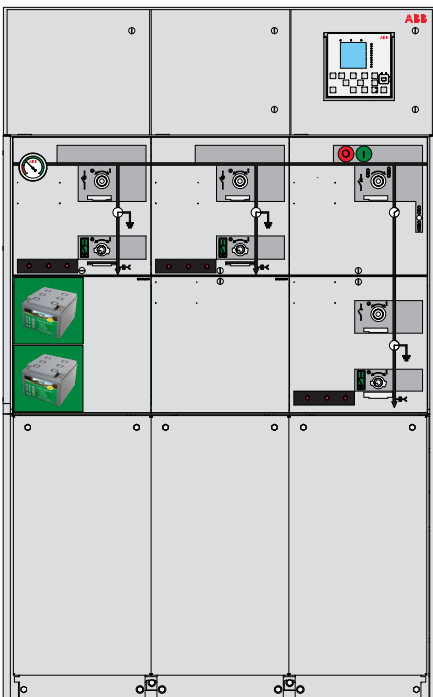

33Ah Battery back-up solution

The 33Ah battery back-up solution is a 24 VDC with 33Ah output solution comprised by 2x 12 VDC, 33Ah Haze GEL batteries and a Power Conversion setup where we use an ADC 5000 Series battery charger.

This 33Ah battery back-up solution is installed in the low voltage compartment.



HZY-EV12-33

33Ah Battery back-up solution in Low Voltage Compartment (LVC)

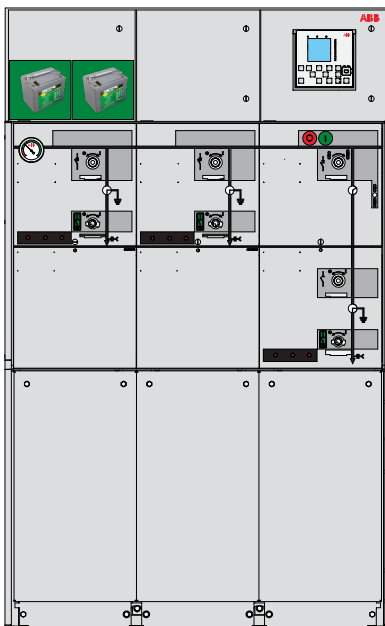

300mm LVC

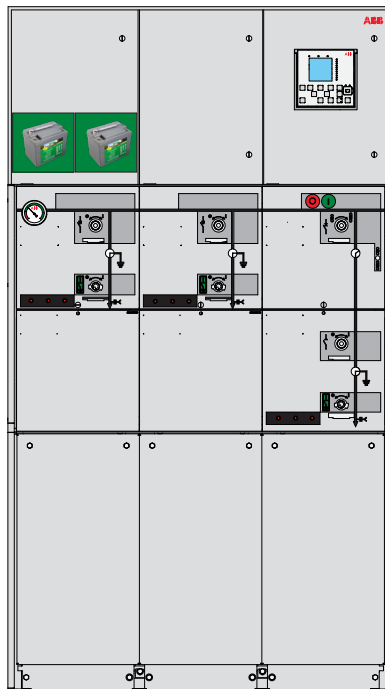

470mm LVC

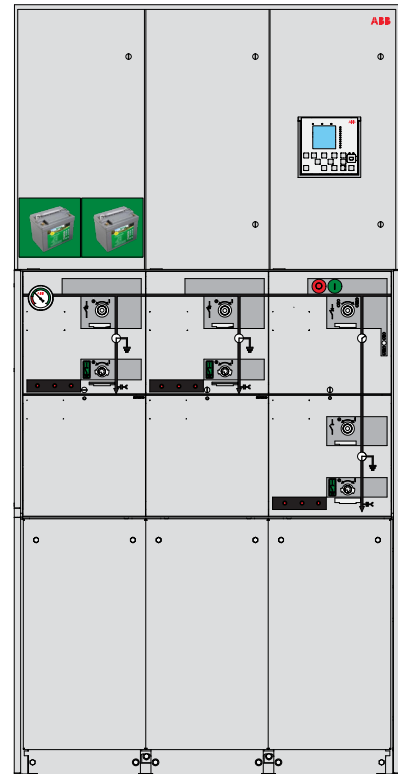

700mm LVC

Power Conversion

Battery charger:

- ADC 5000 Series
- 60 watt (Usually used for SmartGrid solutions)
- 125 watt (standard)
- Input voltage: 90...264 VAC
- Frequency: 45...65 Hz
- Output voltage: 24 VDC
- Operating temp without power loss: -40...55°C



ADC 5000 series

31 Outdoor enclosure

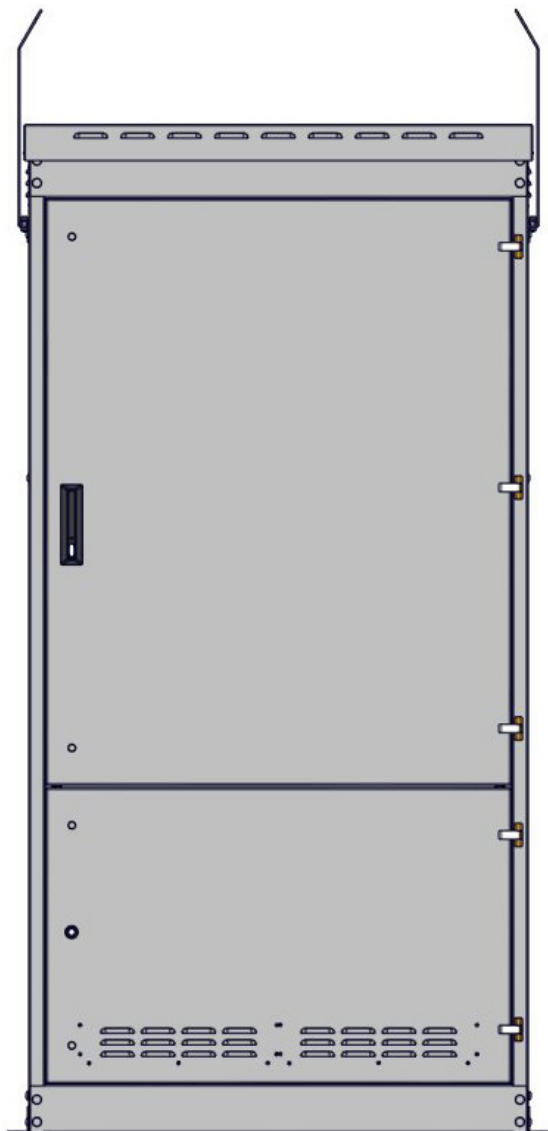

Outdoor enclosure is a water proof cabinet which protects the switchgear from outdoor conditions. Note that the outdoor enclosure may be installed in restricted areas only. Every offer needs to be discussed with ABB sales representative.

Basic parameters for setup:

- Available for 2-5 way unit in low version
- Available for 3-5 way unit in high version
- IP 54

Module	Width (mm)	Height (mm)	Depth (mm)	Weight (kg)
2-way low	812	1760	1030	160
3-way low	1137	1760	1030	190
3-way high	1137	2255	1030	215
4-way low	1462	1760	1030	245
4-way high	1462	2255	1030	260
5-way low	1787	1760	1030	255
5-way high	1784	2255	1030	285

32 Dimensions

Standard

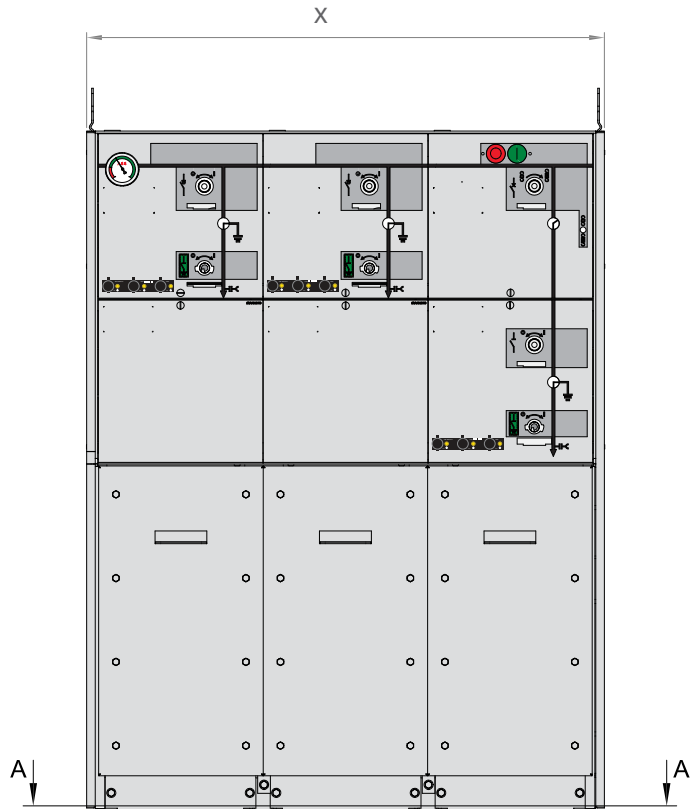
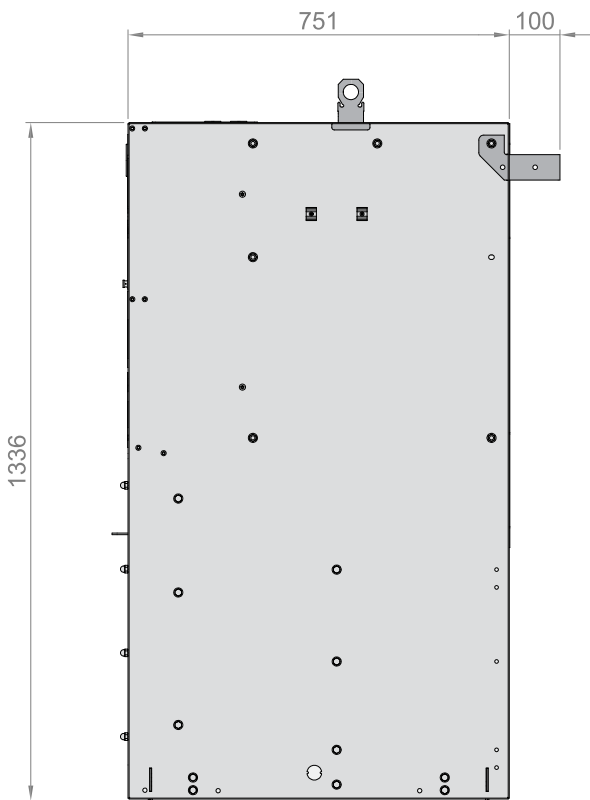

Module	X (mm)	Y (mm)
1-way	370	297
2-way	695	622
3-way	1020	947
4-way	1345	1272
5-way	1670	1597

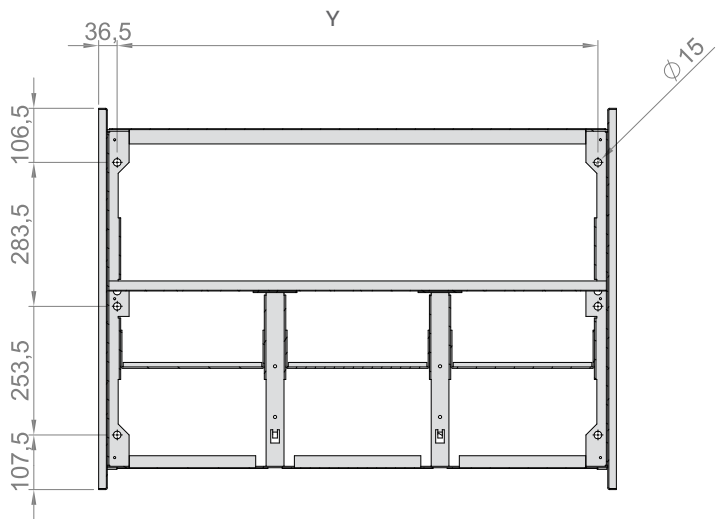

SECTION A-A

AFLR, with exhaust channel, base frame and low voltage compartment

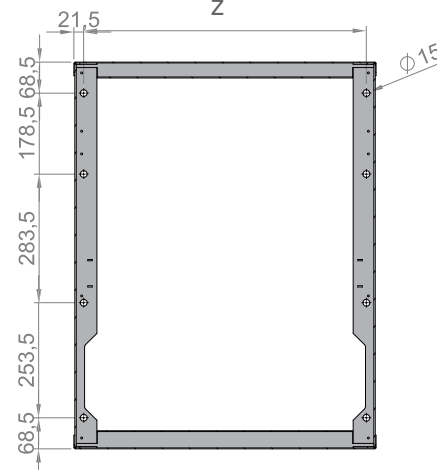
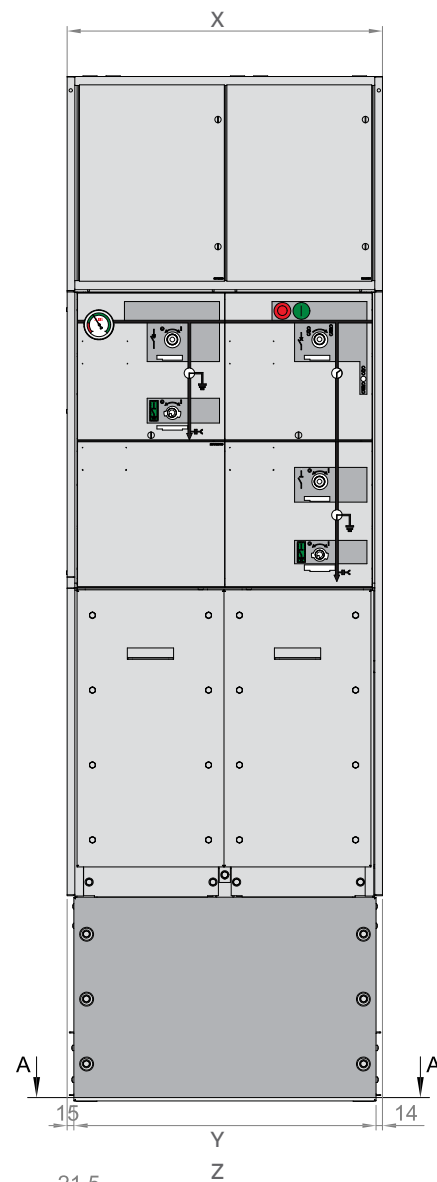
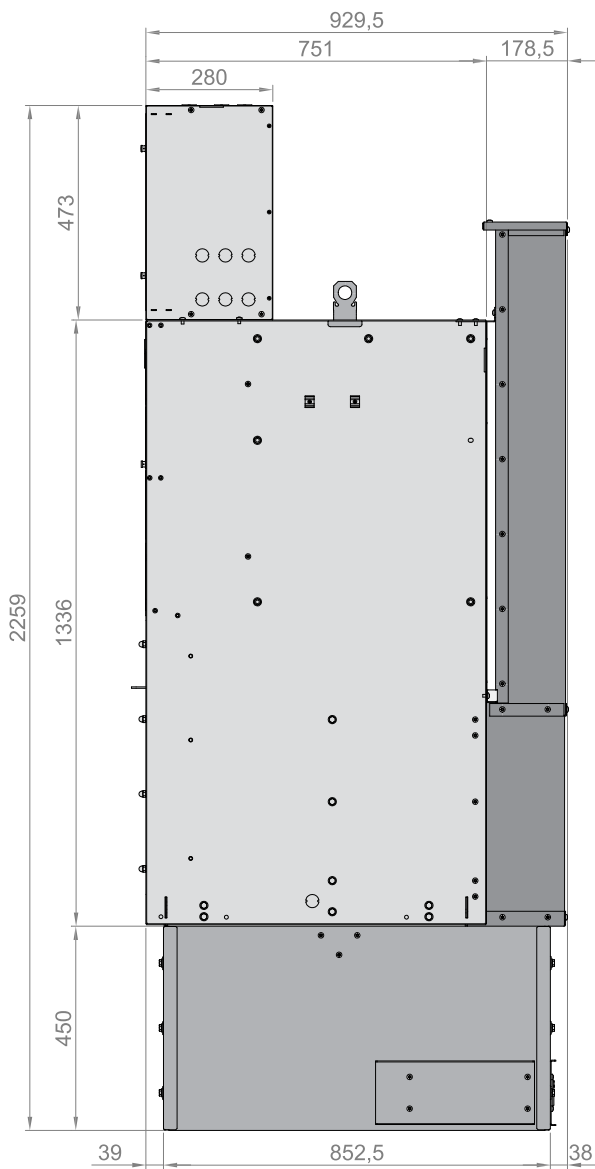

Note: Height of exhaust channel is always 2002 mm, according to requirements in IEC standards. When base frame is 290 mm, the exhaust channel is extended to reach 2002 mm height.

Module	X (mm)	Y (mm)	Z (mm)
1-way	NA	NA	NA
2-way	695	666	623
3-way	1020	991	948
4-way	1345	1316	1273
5-way	1670	1641	1598

SECTION A-A

—
CCF

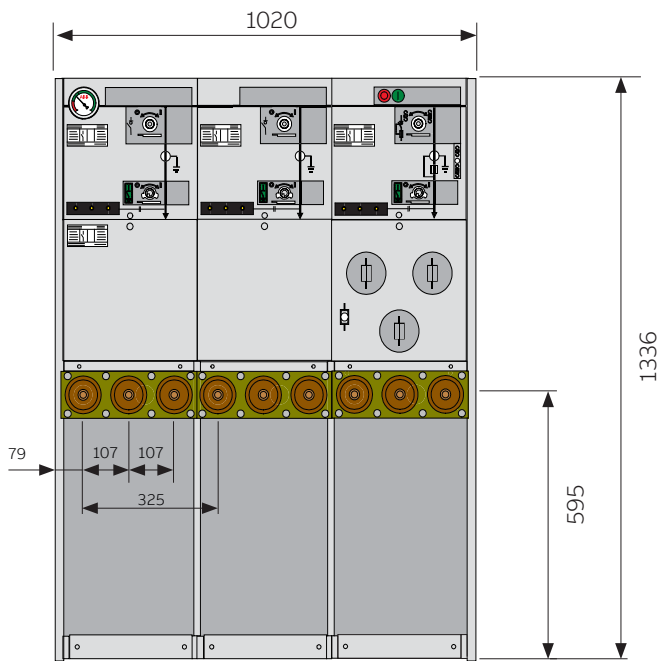

—
CB-module

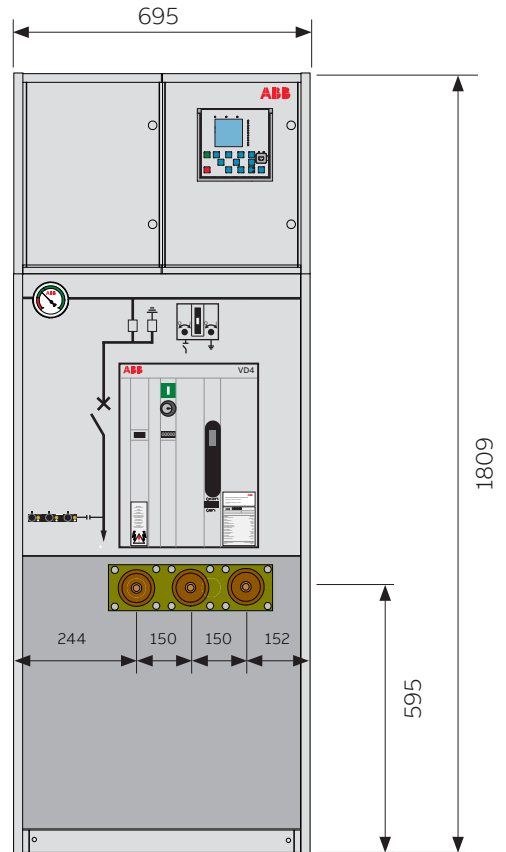

—
Metering-module

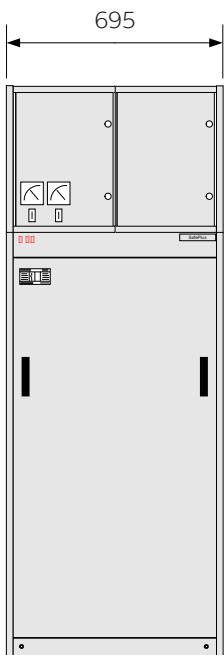

Metering module M, front view

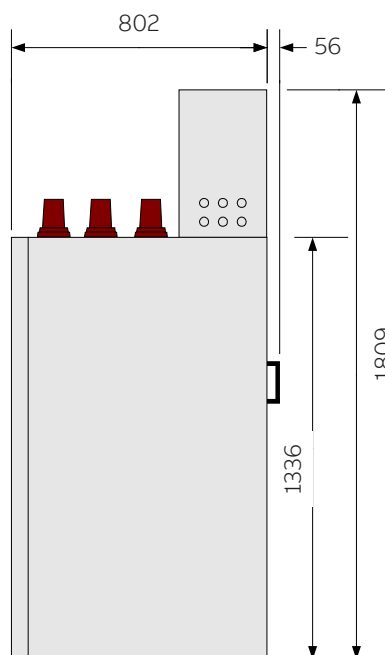

Metering module M, side view

Top entry box

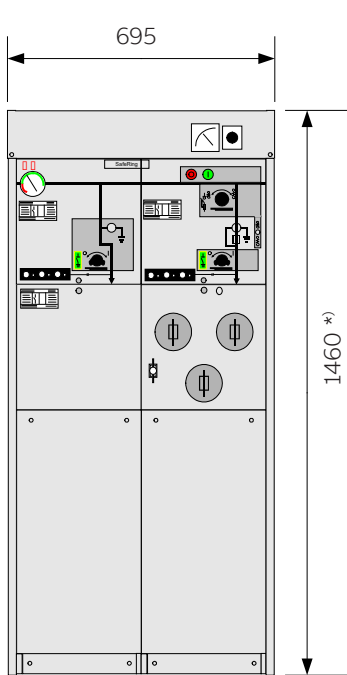

Top entry box with ammeter and position switch
*) standard height for switchgear with V20/V25

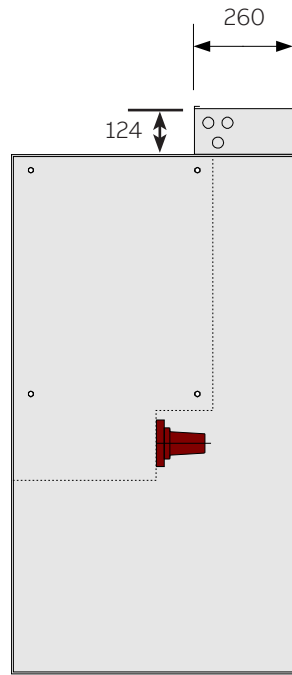

Top entry box - side view

Low voltage compartment with relays

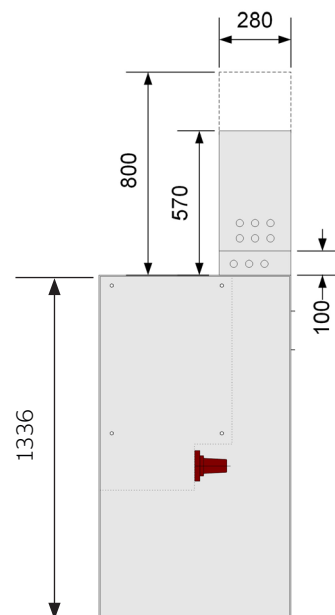
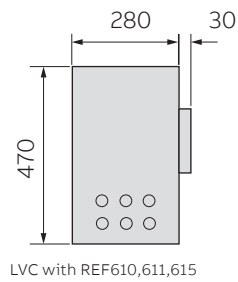
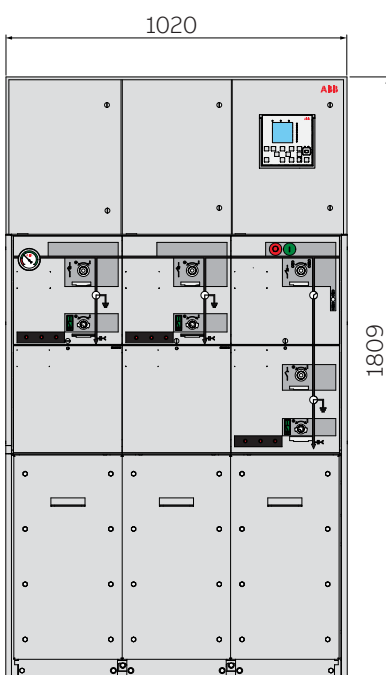

Low voltage compartment for V20/V25

Standard compared to low version



Lower version is an optional solution.

Operating handle

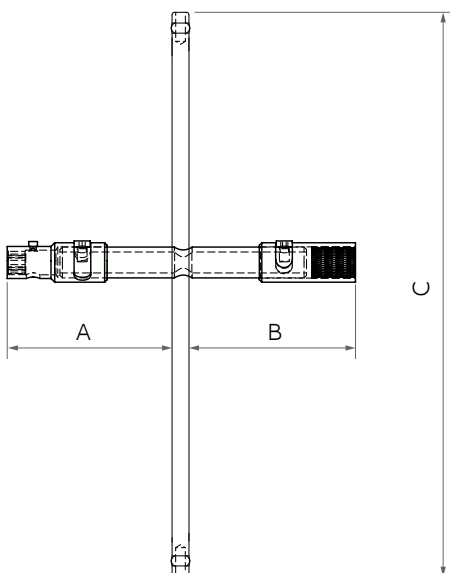

Dimensions operating handle			
Part no.	1VDP000443R1	1VDP000437R1	2RAA027294A1
Description	Standard	Long shaft	Extra long shaft
A	136 mm	293 mm	443 mm
B	133 mm	290 mm	440 mm
C	373 mm	473 mm	473 mm

Bushing on top

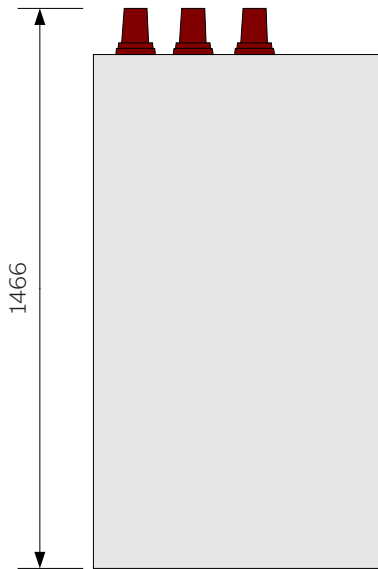

Bushings for connection of external busbars

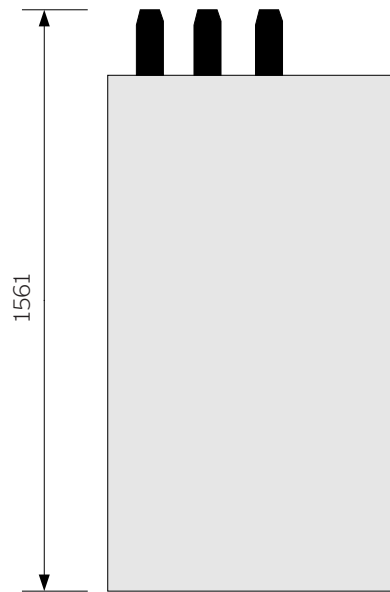

Prepared for future extension with dead end receptacles

Busbar cover

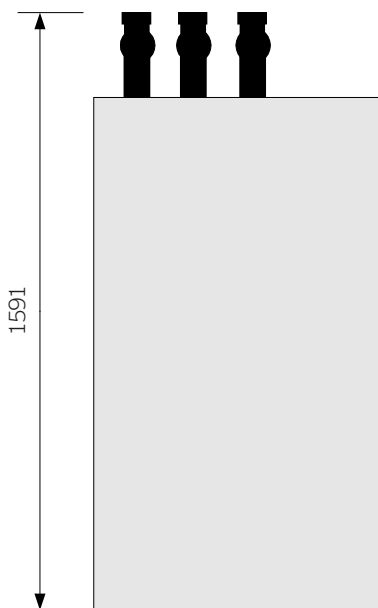

External busbars

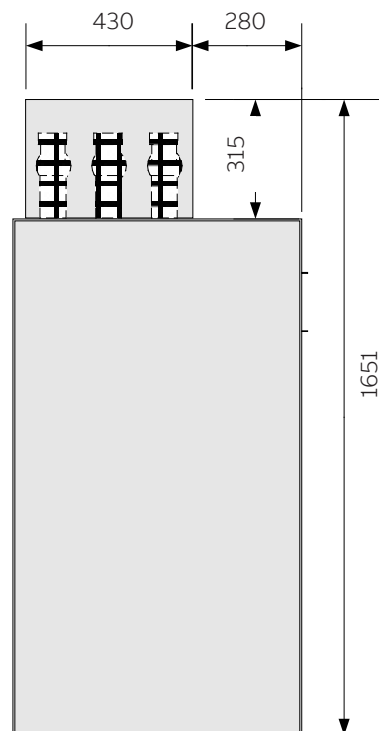

Busbar cover

Extended cable cover

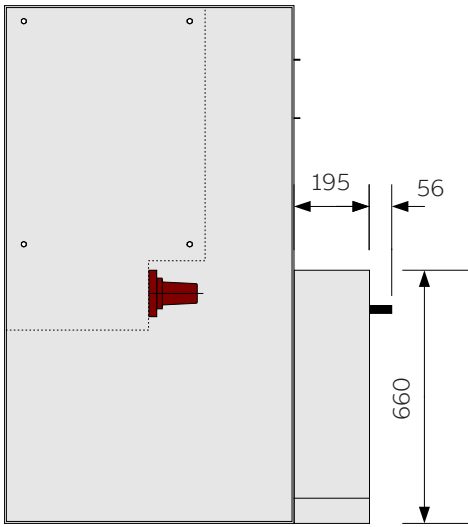

Extended cable compartment cover

33

Arc proof cable cover

Base frame

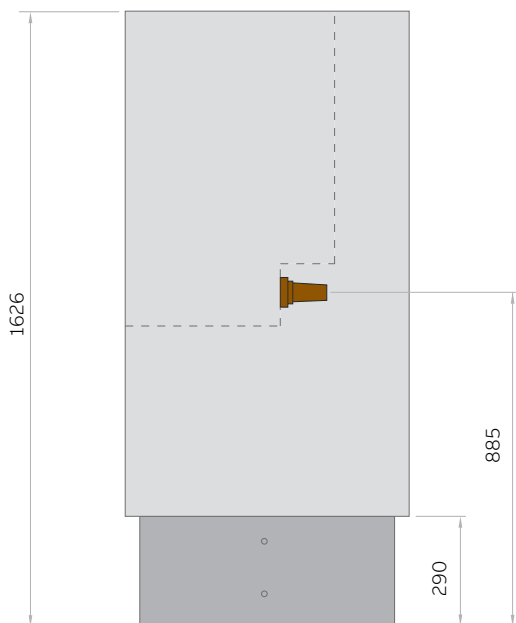

Switchgear with 290mm base frame

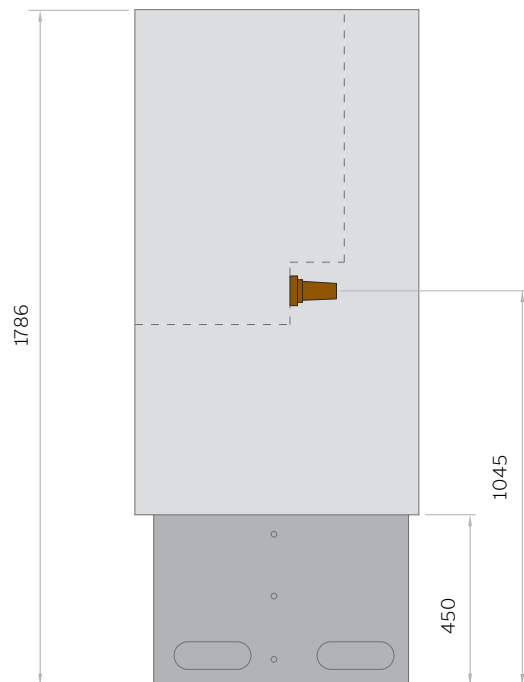

Switchgear with 450mm base frame

Height table

Height (mm)		Standard switchgear					Lower version switchgear		
		Non IAC/IAC AFL without base frame	Non IAC/IAC AFL with 290 mm base frame	Non IAC/IAC AFL with 450 mm base frame	IAC AFLR with 290 mm base frame	IAC AFLR with 450 mm base frame	Non IAC/IAC AFL without base frame	Non IAC/IAC AFL with 290 mm base frame	Non IAC/IAC AFL with 450 mm base frame
without low voltage compartment or top entry box	Standard	1336	1626	1786	2002	2002	1100	1390	1550
	Top connection without dead ends	1466	1756	1916	2002	2002	1230	1520	1680
	Top connection with dead ends	1561	1851	2011	2002	2002	1325	1615	1775
	External busbars	1591	1881	2041	2002	2041	1355	1645	1805
	Busbar cover	1651	1941	2101	2002	2101	1415	1705	1865
with top entry box (124 mm)	Standard	1460	1750	1910	2002	2002	1224	1514	1674
	Top connection without dead ends	1466	1756	1916	2002	2002	1230	1520	1680
	Top connection with dead ends	1561	1851	2011	2002	2011	1325	1615	1775
	External busbars	1591	1881	2041	2002	2041	1355	1645	1805
	Busbar cover	1651	1941	2101	2002	2101	1415	1705	1865
with low voltage compartment (473 mm *)	Standard	1809	2096	2256	2096	2256	1570	1860	2020
	Top connection without dead ends	1809	2096	2256	2096	2256	1570	1860	2020
	Top connection with dead ends	1809	2096	2256	2096	2256	1570	1860	2020
	External busbars	1809	2096	2256	2096	2256	1570	1860	2020
	Busbar cover	1809	2096	2256	2096	2256	1570	1860	2020
with low voltage compartment (700 mm *)	Standard	2036	2326	2486	2326	2489	1800	2090	2250
	Top connection without dead ends	2036	2326	2486	2326	2486	1800	2090	2250
	Top connection with dead ends	2036	2326	2486	2326	2486	1800	2090	2250
	External busbars	2036	2326	2486	2326	2486	1800	2090	2250
	Busbar cover	2036	2326	2486	2326	2486	1800	2090	2250

*) For V-module 12kV/25kA and 24kV/20kA height of low voltage compartment is 570 / 800 mm, so 100 mm has to be added to the total switchgear heights in the table

33 Technical data

Codes and standards

SafeRing / SafePlus are manufactured and tested in accordance with the latest version of the below IEC regulations

IEC 62271-1	Common specifications for high-voltage switchgear and controlgear standards
IEC 62271-100	High-voltage switchgear and controlgear - Part 100: Alternating current circuit-breakers
IEC 62271-102	High-voltage switchgear and controlgear - Part 102: Alternating current disconnectors and earthing switches
IEC 62271-103	High-voltage switchgear and controlgear - Part 1: Switches for rated voltages above 1 kV up to and including 52 kV
IEC 62271-105	High-voltage switchgear and controlgear - Part 105: Alternating current switch-fuse combinations for rated voltages above 1 kV up to and including 52 kV
IEC 62271-200	High-voltage switchgear and controlgear - Part 200: AC metal-enclosed switchgear and controlgear for rated voltages above 1 kV and up to and including 52 kV
IEC 60529	Degrees of protection provided by enclosures (IP code)
Voltage detection system (VDS)	IEC 61243-5
Voltage presence indication systems (VPIS)	IEC 62271-206
Bushings	IEC 60137, CENELEC EN 50180 / EN 50181, EDF HN 52-S-61
Electronic protection relays	IEC 60255
Instrument transformers	IEC 61869-1; Part 1: General requirements
Instrument transformers	IEC 61869-2; Part 2: Additional requirements for current transformers
Instrument transformers	IEC 61869-3; Part 3: Additional requirements for inductive voltage transformers
Current sensors	IEC 60044-8; Part 8: Electronic current transformers
Voltage sensors	IEC 60044-7; Part 7: Electronic voltage transformers
Combined bushings sensors	IEC 60044-7, IEC 60044-8, CENELEC EN 50181, IEC 62271-206, IEC 61243-5
High-voltage fuses	IEC 60282-1; Part 1: Current-limiting fuses
Cable connection	IEC 60502-4, IEC 60137, CENELEC EN 50180, CENELEC EN 50181

33.1 Technical data - SafeRing

SafeRing - ring main unit, electrical data						
1	Rated voltage	Ur	kV	12	17.5	24
2	Rated power frequency withstand voltage	Ud	kV	28 ⁴⁾	38	50
	- across disconnecter		kV	32	45	60
3	Rated lightning impulse withstand voltage	Up	kV	95	95	125
	- across disconnecter		kV	110	110	145
4	Rated frequency ⁵⁾	fr	Hz	50/60	50/60	50/60
5	Rated normal current (busbars)	Ir	A	630	630	630
6	Rated normal current (cable switch)	Ir	A	630	630	630
7	Rated normal current (switch-fuse-disconnector)	Ir	A	200 ¹⁾	200 ¹⁾	200 ¹⁾
8	Rated normal current (vacuum circuit-breaker)	Ir	A	200	200	200
9	Rated short-time withstand current	Ik	kA	21 ³⁾	16 ³⁾	16 ³⁾
10	Rated duration of short-circuit	tk	s	3	3	3
11	Rated peak withstand current	Ip	kA	52.5	40	40
12	Internal arc classification IAC AFL	Iac	kA/s	20/1	20/1	20/1
13	Internal arc classification IAC AFLR	Iac	kA/s	20/1	20/1	20/1
14	Loss of service continuity			LSC2-PM, F-module LSC2A-PI		
Making and breaking capacities C-module:						
15	Rated mainly active load breaking current	Iload	A	630	630	630
16	Number of operations for mainly active load breaking	n		100	100	100
17	Rated distribution line closed-loop breaking current	Iloop	A	650	650	650
18	Rated single capacitor bank breaking current	I _{sb}	A	135	135	135
19	Rated earth-fault breaking current	I _{ef1}	A	205	160	160
20	Rated cable- and line-charging breaking current under earth-fault conditions	I _{ef2}	A	117	91	91
21	Rated short-circuit making current	I _{ma}	kA	52.5	40	40
22	Cable charging capacity	I _{cc2}	A	65	52	52
23	Line charging capacity	I _{lc}	A	1	1	1.5
24	Electrical and mechanical classes			E3, C2, M1		
Making and breaking capacities F-module:						
25	Rated making capacity ²⁾	I _{ma}	kA	21	16	16
26	Rated making capacity (downstream earthing switch)	I _{ma}	kA	12.5	12.5	12.5
27	Rated short-time current (downstream earthing switch)	Ik	kA	5	5	5
28	Rated duration of short-circuit	tk	s	1	1	1
29	Electrical and mechanical classes			E3, M1		
Making and breaking capacities V-module:						
30	Rated short-circuit breaking current	I _{sc}	kA	16	16	16
31	Rated cable-charging breaking current	I _c	A	31.5	31.5	31.5
32	Rated short-time current (earthing switch)	Ik	kA	16	16	16
33	Rated short-circuit making current (earthing switch)	I _{ma}	kA	40	40	40
34	Electrical and mechanical classes			E2, C2, S1, M1		

¹⁾ T-off fuse module: depending on the current rating of the fuse

²⁾ T-off fuse module: limited by high voltage fuse-links

³⁾ Valid with Interface C bushings (bolted type) only

⁴⁾ GOST version is available with 42kV power frequency withstand voltage

⁵⁾ De-rating for current parameters needs to be applied for 60Hz

33.2 Technical data - SafePlus

SafePlus - compact switchgear, electrical data						
1	Rated voltage	Ur	kV	12	17.5	24
2	Rated power frequency withstand voltage	Ud	kV	28 ⁶⁾	38	50
	- across disconnecter		kV	32	45	60
3	Rated lightning impulse withstand voltage	Up	kV	95	95	125
	- across disconnecter		kV	110	110	145
4	Rated frequency ⁸⁾	fr	Hz	50/60	50/60	50/60
5	Rated normal current (busbars)	Ir	A	630	630	630
6	Rated normal current (external busbars)	Ir	A	1250	1250	1250
7	Rated normal current (cable switch)	Ir	A	630	630	630
8	Rated normal current (switch-fuse-disconnector) ¹⁾	Ir	A	200	200	200
9	Rated normal current (vacuum circuit-breaker) ³⁾	Ir	A	630	630	630
10	Rated short-time withstand current ^{3) 7)}	Ik	kA	25	21	21
11	Rated duration of short-circuit	tk	s	3	3	3
12	Rated peak withstand current	Ip	kA	62.5	52.5	52.5
13	Internal arc classification IAC AFL	Iac	kA/s	20/1	20/1	20/1
14	Internal arc classification IAC AFLR	Iac	kA/s	25/1	25/1	25/1
15	Loss of service continuity			LSC2-PM, F-Module LSC2A-PI, M-module LSC2B-PM ¹⁰⁾		
Making and breaking capacities C-module:						
16	Rated mainly active load breaking current	Iload	A	630	630	630
17	Number of operations for mainly active load breaking	n		100	100	100
18	Rated distribution line closed-loop breaking current	Iloop	A	650	650	650
19	Rated single capacitor bank breaking current	I _{sb}	A	135	135	135
20	Rated earth-fault breaking current	I _{ef1}	A	205	160	160
21	Rated cable- and line-charging breaking current under earth-fault conditions	I _{ef2}	A	117	91	91
22	Rated short-circuit making current	I _{ma}	kA	62.5	52.5	52.5
23	Cable charging capacity	I _{cc2}	A	65	52	52
24	Line charging capacity	I _{lc}	A	1	1	1.5
25	Electrical and mechanical classes			E3, C2, M1		
Making and breaking capacities F-module:						
26	Rated making capacity ²⁾	I _{ma}	kA	25	20	20
27	Rated making capacity (downstream earthing switch)	I _{ma}	kA	12.5	12.5	12.5
28	Rated short-time current (downstream earthing switch)	Ik	kA	5	5	5
29	Rated duration of short-circuit	tk	s	1	1	1
30	Electrical and mechanical classes			E3, M1		
Making and breaking capacities V-module:						
31	Rated mainly active load breaking current ³⁾	I _l	A	630	630	630
32	Rated short-circuit breaking current	I _{sc}	kA	21	16	16
33	Rated cable-charging breaking current	I _c	A	31.5	31.5	31.5
34	Rated short-time current (earthing switch)	Ik	kA	21	16	16
35	Rated short-circuit making current (earthing switch)	I _{ma}	kA	52.5	40	40
36	Electrical and mechanical classes			E2, C2, S1, M1		
Making and breaking capacities V20-, V25-module:						
37	Rated mainly active load breaking current ³⁾	I _l	A	630	630	630
38	Rated short-circuit breaking current	I _{sc}	kA	25	20	20
39	Rated cable-charging breaking current	I _c	A	31.5	31.5	31.5
40	Rated short-time current (earthing switch)	Ik	kA	25	21	21
41	Rated short-circuit making current (earthing switch)	I _{ma}	kA	62.5	52.5	52.5
42	Electrical and mechanical classes			E2, C2, S1, M1		
Making and breaking capacities CB-module:						
43	Rated mainly active load breaking current ³⁾	I _l	A	630/1250	630/1250	630/1250
44	Rated short-circuit breaking current	I _{sc}	kA	25	20	20
45	Making capacity	I _{ma}	kA	62.5	50	50
46	Rated short-time current	Ik	kA	25	20	20
47	Electrical and mechanical classes			E2, C2, M2		

33.3 Technical data - general

Normal service conditions for indoor switchgear according to IEC 62271-200				
48	Ambient temperature ⁴⁾			
49	Maximum value	°C	+40	+40
50	Maximum value of 24 hours mean	°C	+35	+35
51	Minimum value ⁹⁾	°C	-25	-25
52	Altitude for installation above sea level ⁵⁾	m	1500	1500
53	Relative humidity max. 24 hour mean		95%	95%

¹⁾ T-off fuse module: depending on the current rating of the fuse

²⁾ T-off fuse module: limited by high voltage fuse-links

³⁾ Valid with Interface C bushings (400 series bolted type) only

⁴⁾ De-rating allows for higher maximum temperature

⁵⁾ For installation above 1500 m, reduced gas pressure is required

⁶⁾ GOST version is available with 42kV power frequency withstand voltage

⁷⁾ Duration and time can vary based on type of modules used in CSG

⁸⁾ De-rating for current parameters needs to be applied for 60Hz

⁹⁾ Lower temperature available upon request

¹⁰⁾ LSC 1 in case module is connected at least on one side directly to the busbars

General data, enclosure and dimensions

1	Type of ring main unit SafeRing and compact switchgear SafePlus	Metal-enclosed switchgear and controlgear according to IEC 62271-200		
2	Number of phases	3		
3	Type-tested RMU and CSG	Yes		
4	Pressure test on equipment tank or containers	2.64 bar abs		
5	Facility provided with pressure relief	Yes		
6	Insulating gas	SF ₆		
7	Nominal operating gas pressure	1.4 bar abs 20°C		
8	Rated filling level for insulation P _{re}	1.4 bar		
9	Minimum functional level of insulation P _{me}	1.3 bar		
10	Gas leakage rate / annum	< 0.1%		
11	Expected operating lifetime	30 years		
12	Facilities provided for gas monitoring ¹⁾	Yes, temperature compensated manometer can be delivered		
13	Material used in tank construction	Stainless steel sheet, 2.5 mm		
14	Busbars	240 mm ² Cu		
15	Earth bar (external)	100 mm ² Cu		
16	Earth bar bolt dimension	M10		
	Overall dimensions of the fully assembled RMU	Height mm	Depth mm	Width mm
17	2-way unit	1336	751	695
18	3-way unit	1336	751	1020
19	4-way unit	1336	751	1345
	CSG (2, 3 and 4 way units as RMU) with additional height for optional low voltage compartment (470 mm)			
20	1-way unit	1336	751	370
21	5-way unit	1336	751	1670
22	Distance between units when external extension is used	8 mm		
23	Distance between units when side extension is used	14 mm		

¹⁾ Manometer with INO or INO/INC upon request

Weight table			
Maximum weights for standard SafeRing			
2-way DeV	300 kg	2-way DeF	300 kg
3-way CCV	450 kg	3-way CCF	450 kg
4-way CCCV	600 kg	4-way CCCF	600 kg
4-way CCVV	600 kg	4-way CCFV	600 kg
3-way CCC	450 kg		
4-way CCCC	600 kg		
SafePlus			
Standard 1-way		150 kg	
2-, 3- and 4-way		as for SafeRing	
5-way		750 kg	
M - metering module incl. transformers		250 kg	
Mt - metering tariff module incl. transformers		350 kg	
CB - module incl. low voltage compartment		410kg	

Operations, degree of protection and colors		
1	Means of switch operation	separate handle
2	Means of fuse-switch/circuit-breaker operation	separate handle and push buttons
3	Rated operating sequence of circuit-breaker (V-module)	O – 3 min – CO – 3 min – CO
4	Rated operating sequence of circuit-breaker (CB-module)	O – 0.3 s – CO – 15s – CO
5	Total opening time of circuit-breaker	approx. 75 ms
6	Closing time of circuit-breaker	approx. 40 – 60 ms
7	Mechanical operations of switch	1000 CO - class M1
8	Mechanical operations of earthing switch	1000 CO - class M1
9	Mechanical operations of circuit-breaker (V-module)	2000 CO - class M1
10	Mechanical operations of circuit-breaker (CB-module)	30000 CO - class M3
11	Principle switch-disconnector and earthing switch	3 position combined switch-disconnector and earthing switch
Load break switch:		
12	Rated operations on short circuit current (class E3)	5 - class E3
13	Rated operations mainly active load (class E3)	100 - class E3
Degree of protection:		
14	High voltage live parts, SF ₆ gas tank	IP 67
15	Front cover mechanism	IP 2XC
16	Cable covers	IP 3X
17	Protection class of fuse compartment	IP 67
18	Low voltage compartment	IP 2XC (IP22 on request)
Colors:		
18	Front covers	RAL 7035
19	Side and cable covers	RAL 7035

Fuses, cable compartment		
1	Standard fuse-link length	442 mm. Shorter fuse-links can be used with fuse adapter
2	Standard dimensions	According to DIN 43625
3	Maximum size 12kV	125 A
4	Maximum size 24kV	63 A
Cable box for heat shrinkable termination:		
5	Phase to phase clearance	107 mm
6	Phase to earth clearance	54.5 mm
7	Phase to earth over insulator surface (creepage)	120 mm
8	Type of cable termination adapters	Elbow or T-connector

33.4 Technical data - number of operations

SafeRing/SafePlus C-module - 12, 15, 17.5 and 24kV

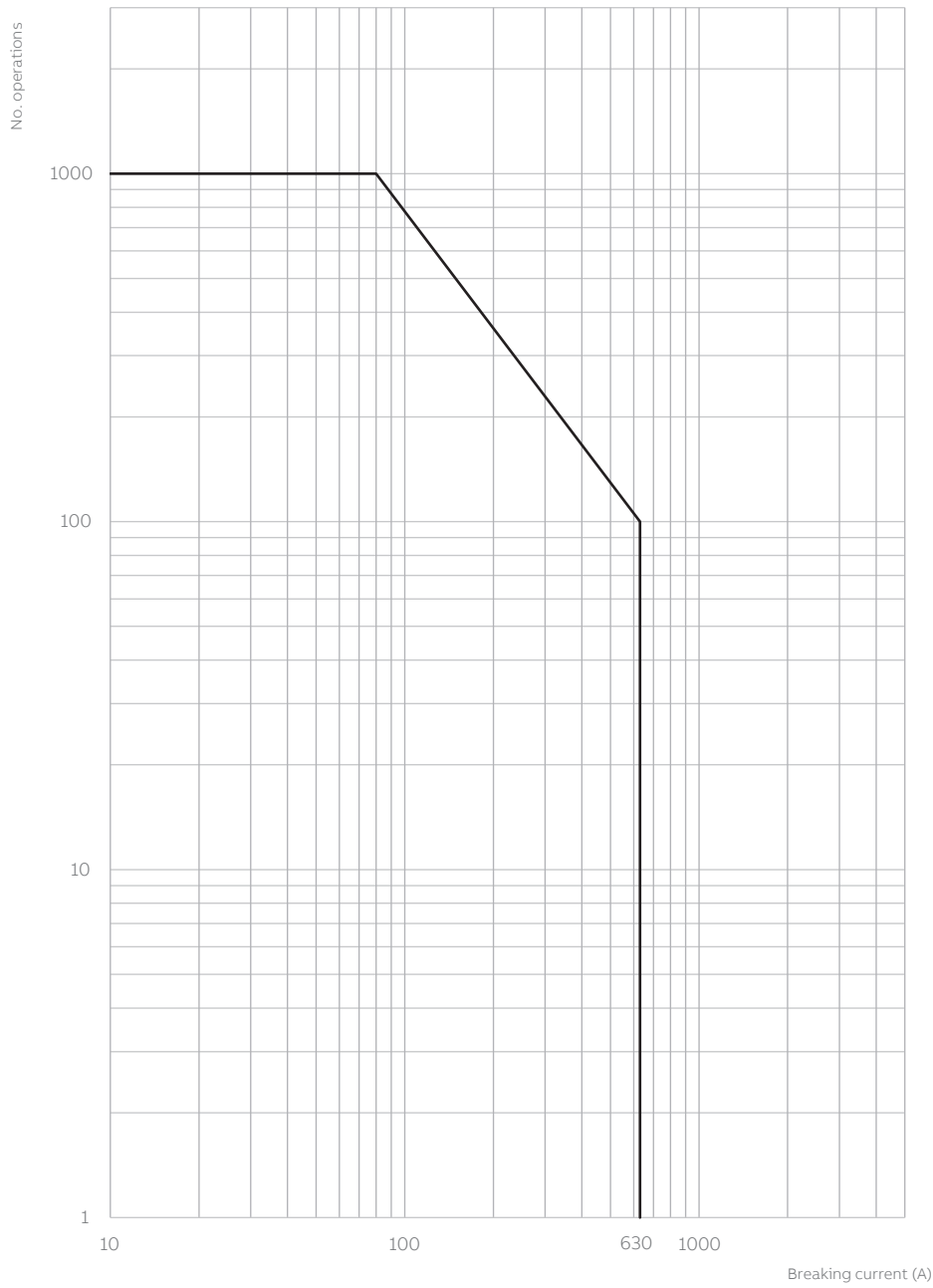

SafeRing V-module - 12, 15, 17.5 and 24kV (VG5)

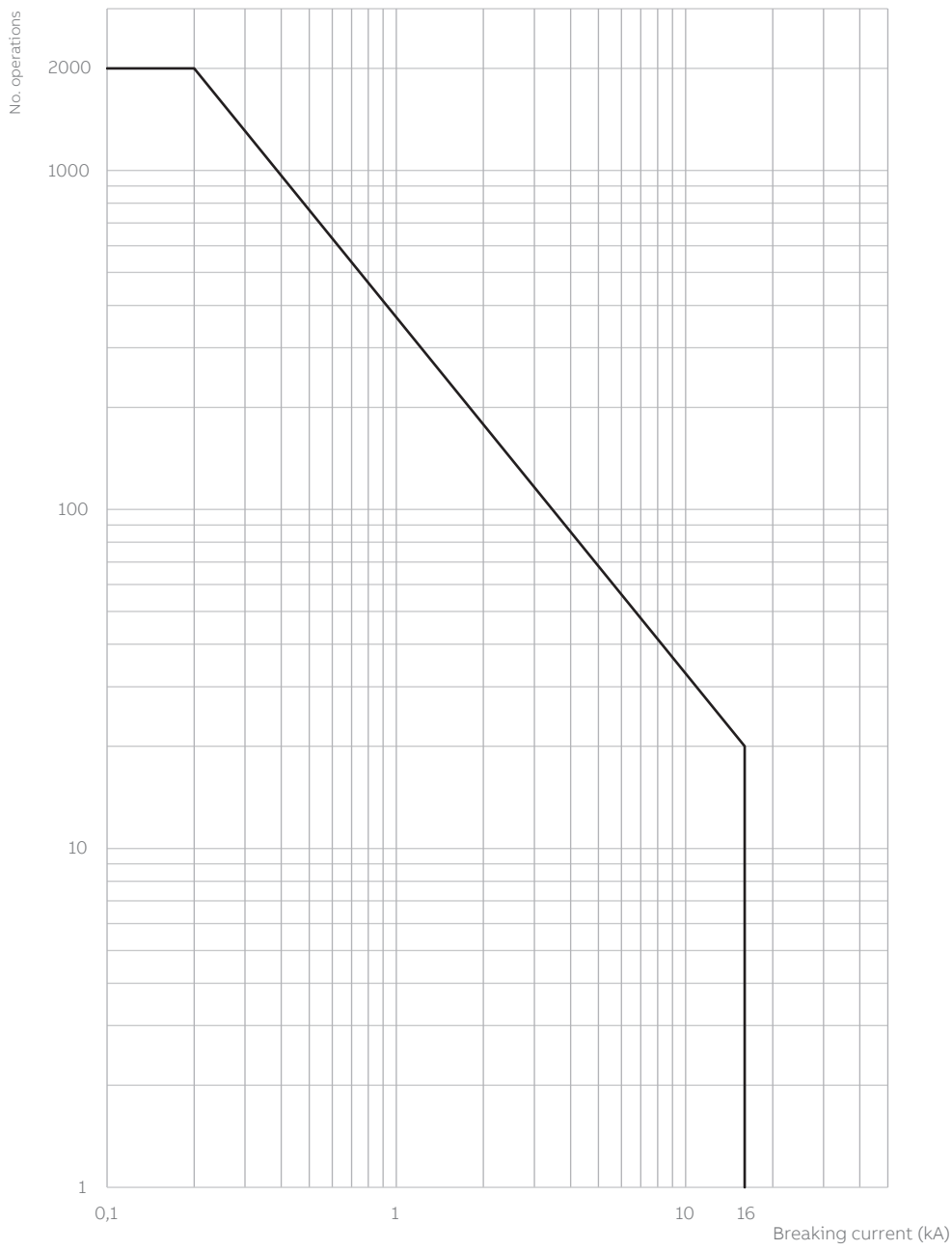

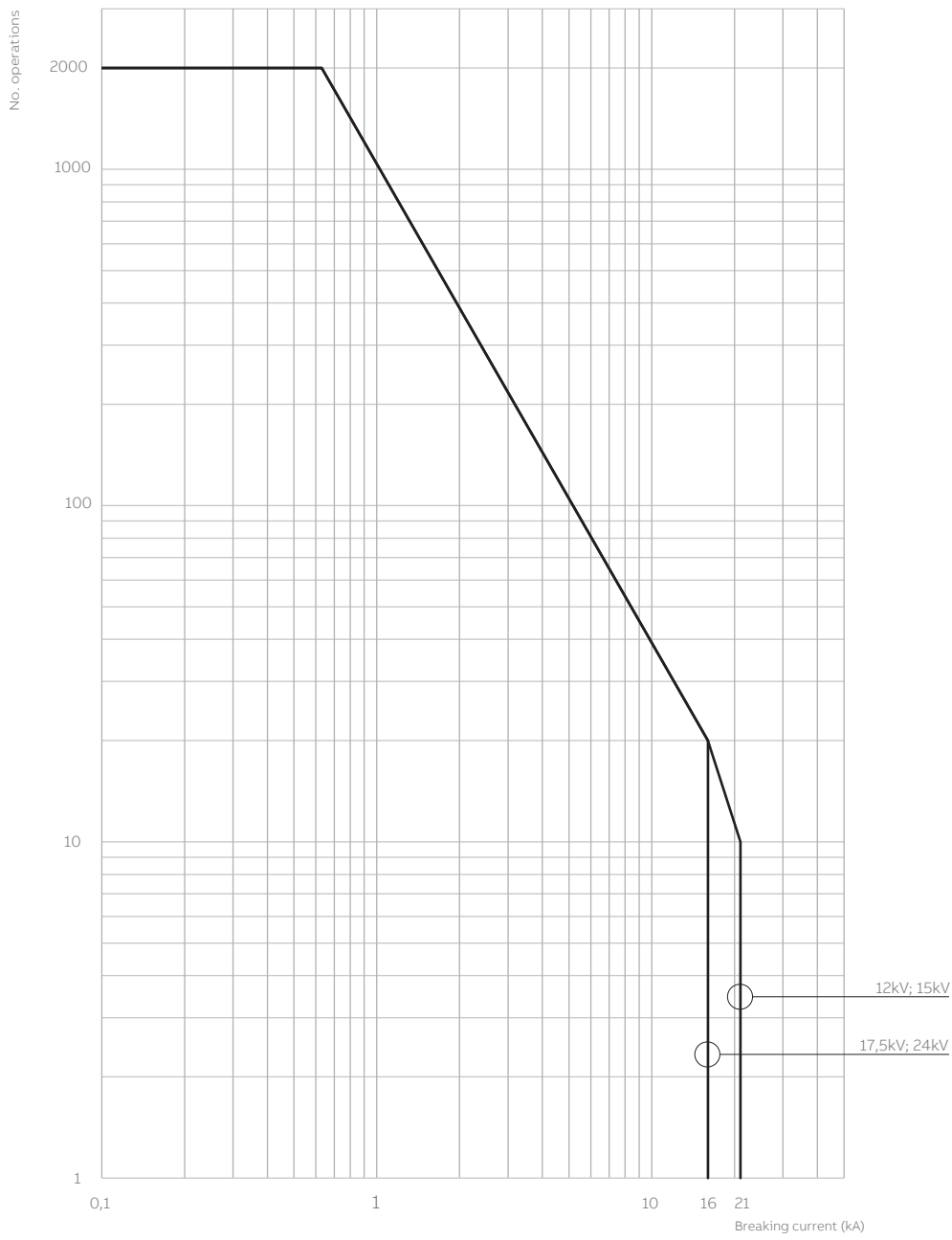
SafePlus V-module - 12, 15, 17.5 and 24kV (VG5)

SafePlus V25 High duty - 12kV (VG4 - M1/M2)

SafePlus V25 High duty - 15, 17.5 and 24kV (VG4 - M1/M2)

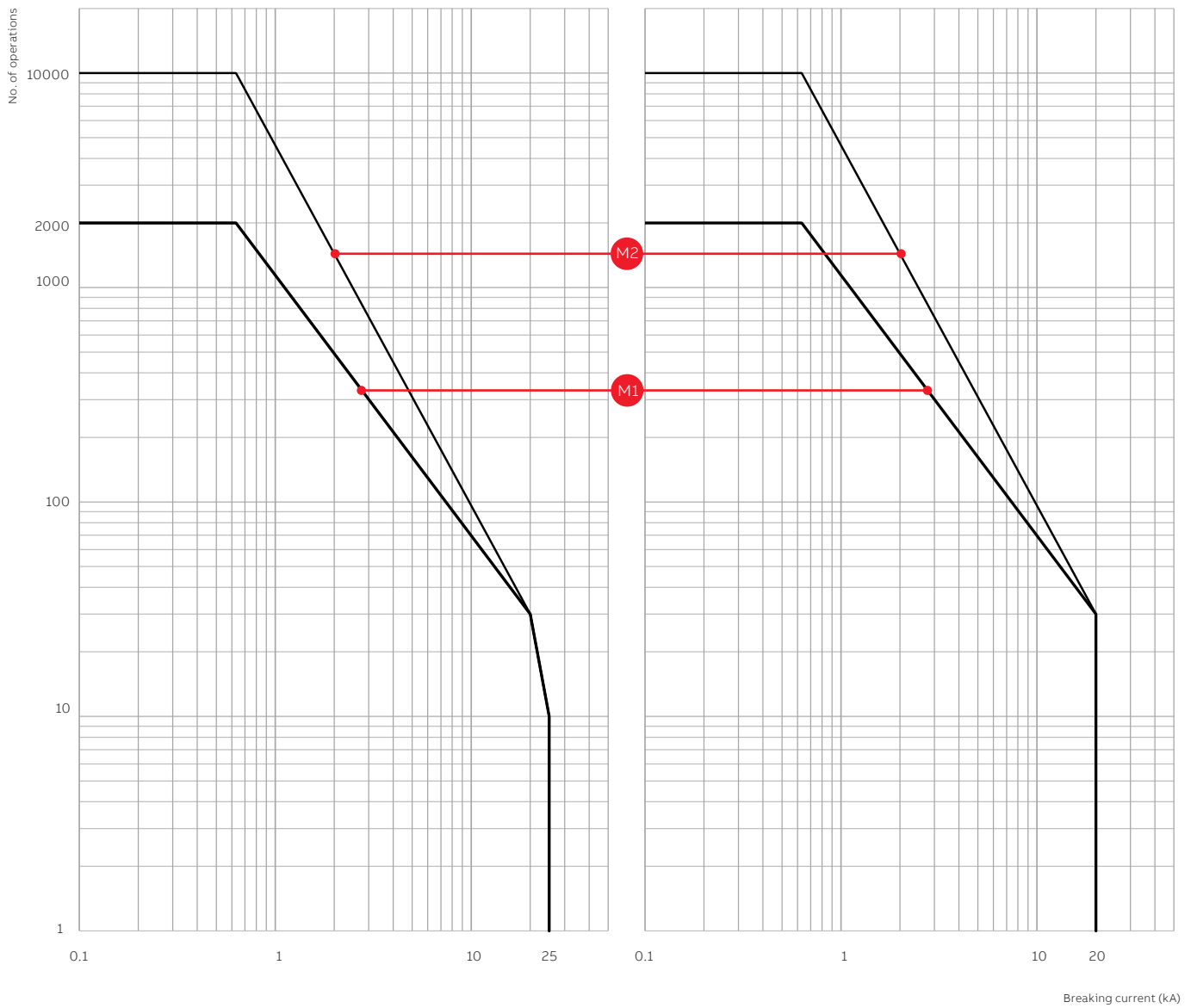

VD40 X0 - 20kA

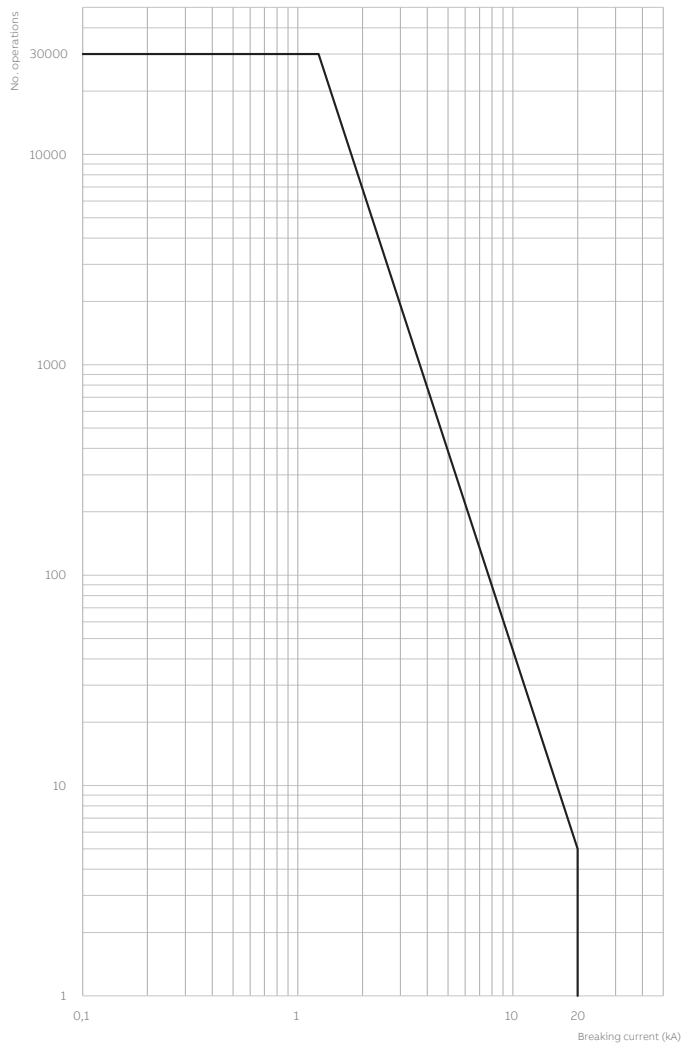

VD40 X0 - 25kA

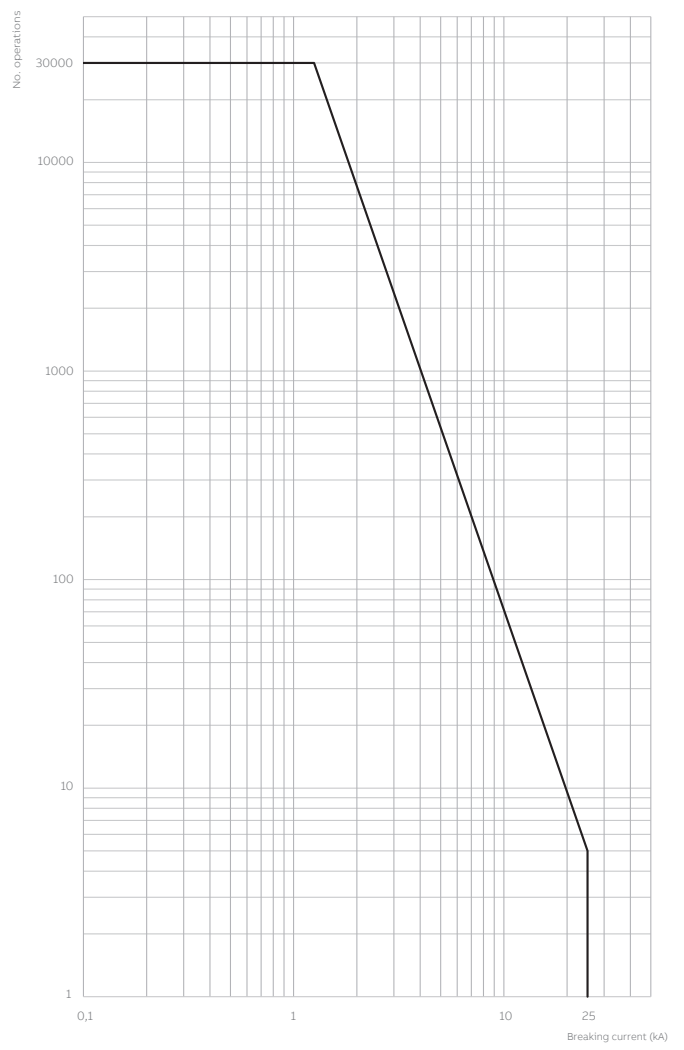

34 Environmental certification

Life expectancy of product

The product is in compliance with the requirements denoted by IEC 62271-200. The design incorporates a life span under normal “indoor service conditions” (IEC 62271-1 Cl. 4.1). The switchgear is gas tight and classified as “sealed pressure system”* with an expected operating life exceeding 30 years and a leakage rate of less than 0.1 % per year (IEC 62271-1 Cl. 6.16). Referring to the filling pressure of 1.4 bar, the switchgear will maintain gas tightness and a gas pressure better than 1.35 bar throughout its operating life.

Recycling capability

Raw Material	CCF		CCV		Recycle	Environmental effects & recycle/reuse processes
	Weight (kg)	% of total weight	Weight (kg)	% of total weight		
Iron	132.80	41.5	132.24	46.7	Yes	Separate, utilize in favour of new source (ore)
Stainless steel	83.20	26.0	73.94	25.0	Yes	Separate, utilize in favour of new source (ore)
Copper	43.98	13.7	44.40	15.0	Yes	Separate, utilize in favour of new source (ore)
Brass	2.30	0.7	1.74	0.6	Yes	Separate, utilize in favour of new source (ore)
Aluminium	8.55	2.7	7.83	2.6	Yes	Separate, utilize in favour of new source (ore)
Zinc	3.90	1.2	1.45	0.5	Yes	Separate, utilize in favour of new source (ore)
Silver	0.08	0.0	0,08	0.0	Yes	Electrolysis, utilize in favour of new source
Thermoplastic	5.07	1.6	12	4.0	Yes	Alternatively sort by sort, granulate, re-use or apply as energy additive in refuse incineration
Dielectric coil	0.21	0.1	0	0.0	Yes	Reclaim or use as high-grade energy additive in refuse incineration
SF ₆ gas	3.09	1.0	3.20	1,1	Yes	ABB Power Technology in Skien recovers used SF ₆ gas
Total recyclables	283.18	88.4	282.88	95.5		
Epoxy incl. 60% quartz	26.75	8.4	7.42	2.5	No	
Rubber	1.35	0.4	0.14	0.0	No	
Not specified ^{*)}	9.00	2.8	5.87	2.0		
Total weight ^{**)}	320.28	100 %	320.28	100 %		
Packing foil	0.20		0.20		Yes	High-grade energy additive in refuse incineration
Wooden pallet	21.50		21.50		Yes	Re-use of use as energy additive in refuse incineration

*) Not specified amount represents: Stickers, film-foils, powder coating, screws, nuts, tiny components, grease, depending on configuration.

**) All figures are collected from 3-way module with arc suppressor.

End-of-life

ABB Electrification Products Division is committed to the protection of the environment and follows the ISO 14001 standard. It is our obligation to assure environmentally clean processes, high recyclability and facilitate end-of-life recycling for our products. The switchgear contains SF₆ gas with a high global warming potential and the gas must not be released to the atmosphere. The switchgear is marked with a SF₆ Global Warming label.

ABB's handling and recycling services are in accordance with IEC 62271-4 for end of life of SF₆ filled equipment. ABB Electrification, Distribution Solutions unit in Skien is equipped for the recovery of SF₆ gas from discarded switchgears.



ABB Electrification AS

Distribution Solutions
P.O.Box 108, Sentrum
N-3701 Skien, Norway
Phone: +47 35 58 20 00

www.abb.com/medium-voltage