

E-Series Three-Phase Recloser with ADVC Controller

Medium Voltage Distribution Whitepaper

01/2019

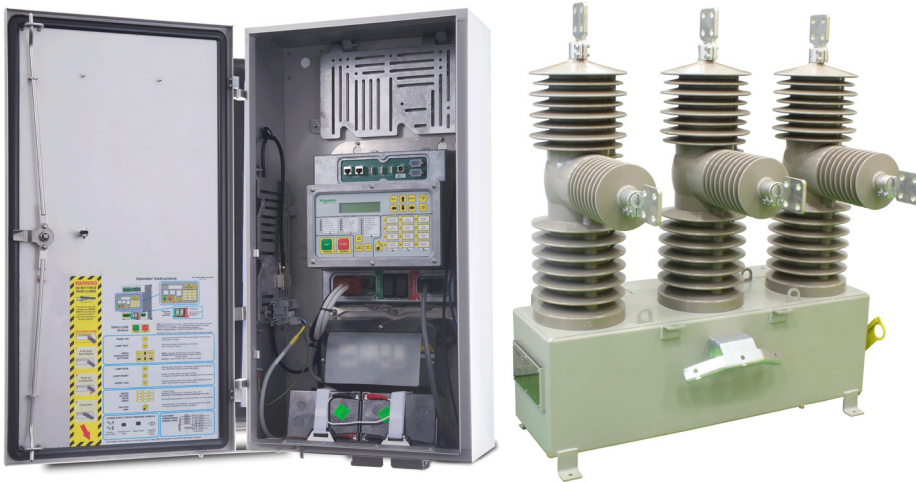

Well-being Performance

- RoHS Compliant
- SVHC Free
- SF6 Free

Circular Performance

- 60% Recyclable
- End of Life Instructions
- Maintenance Free

Resource Performance

- Optimized Energy Performance
- Reduced CO2 Emissions
- PEP (Product Environmental Profile) Ecopassport Declaration

Schneider Electric's ecoDesign Way program was reviewed and validated by UL Environment to meet the requirements of the ANSI / IEC 62430

The information provided in this documentation contains general descriptions and/or technical characteristics of the performance of the products contained herein. This documentation is not intended as a substitute for and is not to be used for determining suitability or reliability of these products for specific user applications. It is the duty of any such user or integrator to perform the appropriate and complete risk analysis, evaluation and testing of the products with respect to the relevant specific application or use thereof. Neither Schneider Electric nor any of its affiliates or subsidiaries shall be responsible or liable for misuse of the information contained herein. If you have any suggestions for improvements or amendments or have found errors in this publication, please notify us.

No part of this document may be reproduced in any form or by any means, electronic or mechanical, including photocopying, without express written permission of Schneider Electric.

All pertinent state, regional, and local safety regulations must be observed when installing and using this product. For reasons of safety and to help ensure compliance with documented system data, only the manufacturer should perform repairs to components.

When devices are used for applications with technical safety requirements, the relevant instructions must be followed.

Failure to use Schneider Electric software or approved software with our hardware products may result in injury, harm, or improper operating results.

Failure to observe this information can result in injury or equipment damage.

© 2019 Schneider Electric. All rights reserved.

Table of Contents



	About the Book	5
Chapter 1	Introduction	7
	Executive Summary	8
	Introduction and Benefits	9
	Applications	10
Chapter 2	ACR Overview	11
	ACR Overview	12
	E-Series Recloser Specifications	14
Chapter 3	ADVC Controller Series	15
	ADVC Controller Series	16
	ADVC Features	18
	<i>flexVUE</i> Operator Interface	20
Chapter 4	Switchgear Operating System software	23
	WSOS	23
Chapter 5	Other Features	27
	General Protection Features	28
	Advanced Protection Features	31
	Measurement Features	33
	Pole Mounting Details	35
Appendices	39
Appendix A	Required details for order	41
	ADVC Controller	42
	Required Details for Order	43

About the Book



At a Glance

Document Scope

This document promotes or highlights the features of the E-Series recloser ranges with ADVC Controller range. It also describes a brief overview of the technical specifications of the E-Series recloser range, the ADVC Controller and the Software WSOS 5.

Validity Note

This document is valid for E-Series remotely controlled and monitored automatic circuit recloser (ACR) which consists of a E-Series automatic circuit recloser (ACR) combined with an ADVC Controller (ADVC).

Related Documents

Title of Documentation	Reference Number
E-Series Installation Manual	N00-807 - Revision 1
ADVC Controller Operational Manual	N00-812 - Revision 1

You can download these technical publications and other technical information from our website at <https://www.schneider-electric.com/en/download>

Trademark Notice

All trademarks are owned by Schneider Electric Industries SAS or its affiliated companies.

Chapter 1

Introduction

What Is in This Chapter?

This chapter contains the following topics:

Topic	Page
Executive Summary	8
Introduction and Benefits	9
Applications	10

Executive Summary

In the past, distribution equipment such as reclosers have been purchased only to support load growth. Today your customers and the electricity consumers, are demanding reduced outages and lower tariffs. At Schneider Electric, we are continually working to provide the advanced equipment needed for tomorrow's competitive electricity distribution system.

By using our technologically advanced equipment, operating costs are reduced and capital works can be deferred through better management of existing plant. In addition, outages causing lost revenue is reduced.

In addition to automatic circuit reclosers, the Schneider Electric family of switchgear includes remotely controlled and monitored pole-mounted load break switches and sectionalisers, as well as remote control and monitoring software.

The Schneider Electric Switchgear and controller product family is a complete solution for Distribution System Automation.

Introduction and Benefits

Overview

The E-Series solid dielectric Automatic Circuit Recloser (ACR) represents Schneider Electric's commitment to improved products and ongoing product development. Providing the features of a traditional recloser, plus the benefits of up-to-date design optimized for automation, remote control and monitoring, now or in the future.

The E-Series development was driven by customer demand for improved return on capital investment in the distribution network. After careful evaluation of customers' needs, the E-Series was developed to achieve performance using technology in solid dielectrics, vacuum interruption and microelectronics.

Benefits

Reduced Purchase Costs

- No requirement for additional RTU, power supplies, batteries, or enclosures. The Remote Terminal Unit (RTU) and a range of communication ports are included in the standard equipment.

Reduced Installation Costs

- Simple Commissioning: Configuration of the unit is from the WSOS Software or the Operator Interface (O.I.).
- The key components required for installation are included.
- Pole mounting brackets are provided. An optional Voltage Transformer (VT) for auxiliary supply is available.
- Schneider Electric ACRs are suitable for low-cost feeder circuit breakers in outdoor primary substations. In this application, connection into the substation control system is simple and low cost.

Reduced Operating Costs

- Reduce Equipment Damage: The integral protection relay provides fast isolation of any event.
- The recloser monitors line current and voltage without the need for additional measurement devices. This data can then be used for forward planning and optimization of existing feeders.
- Long lifetime, low maintenance equipment reduces lifetime cost.

DSA/SCADA Compatibility

When used with a compatible Distribution System Automation (DSA) or SCADA system, Schneider Electric ACRs support remote control and monitoring to provide the following advantages

- Reduced Travel Time for Line Crews: Information on events current and recloser status values transmitted to system control allows fast location of the by affected line section.
- This same information allows informed remote switching, reducing the affected area and quickly restoring supply.
- ACRs can be configured and settings managed from system control, without technicians having to visit each individual recloser in the field, with a consequent reduction in traveling time and improved system integrity.

Applications

Smart Grid Ready

With the increasing push for advanced monitoring, reduction of outages and the need to facilitate two-way communications between supply and the distribution network, the E-Series solid dielectric recloser is ready to be integrated into your Smart Grid solution.

Loop Automation

Restoring supply to your customers in time is the focus of Recloser Solutions' Loop Automation Scheme. The Loop Automation Scheme reconfigures protection settings, sectionalises by events, minimizes affected areas, and restores network supply without the need for communications or operator intervention, using standard recloser features.

A network affected by an outage is automatically reconfigured to provide power to the unaffected area when an additional supply is available. Using a combination of Feeder, Mid-Point and Tie Reclosers to protect, sectionalise by events and minimize affected areas. Loop Automation is a Distribution System Automation Scheme designed to restore supply to customers in time.

Automatic Changeover (ACO)

The Automatic Changeover (ACO) system uses primary & alternative supplies, master & slave reclosers and fast communications so the supply is available for a load in the event of a power outage.

Using a number of different set-ups, including Break-Before-Make and Make-Before-Break, allows the system to be configured to the specifications required for the load. The system can even be set up for one-way or two-way switching so the power is available to your systems.

Operation as a Sectionalizer

Reclosers and sectionalizers work together to further improve feeder reliability. Using a separate RL-Series LBS/ Sectionalizer, as part of a feeder automation network, detects passage event and automatically isolates sections events of a network in conjunction with upstream recloser operation.

To accomplish this it senses the three-phase current and voltage to count the number of recloser trip operations. When the pre-programmed number of recloser operations is reached, the controller opens the sectionalizer during the recloser downtime to isolate the downstream event.

Chapter 2

ACR Overview

What Is in This Chapter?

This chapter contains the following topics:

Topic	Page
ACR Overview	12
E-Series Recloser Specifications	14

ACR Overview

E-Series Overview

The E-Series circuit breaker is controlled and monitored by either the **COMPACT** or **ULTRA** ADVC Controller (ADVC).

Enclosed in a 304 (**COMPACT**) or 316 (**ULTRA**) grade stainless steel enclosure the ADVC provides an electronic controller with Operator Interface (O.I.) that monitors the circuit breaker and provides protection, measurement, control, and communication functions. Connected via a control cable, the switchgear and ADVC can form a remotely controlled and monitored ACR.

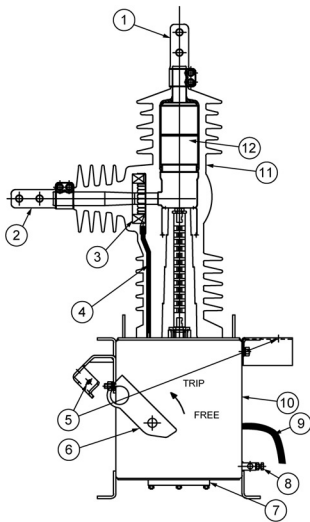

Cross section of E series 27 kV switchgear

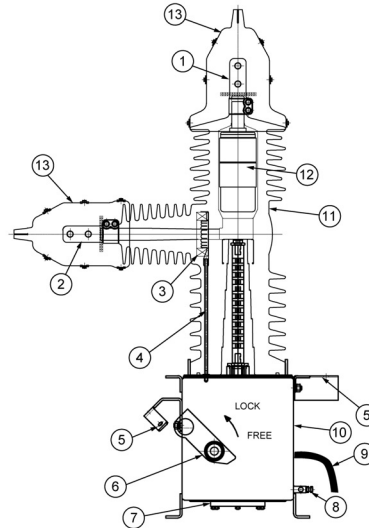

Cross section of E series 38 kV switchgear

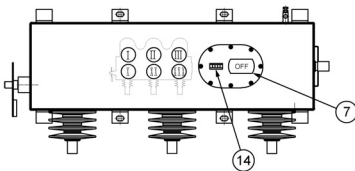

Typical bottom view of E series 27 kV/38 kV switchgear

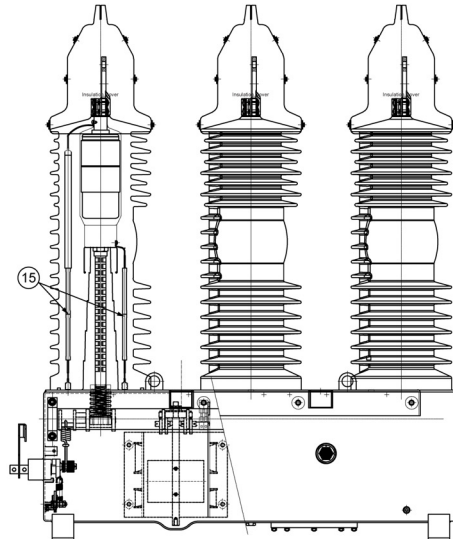

Typical front view of E series 27 kV/38 kV switchgear

- 1 X-side terminal
- 2 I-side terminal
- 3 Current transformer
- 4 CT wiring
- 5 Lightning arrester brackets
- 6 Manual trip ring
- 7 On/Off indicator
- 8 Earthing point
- 9 Control cable
- 10 Stainless steel tank
- 11 Epoxy bushing
- 12 Vacuum interrupter
- 13 Bird Guard

- 14 Counter
- 15 Resistive voltage divider (RVD)

E-Series Function

The switchgear is operated by a magnetic actuator which produces an opening and closing action. Switching occurs when a controlled pulse is sent through the open/ close actuator from storage capacitors in the ADVC. When closed, the switch is latched magnetically. Spring loaded push-rods provide contact loading on the interrupters.

A Current Transformer (CT) and a Resistive Voltage Divider (RVD) are moulded into the epoxy-housing. These are monitored by the ADVC for protection, remote monitoring, and display. An auxiliary voltage supply of 115/230 V AC is required to power the control unit. Where this is inconvenient, an additional voltage transformer can be provided. The recloser is supplied with optional cable clamp connectors. Mounting brackets for lightning arresters are optionally available.

The switchgear contact position is shown by a large, clearly visible On/Off indicator. A hook-stick can be used to engage the manual trip ring to trip and lockout the recloser from the ground. The mechanical trip ring has two positions: UP position of the manual trip lever allows for normal operation, the DOWN position of the manual trip lever trips the recloser and further pulling it down locks the recloser both mechanically and electronically in open position.

E-Series Recloser Specifications

Description	Specification	Specification
E-Series Range	27 kV	38 kV
	12.5 kA	16 kA
RATINGS		
Rated Maximum Voltage	27 kV	38 kV
Rated Continuous Current	630 A	800 A
Fault Make Capacity (rms)	12.5 kA	16 kA
Fault Make Capacity (Peak)	32.5 kA	41.6 kA
Power Operating Time (Close/Open)	0.1/0.05 s	0.1/0.05 s
Mechanical Operations	10,000	10,000
Rated Full Load Operations	10,000	10,000
Short time Current	12.5 kA	16 kA
BREAKING CAPACITY		
Mainly Active (0.7pf)	630 A	800 A
Fault Break Capacity	12.5 kA	16 kA
Cable Charging	25 A	40 A
Line Charging	5 A	5 A
LIGHTNING IMPULSE WITHSTAND LEVEL		
Phase to Earth	150 kV	170 kV
Across Interrupter	150 kV	170 kV
POWER FREQUENCY WITHSTAND VOLTAGE		
Phase to Earth	60 kV	70 kV
Across Interrupter	60 kV	70 kV
SERVICE CONDITIONS		
Ambient Temperature ^a (°C)	-40–50	-40–50
Ambient Temperature ^a (°F)	-40–122	-40–122
Radiation (Max)	1.1 kW/m ²	1.1 kW/m ²
Humidity	0–100%	0–100%
Altitude meters (Max) ^b	3000	3000
Altitude feet (Max) ^b	9840	9840
NET WEIGHTS		
Circuit breaker with pole mount bracket (kg/lbs)	195/430	220/485
Control cubicle with control cable (kg/lbs)	41/90	41/90
Gross Weight of crate (kg/lbs)	275/600	360/794
CRATE DIMENSIONS		
Width (mm/in.)	1140/44.8	1140/44.8
Depth (mm/in.)	1080/42.5	1080/42.5
Height (mm/in.)	1140/44.8	1220/48
IEC and IEEE STANDARDS		
Applicable standards	IEC62271-111 and IEEE C37.60	IEC62271-111 and IEEE C37.60

Chapter 3

ADVC Controller Series

What Is in This Chapter?

This chapter contains the following topics:

Topic	Page
ADVC Controller Series	16
ADVC Features	18
<i>flexVUE</i> Operator Interface	20

ADVC Controller Series

Overview

Advanced protection, data logging, and communications capabilities are made possible by the technology housed in the ADVC Controller.

It has been designed especially for outdoor pole mounted operation and is typically mounted low on the pole for ease of access by operation personnel.



ADVC ULTRA (with flexVUE)



ADVC COMPACT (with setVUE)

Function

With a cubicle designed to minimise temperature rise from solar heating, the 304 (**COMPACT**) or 316 (**ULTRA**) grade stainless steel enclosure is used to mount the Control And Protection Enclosure (CAPE), Power Supply Unit (PSU), customer accessories and Operator Interface.

The ADVC Controller Series incorporates the functions of a multi-function protection relay, a circuit breaker controller, a metering unit, and a remote terminal unit.

Batteries are carefully located underneath these modules to help avoid overheating so that a battery life of up to 5 years ⁽¹⁾ can be achieved. A vandal resistant lockable stainless steel door, sealed with a rubber gasket, provides access to the Operator Interface. Vents are screened against vermin entry and the electronic parts are enclosed in a sealed die-cast enclosure which help to protect them from entry of moisture and condensation for a long lifetime.

The **COMPACT** cubicle is suitable for temperatures from -10 to 50 °C, while the option of a battery heater in the **ULTRA** cubicle extends its operating temperature range from -40 to 50 °C.

A built-in microprocessor controlled power supply provides uninterrupted operation of not only the circuit breaker and controller, but also the communications radio or modem. These accessories are connected to a built-in user programmable radio power supply. Therefore no other power supplies are required for connection into your SCADA or Distribution Automation System.

Due to careful design the efficiency of the parts is high, allowing a battery hold up time of up to 48 hours ⁽²⁾. The architecture used has the advantage that the circuit breaker operation is independent of the high voltage supply, relying on a set of capacitors charged by the auxiliary supply.

Due to sophisticated power supply management techniques, a circuit breaker operation will operate when attempted and alarms are raised over the telemetry when auxiliary power is lost.

Communications equipment can be mounted within the ADVC Controller cubicle. RS-232 and Ethernet TCP/IP are provided as standard to support the of your communications needs.

The ADVC Controller series is available in two models:

- **ULTRA**
- **COMPACT**

The following table outlines some of the differences between the two models:

	ULTRA	COMPACT
Enclosure	316 stainless steel	304 stainless steel
Door locking	Three-point	Two-point
Customer accessory tray	Side tray Upper tray	Side tray only
Input/Output modules	8 inputs, 8 outputs Optional	N/A
Battery heater	Optional	N/A
Battery	7 Ah or 12 Ah	7 Ah
Temperature range	-40–50 °C With battery heater option	-10–50 °C
Auxiliary power supply	115/230 Vac	115/230 Vac
Dual AC power supply	Optional	N/A
VT power via switchgear	Optional	Optional
DC power supply	Optional	N/A

- NOTE:** 1. Battery replacement interval is influenced by environmental temperature.
2. With optional 12 Ah battery, panel off and without communications devices operating.

ADVC Features

ADVC Block Diagram

Schneider Electric automatic circuit reclosers provide many outstanding advantages to the user.

New and innovative features have been made possible by the intimate way the pole-mounted circuit breaker and control cubicle work together. The ADVC block diagram shows how the two items are interfaced.

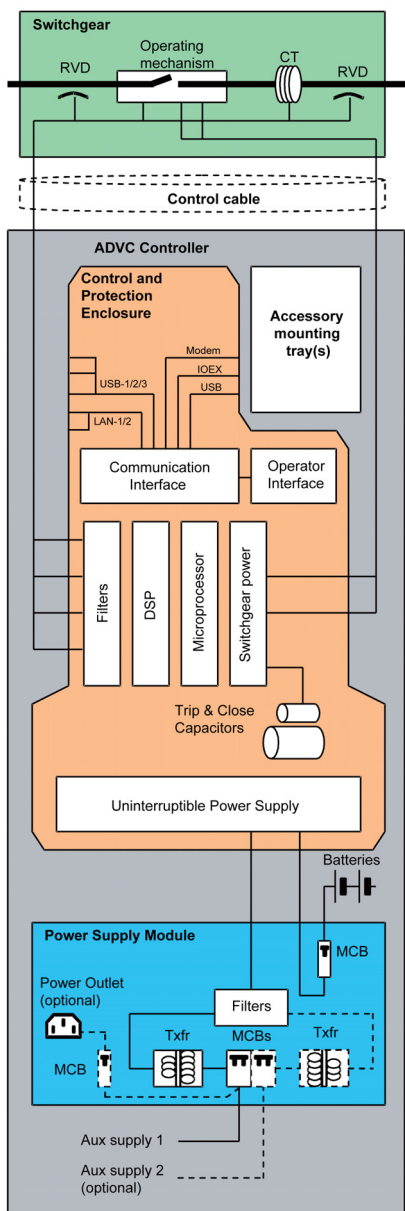

ADVC Controller block diagram

ADVC Features

Special extended range current transformers provide a range from 1 A –12,500 A for measurement and protection. Embedded voltage screens accurately image the primary voltage value and phase relationship at the analog front end, allowing measurement of voltage, current, power factor and frequency in the electronic module.

Two different Operator Interfaces are available, these are:

- **setVUE** Operator Interface
 - Based on the field-proven operator panels in the previous controllers, this menu-driven interface with large LCD display offers a familiar look and feel.

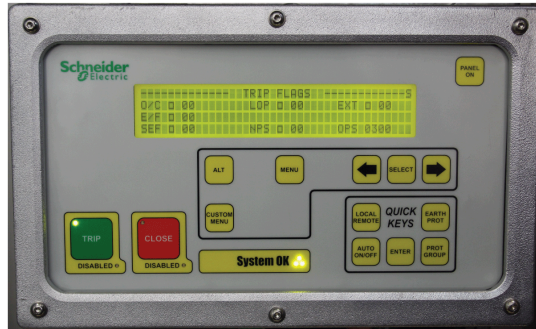

setVUE Operator Interface

- **flexVUE** Operator Interface
 - 20 Status Lamps provide a quick snapshot of the protection and controller status.
 - 12 Quick Action Keys are available to execute frequently used actions such as “Remote control” On/Off, “RECLOSE” On/Off, and so on. Each key has its own status lamp to indicate the On/Off state.
 - The Status Lamps and Quick Action Keys are customizable.
 - It is possible to access Event and Measurement data and modify settings.

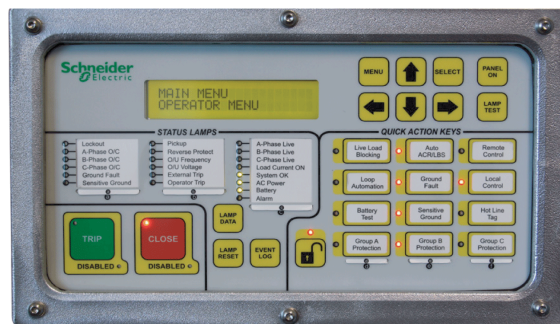

flexVUE Operator Interface

Telemetry Interface

The Schneider Electric ACR can be interfaced to your SCADA system through its RS-232 ports and a modem of your choice. Ethernet TCP/IP are also available. A variable voltage uninterrupted power supply is included for the radio or modem, which can be mounted inside the communications cubicle. Many telemetry protocols can be supported such as DNP3 and IEC 60870-5-101/104.

Computer Interface

WSOS is an advanced personal computer-based software package to allow off-line and on-line programming, monitoring, and control of a recloser via a USB port, RS232 port, or Ethernet.

Remote Control

The ADVC offers an impressive list of communication ports for use in remote control applications:

- 2 x RS-232
- 2 x 100Base-T Ethernet port
- 3 x USB (Type A)
- 1 x USB (Type B)

flexVUE Operator Interface

Overview

The flexVUE Operator Interface uses Light Emitting Diodes (Lamps) and an LCD display to communicate the system status to a local operator. Operator actions that are performed on a regular basis can be mapped to 12 dedicated buttons on the interface.

Each of these buttons also have a lamp to indicate the On/Off state of each action. Together with the 20 status lamps the panel provides no less than 32 three-color LEDs that display the state of the controller and overhead system. On the interface, the action buttons are grouped together and referred to as Quick Action Keys. The status LEDs are also grouped together and referred to as Status Lamps.

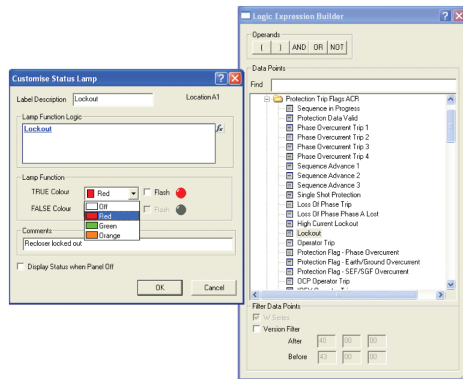

Example of building the logic function for a Status Lamp

Every controller is programmed with a standard configuration of Status Lamps and Quick Action Keys: text labels are used to mark the function of each. These labels are inserted into special pockets within the flexVUE Operator Interface and can be changed in the field if required.

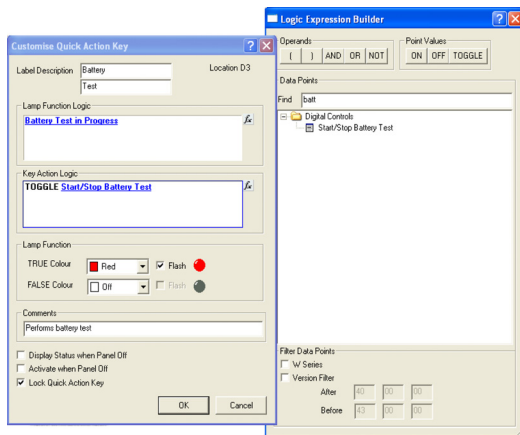

Example of setting the action keys

A graphical panel configuration tool is provided as part of the WSOS 5 software package that allows full customization of the *flexVUE* Operator Interface, if required. With the tool, you can create your own logic functions driving the Status Lamps, as well as modify the actions linked to each Quick Action Key. New labels can be printed from the WSOS template using standard office stationery, cut to size and inserted into the controller.

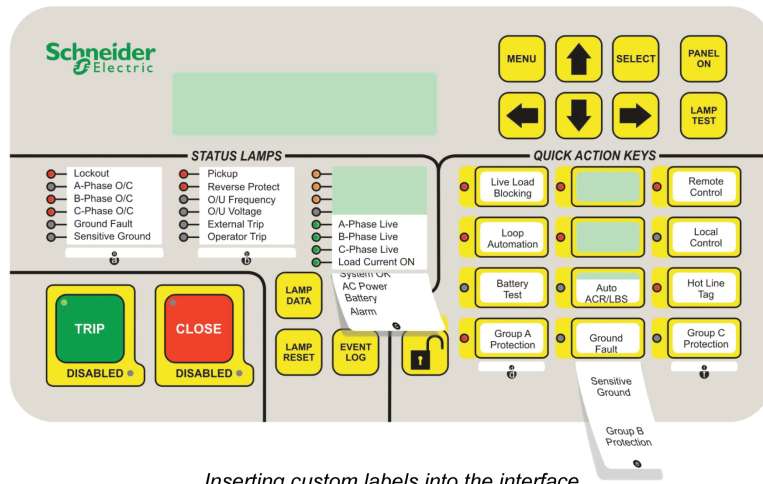

Inserting custom labels into the interface

Chapter 4

Switchgear Operating System software

WSOS

Overview

WSOS is the Schneider Electric Switchgear Operating System software. It provides easy access to the switchgear functions from opening/closing, through configuring protection and communication parameters to accessing measurement and analytical data.

By using a PC, engineers can manage many reclosers either remotely via a communications link or locally via a USB, serial port, or Ethernet connection.

Description

WSOS Version 5 integrates Schneider Electric's field proven Windows-based switchgear operating system and its powerful features and tools, developed over many years, into a modern desktop. The desktop includes the Switchgear Explorer to organise your switchgear the way you like it and the Launch Pad for handy links to online help, getting started, updates, and much more. Controlling, configuring, and accessing valuable switchgear data from a local or remote location is now even easier than before.

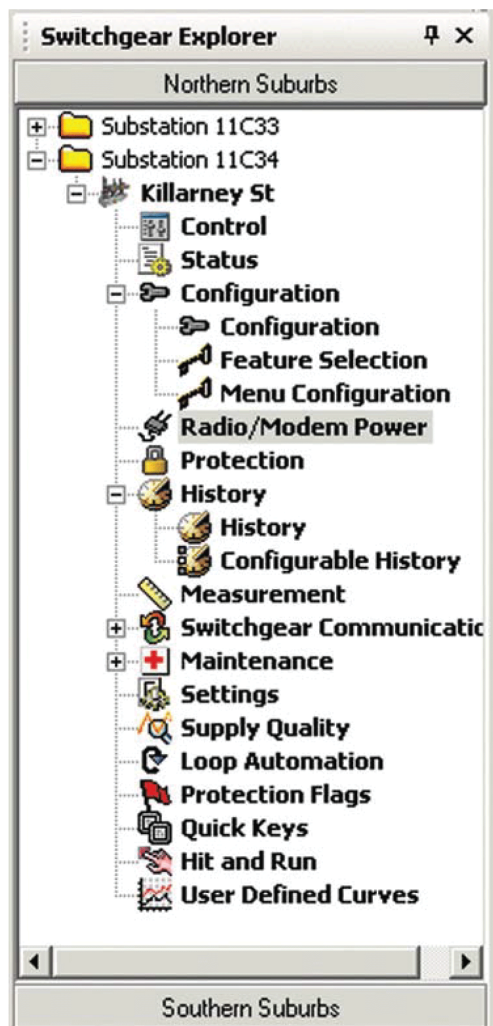

Switchgear Explorer window

Local and Remote Control

- Switchgear operation
- Protection group selection
- Protection group copy
- NPS On/Off alarm control
- Auto reclose earth protection and SEF On/Off control
- Work tag, low gas, and lockout On/Off control
- Configurable Input/Output Expander (IOEX)
- Configurable quick keys
- Configurable delay for local Open and Close operations (Hit and Run)
- Configurable SCADA protocols:
 - DNP3.0 is included as standard

Communication Options

- Local USB port
- Local RS-232 port connection
- GSM
- DNP3
- TCP/IP
- Communications output capture

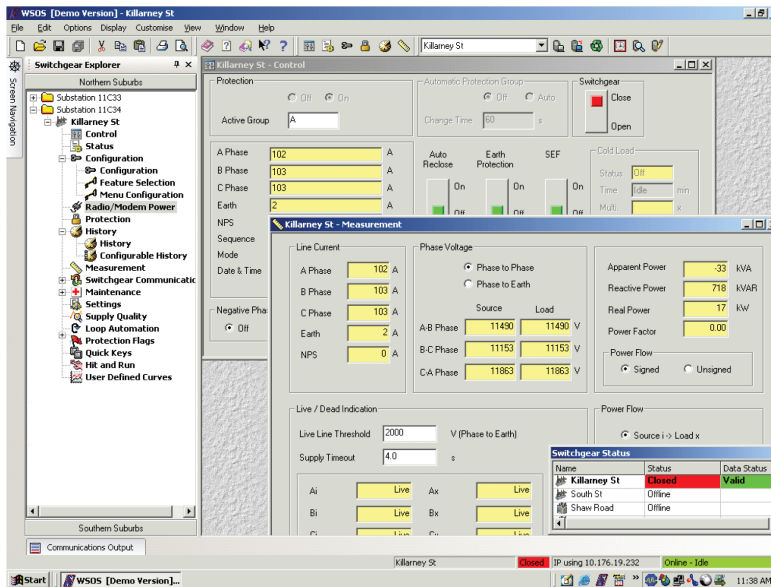

Example of the WSOS5 desktop

Measurement Screens

- Three-phase, earth, and sequence current
- Phase voltages:
 - Phase to phase
 - Phase to earth, and
 - Sequence voltages
- Sequence voltages
- Apparent, reactive, and real power
 - Total, and
 - Per phase
- Power factor
- Signed or unsigned power
- Frequency
- Power quality toolkit:
 - Waveform capture
 - Harmonics

Interface Configuration

- Status lamps:
 - Logic function to indicate; and
 - Separate true/false state color configuration
- Quick Action Keys:
 - Customize actions assigned to each key;
 - Custom logic functions for lamp indication; and
 - Separate true/false color configuration
- Print labels to insert into operator interface

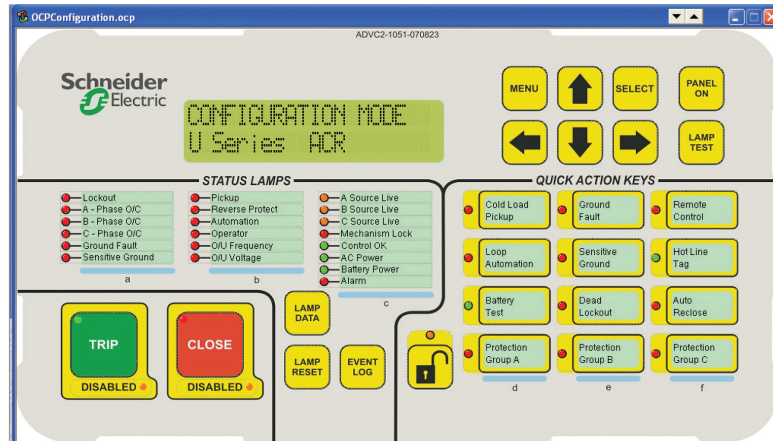

Panel Configuration Tool

NOTE: U-series shown on the screen is for representation purposes only.

Chapter 5

Other Features

What Is in This Chapter?

This chapter contains the following topics:

Topic	Page
General Protection Features	28
Advanced Protection Features	31
Measurement Features	33
Pole Mounting Details	35

General Protection Features

Operating Sequence

Reclose times are individually selectable. The operating sequence is defined by:

O - 1st rt - CO - 2nd rt - CO - 3rd rt - CO

Where rt = reclose time

Where O = open

where C = close

Reclose Times

1 st Reclose Time range	0.5–180 s
2 nd Reclose Time range	2.0–180 s
3 rd Reclose Time range	2.0–180 s
Timing resolution	0.1 s

Sequence Reset Time

Sequence Reset Time	3–180 s
Timing resolution	1 s

Trips to Lockout

Overcurrent and detected error trips to lockout are selectable from 1–4. A separate setting is available for Sensitive Earth Fault and Negative Phase Sequence.

Inverse time Curves

Three IEC60255 curves	Inverse Very Inverse and Extremely Inverse
Three IEEE C37.112 Inverse Time curves	Moderately Inverse Very Inverse and Extremely Inverse
4 2 Non-Standard Inverse Time Curves	Refer to the Operating Manual for a full listing.

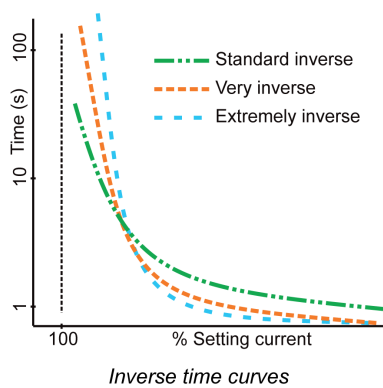

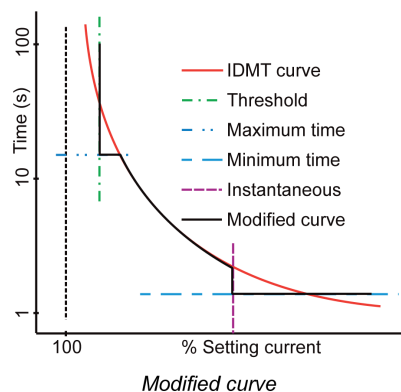

Instantaneous Protection

Instantaneous protection works by tripping the recloser if the line current exceeds the Instantaneous Multiplier x Setting Current.

Multiplier range	1–30
Resolution of setting	0.1
Max. effective setting	12.5 kV

Definite Time Protection

Definite Time is an alternative to Inverse Time protection. It works by tripping the recloser at a fixed time after pick-up.

Setting current range	10–1260 A
Definite time resolution	0.1 s
Definite time range	0.01–100 s
Setting current resolution	1 A

Sensitive Earth Fault (SEF)

SEF causes the recloser to trip when the earth current rises above a set level for longer than the set time.

SEF trip current range	1–80 A
SEF operating time range	0.1–999 s
SEF trip current setting resolution	1 A
SEF operating time resolution	0.1 s

Inrush Restraint

Inrush restraint raises the phase and earth threshold currents for a short period to allow for short duration inrush currents when closing onto a load.

Multiplier range	1–30
Multiplier resolution	0.1
Time range	0.05–30 s
Time resolution	0.05 s

Cold Load Pick-up

Cold load pick-up allows for a loss of diversity when a load has been without supply for a period of time.

Multiplier range	1–5
Multiplier resolution	0.1
Time Constant range	1–480 min
Time Constant resolution	1 min

Multiple Protection Groups

The ADVC supports up to 10 Protection Groups, each of which can be configured with separate protection characteristics with different inverse time curves and setting currents. The number of protection groups available to the operator can be configured using WSOS, thereby restricting or enabling access to protection settings as required.

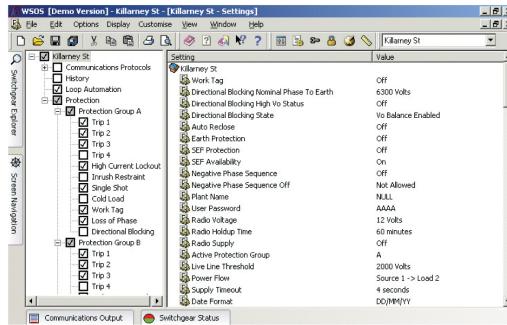

WSOS offers a quick, easy way to configure the protection groups.

Automatic Protection Group Selection

Automatic Protection Group Selection is used to modify the protection group depending on the direction of power flow. This allows the recloser to be correctly graded with devices downstream regardless of the power flow direction.

Loss of Phase

Loss of phase protection trips the recloser if phase-ground voltage on one or two phases falls below a set voltage threshold for a set length of time.

Threshold voltage range	2–15 kV
Voltage resolution	1 V
Time range	0.1–100 s
Time resolution	0.1 s

Live Load Blocking

Live load blocking avoids a recloser from closing if any of the load side terminals are live.

The Live Load threshold voltage range is 2–15 kV.

Lockout

Lockout avoids a reclose unless one or more of the source side or load side terminals are live. If all terminals are not working, then the controller goes to lockout.

Advanced Protection Features

Directional Blocking

Directional blocking is a protection feature that restricts tripping on event to a designated side of the recloser. It avoids nuisance tripping if particular network conditions are causing “false” ground event. In radial systems, Directional Blocking avoids nuisance tripping by blocking event in the source direction and only responding to event in the load direction.

Directional Protection

Distinct protection for event in the forward and reverse direction. A forward event may use a different time-current curve and settings to a reverse event (that is, these are individually selectable). Both the forward protection and reverse protection are operating at the same time. This is an additional protection feature.

Sequence Components

Negative, positive and zero-phase sequence currents and voltages can be monitored and logged.

In addition, the negative phase sequence current protection can be used for detection of low-level phase-to-phase event in the presence of high-level three-phase loads. Inverse Time, Definite Time, and Instantaneous operation is available.

The setting current range is 10–1260 A.

Sequence Coordination

Sequence coordination allows a recloser to coordinate its trip sequence with another recloser downstream.

Under/Over Frequency Protection

This feature trips the recloser when the system frequency exceeds the under and over frequency trip threshold values. Frequency tripping range: 45–65 Hz.

Frequency calculation	Once / cycle over a two cycle period
Number of under/over frequency cycles before tripping	2–1000
Accuracy	±0.05 Hz

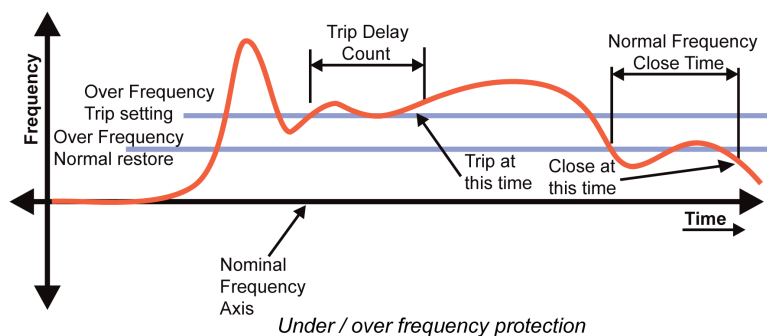

Under / Over Voltage Protection

When selected, and a nominal Phase to Ground System operating voltage is set, the UOV Protection works within a defined threshold above and below the specified voltage.

Under Voltage Lower Threshold Range	50–80%
Over Voltage Upper Threshold Range	112–150%
Trip After X secs Range	0–60 s
Phase Logic	<ul style="list-style-type: none"> ● AND: When ALL phases deviate beyond thresholds ● OR: When ANY phase voltage deviates beyond the thresholds ● AVERAGE: When the numerical AVERAGE of all phase Voltages deviates beyond the threshold.

Measurement Features

Voltage and Current

True RMS voltage is measured on the three I-Side terminals. A user configured threshold indicates live terminal. RMS current is measured on three phases (reading 2–630 A).

Real Power (Signed or Unsigned)

Real power is determined by multiplying the line voltage and line current in real time and averaging over 2 seconds (accuracy $\pm 5\%$ of reading, within limits of V and I above).

Power and Power Factor

The ADVC Controller measures kW, kVA, kVAR, and power factor on a per-phase basis.

The power factor of the line is determined from the line voltage and the line current phase relationship and the previously calculated real power (accuracy $\pm 5\%$ of reading, within limits of V and I above).

Default Historical Measurements

Power flow is integrated over 5, 15, 30, or 60 minute intervals (kWh) and recorded for a period of two months from the date of the event. This can be viewed on the operator control panel, computer, or compatible SCADA system. Additionally, data can be uploaded into a portable computer or a compatible SCADA system.

Configurable Historical Measurements

Average demand profiles may be configured using WSOS. Customised configuration enables the user to specify only the parameters that are required, negating unnecessary information capture. Parameters such as line voltages and currents, power, kWh, battery voltage, THDi, THDv, and cubicle temperature can be recorded in intervals selectable 1–1,440 min.

Event History

Maximum number of typical events stored in the event history is 100,000 events.

Power Quality Toolkit

- **Supply Outage Measurement**
 - The Supply Outage Measurement feature utilises built-in recloser features to record the number and duration of outages. These statistics are recorded in the controller and are available to the Utility to help calculate system outage customer minutes.
 - The controller records the cumulative total number of outages, cumulative total outage duration, and the time and duration of each outage event in the Event Log.
 - These records are accessible to the user and can be retrieved using the operator control panel, WSOS, or a SCADA System.
- **Harmonic Analysis**
 - Harmonics 2 to 16 and the Total Harmonic Distortion (THD) are calculated over a 80 ms period for four currents, six line-line voltages, and six line-earth voltages. These harmonics are available via WSOS
- **Waveform Capture**
 - Based on a user defined trigger, the ADVC captures and stores in non-volatile memory scaled raw data (10 x 3200 samples per second) of the six line-earth voltages and four currents for a predefined time window either side of a user-defined trigger.
 - The user can configure a pre and post trigger time ratio for data to be stored. This event to 50% pre-trigger and 50% post-trigger.
 - The captured data can be uploaded at anytime in COMTRADE (IEEE Std C37.111-1999) format via WSOS.

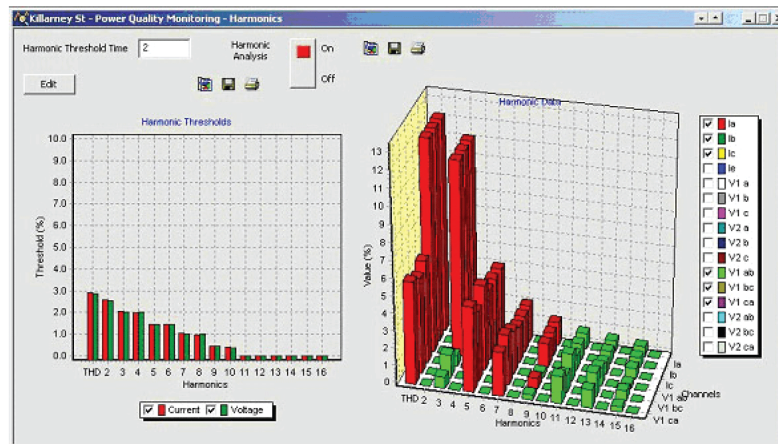

Harmonic analysis

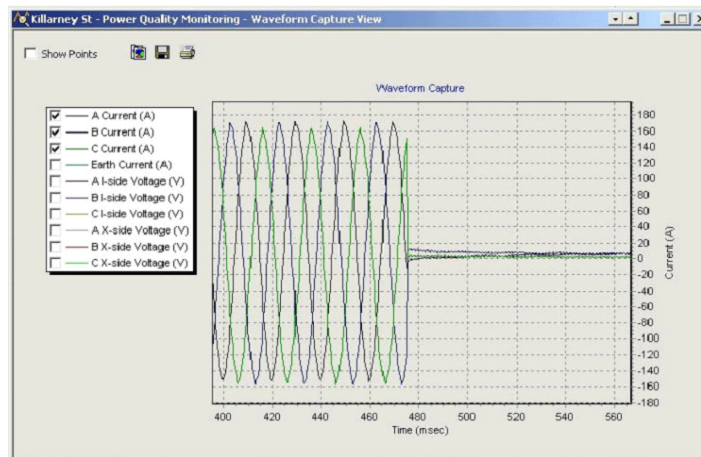

Waveform capture

Pole Mounting Details

E-Series Recloser

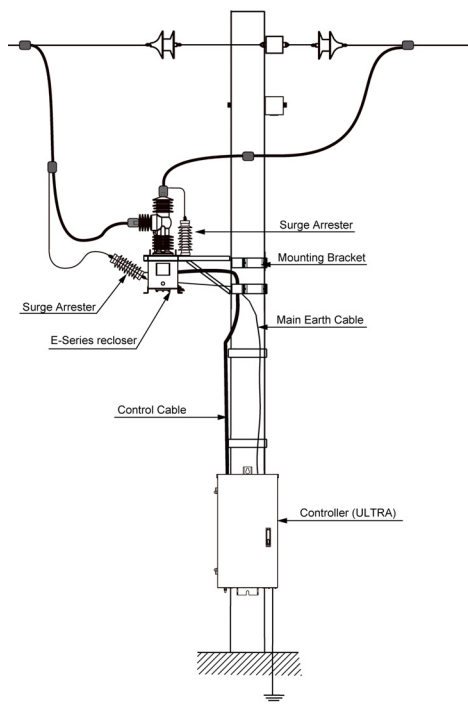

27 kV Center Mounting Example

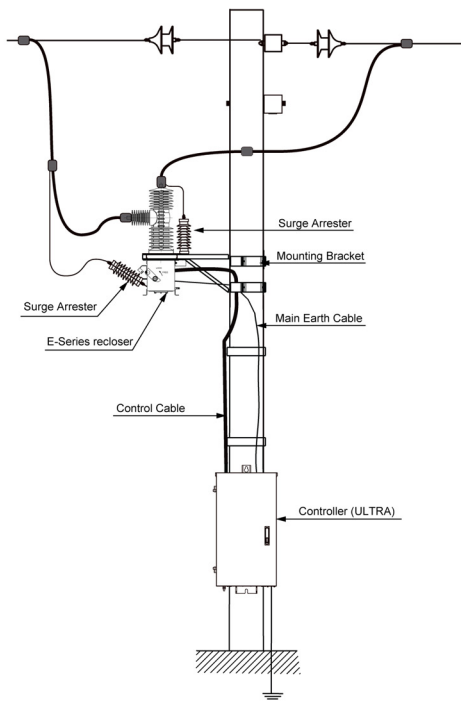

38 kV Center Mounting Example

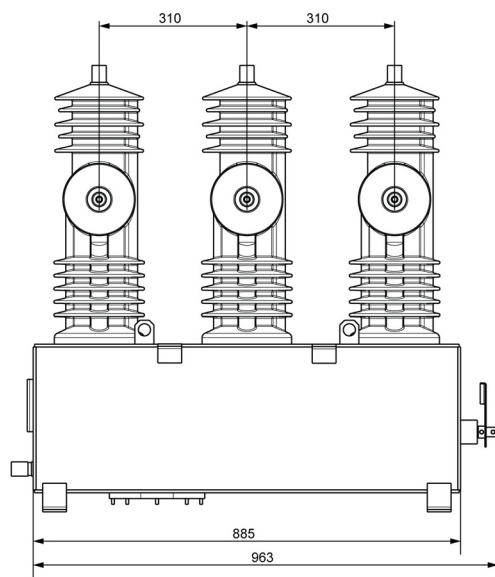

Front view of E-series 27 kV

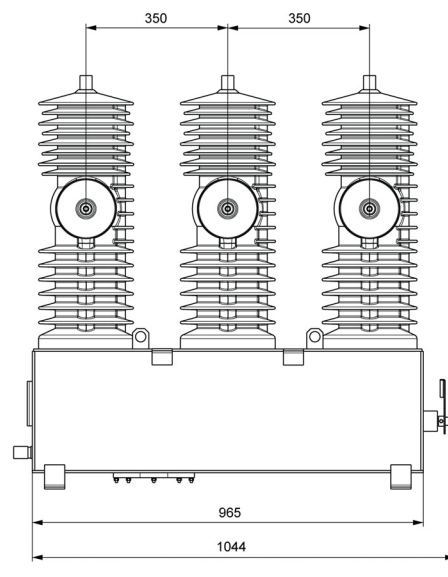

Front view of E-series 38 kV

Accessory Options

Below are the various accessory options available:

● **Connectors:**

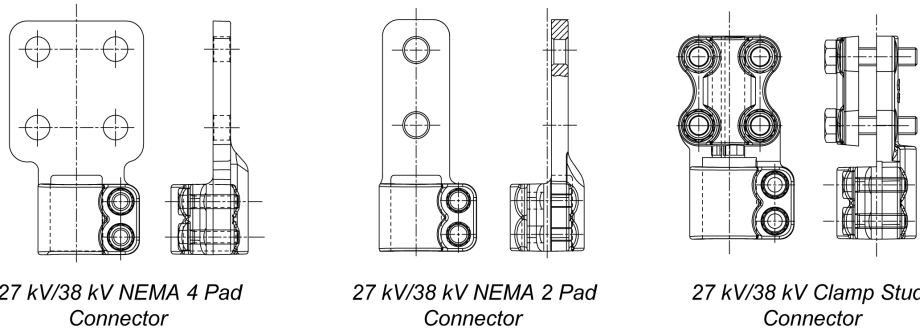

Either one of the above three connectors are required in 6 quantity or recloser.

● **Bird Guards:**

The two types of bird guards are suitable for the three types of connectors. Three quantity of source side and three quantity of load side are required for recloser.

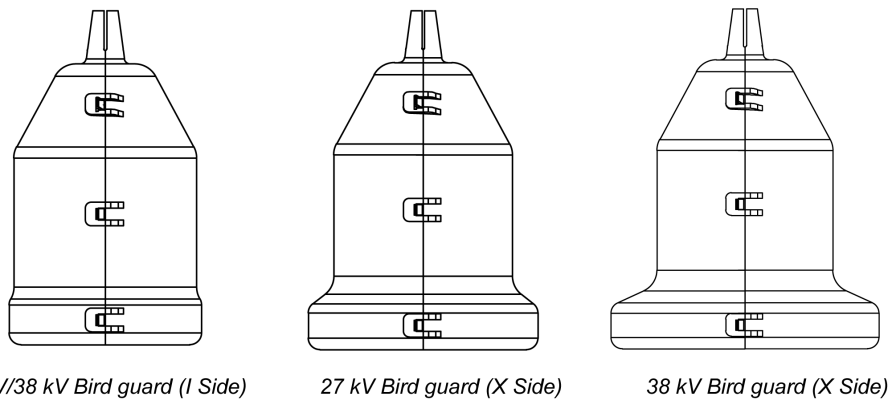

● **Mounting Brackets:**

There are two types of mounting brackets that can be used. Either one of these which are required in one quantity or recloser.

- 27 kV/38 kV mounting bracket assembly
- 27 kV/38 kV mounting bracket for wooden pole (through holes mounting)

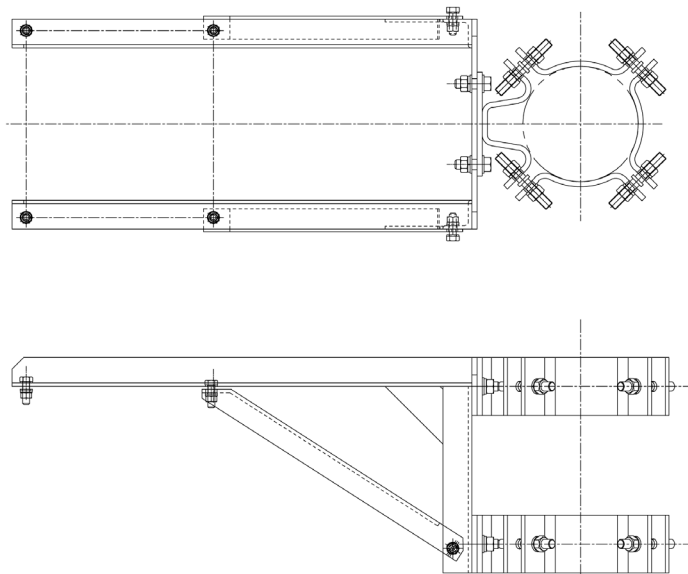

27 kV/38 kV Mounting bracket assembly
(Same mounting bracket for end and center mounting)

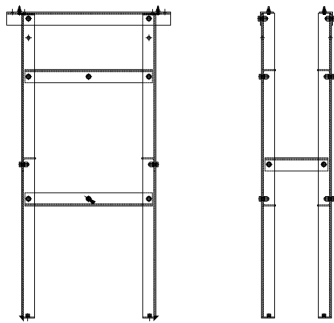
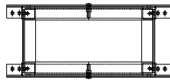

27 kV / 38 kV Substation mounting bracket

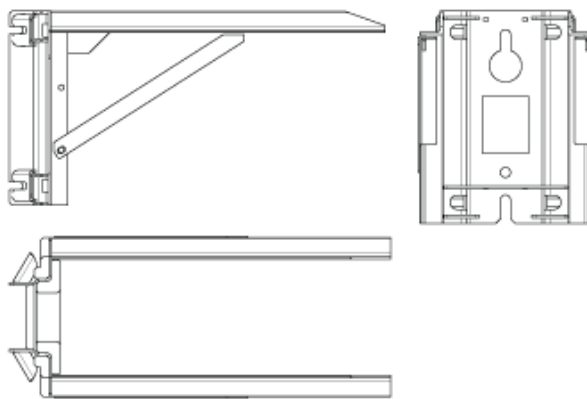

27 kV/38 kV mounting bracket for wooden pole (through holes mounting)
(Same mounting bracket for end and center mounting)

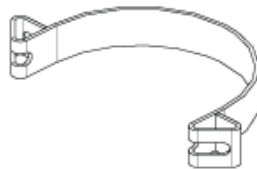

27 kV/38 kV Pole Clamp Band (if required)

● **Surge Arresters:**

Two surge arrester mounting brackets (load and source) are required in one quantity or recloser for mounting six surge arresters.

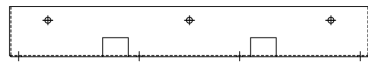

27 kV Surge arrester mounting bracket load



38 kV Surge arrester mounting bracket load

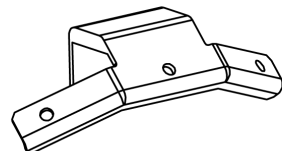
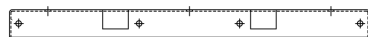

27 kV/38 kV Surge arrester mounting bracket Source

● Control Cable:

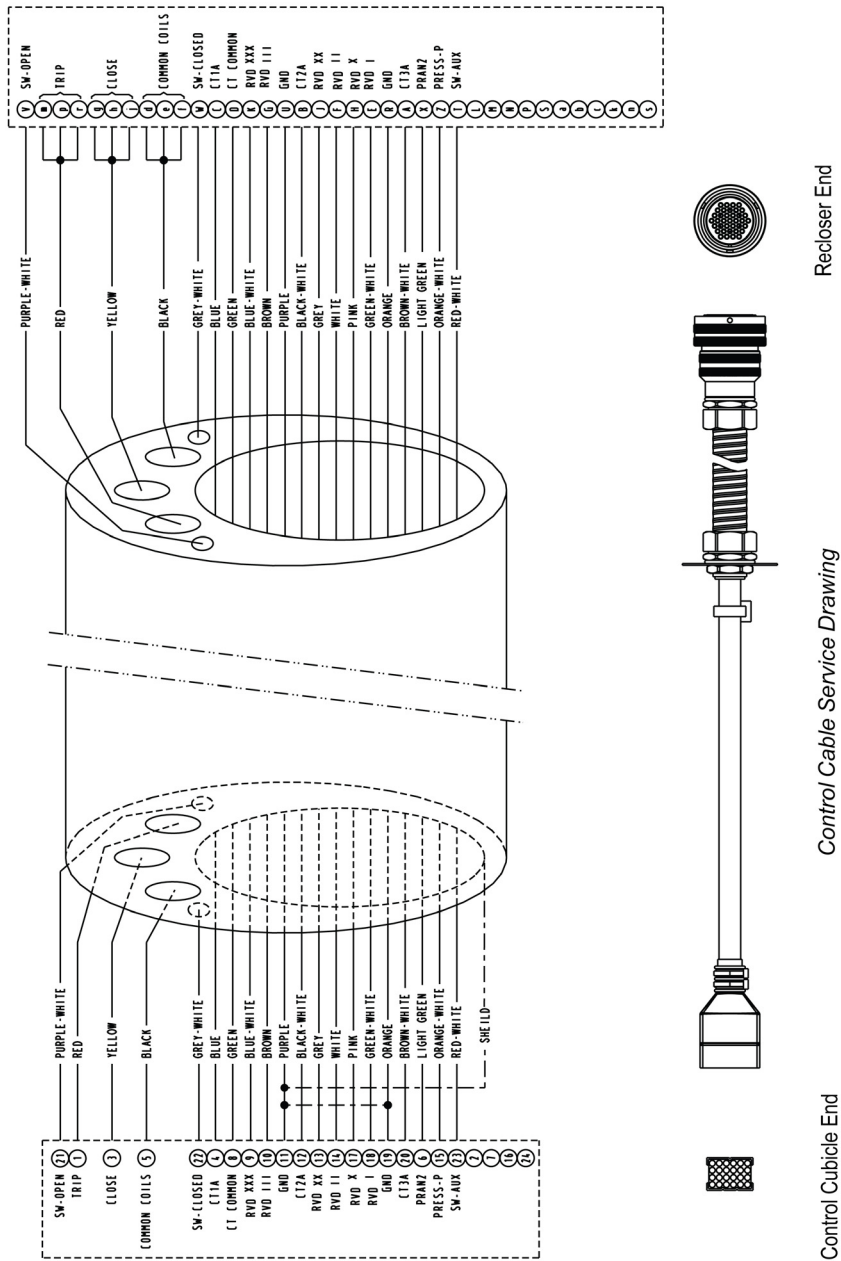

NOTE: For detailed drawings of accessories, contact Schneider Electric.

Appendices



Appendix A

Required details for order









What Is in This Chapter?

This chapter contains the following topics:

Topic	Page
ADVC Controller	42
Required Details for Order	43

ADVC Controller

Only one of the boxes (ticked or filled) with the required value) have to be considered between each horizontal line.
 Red Circle lead-time should be requested from your distributor.

ADVC Controller		Quantity <input type="text"/>	
Model <small>(Features Highlighted are only available on ULTRA)</small>	COMPACT <input type="checkbox"/>	ULTRA <input type="checkbox"/>	
Operator Interface (O.I.)	seVUE  <input type="checkbox"/>	flexVUE  <input type="checkbox"/>	
Ambient Temperature (°C)	Standard	-10°C to 50°C <input type="checkbox"/>	
	Extended With Battery Heater	-40°C to 50°C <input type="checkbox"/>	
Auxilliary Supply Type	Single AC Supply:	115 Vac <input type="checkbox"/>	230 Vac <input type="checkbox"/>
		Dual AC <input type="checkbox"/>	DC Supply <input checked="" type="checkbox"/>
		28 Hours <input type="checkbox"/>	48 Hours <input type="checkbox"/>
Maximum Battery Hold Up Time			
Language	English <input type="checkbox"/>	US English <input type="checkbox"/>	Spanish <input checked="" type="checkbox"/>
			Portugese <input checked="" type="checkbox"/>
Standard Protocol	MODBUS <input type="checkbox"/>	IEC <input type="checkbox"/>	DNP3 <input type="checkbox"/>
Accessories <small>(Additional Costs May Apply)</small>			
FTIM <small>(Ultra FTIM cable only)</small>	Not Applicable <input type="checkbox"/>	Yes <input checked="" type="checkbox"/>	
IOEX	Not Applicable <input type="checkbox"/>	Yes <input checked="" type="checkbox"/>	
General Purpose IEC Socket	Not Applicable <input type="checkbox"/>		Yes <input type="checkbox"/>
GPO 10A max.	None <input type="checkbox"/>		
<small>Only with IEC Socket</small>	AUS  <input type="checkbox"/>	EU-A  <input checked="" type="checkbox"/>	EU-B  <input checked="" type="checkbox"/>
	Other <input type="checkbox"/>	UK  <input checked="" type="checkbox"/>	USA  <input checked="" type="checkbox"/>
		Sth Afric  <input checked="" type="checkbox"/>	

Special notes <small>(For other available Accessories, contact local suppliers)</small>

Required Details for Order

E-Series Recloser (E15, E27, and E38)

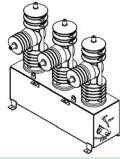

Only one of the boxes (ticked or filled with the required value) have to be considered between each horizontal line. Red Circle lead-time should be requested from your distributor.

Certain configurations may attract additional cost. To clarify these details, please consult your local distributor.

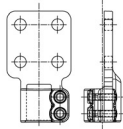
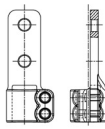
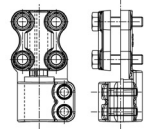
Circuit Breaker Unit		Quantity <input type="text"/>
Rating (System Voltage / Interrupt / BIL)	15.5 kV/12.5 kA/110 kV <input type="checkbox"/> 27 kV/12.5 kA/150 kV <input type="checkbox"/> 38 kV/16 kA/170 kV <input type="checkbox"/>	
Rated Current (A)	630 A/800 A* (for 27 kV) <input type="checkbox"/> 800 A/1250 A* (for 38 kV) <input type="checkbox"/>	
Frequency	50 Hz Standard <input type="checkbox"/> 60 Hz Standard <input type="checkbox"/>	
Sensitive Earth Fault Rating	1 - 20 A <input type="checkbox"/>	
Language	English <input type="checkbox"/>	
Accessories		
Mounting Arrangement	Front/End mount <input type="checkbox"/> Substation mount <input type="checkbox"/> Front/End: Through holes for wooden poles <input type="checkbox"/>	
Control Cable Length	7 Metres (Default) <input type="checkbox"/> 11 Metres <input type="checkbox"/> 20 Metres <input type="checkbox"/>	
Birdguards	Source and Load side: Yes <input type="checkbox"/> No <input type="checkbox"/>	
Options		
Medium Voltage Terminal Options (Set of 6)	27/38 kV NEMA 4 Pad Connector <input type="checkbox"/> 27/38 kV NEMA 2 Pad Connector <input type="checkbox"/> 27/38kV Clamp Stud Connector <input type="checkbox"/>	
	  	
Surge Arrester Brackets	Standard Inclusion <input type="checkbox"/>	
<i>Set of 2 brackets with End Mount and Center Mount option.</i>		
Surge Arresters	Not Applicable <input type="checkbox"/> Surge Arresters <input checked="" type="checkbox"/>	
VT Mounting	Not Applicable <input type="checkbox"/> Pole Mounted <input type="checkbox"/>	

* For more details, consult Schneider Electric



N00-803-03

Schneider Electric Industries SAS

35, rue Joseph Monier
CS30323
F - 92506 Rueil Malmaison Cedex

www.schneider-electric.com

As standards, specifications and designs change from time to time, please ask for confirmation of the information given in this publication.

01/2019