

SIEMENS



Digital Grid Products

SICAM Fault Sensor Indicator (FSI)

The Guardian for your Overhead Line Networks

SICAM Fault Sensor Indicator (FSI)



Description

SICAM Fault Sensor Indicator (FSI) **6MD2314** measures the phase current continuously and detects the phase fault and ground fault when it is mounted on the MV overhead line network. The device indicates both the temporary fault and permanent fault via an optical indication.

SICAM FSI (6MD2314) device is developed using the latest generation of hardware technology and is a member of the Siemens SICAM® short-circuit indicator product family.

SICAM FSI is used to improve the distribution grid reliability and reduce the power outages on the MV overhead line.

SICAM FSI can be mounted (in groups of 3 or 6 or 9) on each phase after the branching points and sectionalizer.

The device is available in 2 variants:

- **SICAM FSI (6MD2314 - 1AB10)**
The faults are indicated by LEDs. Depending on the fault type, a specific flashing sequence is generated.
- **SICAM FSI with integrated communication (6MD2314 - 1AB11)**
In addition to local LED display, the phase fault and ground fault events are communicated to the SICAM Fault Collector Gateway (FCG) via a secured short-range radio (wireless) communication.

The SICAM FCG transmits fault information to the control center based on the telecontrol protocols IEC 60870-5-104 or DNP3 via GSM/GPRS networks.

Features

The salient features of SICAM FSI are:

- **Supports installation** on non-insulated and insulated cables.
- **Higher availability of overhead line networks** - Quick fault detection and localization, reduced downtime.
- **Self sustained** - Equipped to harvest power from the MV overhead line which helps to extend the battery life beyond 10 years for SICAM FSI, under standard operating conditions. The device life is further enhanced by 5 years if the energy harvesting is operational.
- **Secure** - Protection against unauthorized access. Authentication and encryption via AES 128, shared keys.
- **Maintenance free** - Robust design with IP65 and UV resistant housing.
- **Simple configuration** - Easy device configuration with QR code on SICAM FSI and via SICAM FCG Web GUI.

System Diagram of FSI and FCG

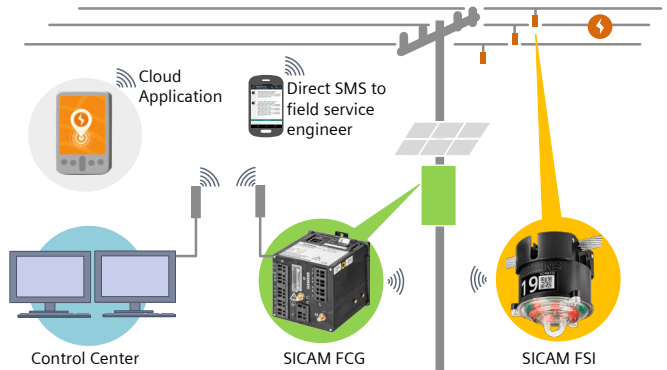

SICAM FSI is configurable in coordination with upstream protection system (settings like permanent-fault verification time and automatic reclosing time).

The SICAM FSI with integrated communication uses the short-range radio (wireless) for transmitting the fault information instantaneously to the control center via SICAM FCG. The fault indication can also be reset remotely from the control center. The fault parameters and other settings are remotely configurable.

Applications

SICAM FSI operates on the MV overhead distribution line.

Operating range	3.3 kV to 66 kV (Non-insulated cable)
	6.6 kV to 66 kV (Insulated cable)
System frequency	50 Hz or 60 Hz network
Grounding type	Solidly grounded system or resistive star-point grounded systems
Conductor overall diameter	5 mm to 40 mm (Non-insulated)
	15 mm to 40 mm (Insulated)*
Non-insulated conductor type	Aluminium Conductor Steel Reinforced (ACSR)
Insulated conductor type	Single core, aluminium conductor steel reinforced with/without water-blocking, XLPE insulated
* SICAM FSI with conductor overall diameter 5mm to 15mm (Insulated) can be ordered only on a special request. Contact the local Siemens office for more information.	

SICAM FSI Configuration

SICAM FSI

Before installing the SICAM FSI on the MV overhead line, configure the basic parameters and advance device parameters by using the SICAM FSI configurator.

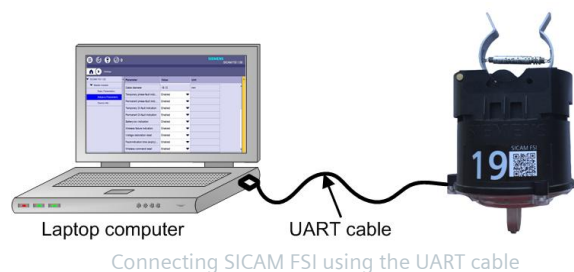

SICAM FSI with integrated communication

Before commissioning the SICAM FSI and SICAM FCG, configure the SICAM FSI QR code in the SICAM FCG configuration page. After the configuration, the secured communication channel between SICAM FSI and SICAM FCG is established.

For more information about SICAM FCG and SICAM FSI commissioning, refer to the **SICAM Fault Sensor Indicator Manual**.

Technical Data

For full technical data, refer to the technical specification section of the user manual.

Application Data

Rated voltage (V_{rated})	3.3 kV to 66 kV (Non-insulated cable)
	6.6 kV to 66 kV (Insulated cable)
System frequency	50 Hz/60 Hz
Conductor overall diameter	5 mm to 40mm (Non-insulated), 15 mm to 40 mm (Insulated)
Measurement cycle period	20 ms (For 50 Hz)
	16.6 ms (For 60 Hz)
Voltage presence	> 70 % of V_{rated}
Voltage absence	< 45 % of V_{rated}
Rated current (I_{rated})	50 A up to 500 A (steps of 50 A)
Current measurement accuracy	± 10 % from 50 A to 800 A (50 Hz and 60 Hz)
Power source	Lithium -thionyl chloride battery+ energy harvesting*
Total Fault indication time	400 hours of LED flashing

* Energy harvesting starts if the phase current exceeds 60 A.

Fault Detection Parameters

di current	5 A to 80 A (steps of 5 A), 120 A, 160 A
Current threshold	1.5 I_{rated} to 3 I_{rated} (steps of 0.5)
Fault-indication time	2 h to 16 h (steps of 0.5 h)
Inrush restraint time	3 s, 30 s, and 60 s
Permanent-fault verification time	3 s, 35 s, and 70 s
Automatic reclosing time	0.1 s to 99.9 s

Communication

Communication mode	Short-range radio (wireless), Frequency band 2440 MHz (IEEE 802.15.4)
--------------------	---

NOTE:

The communication mode is applicable for the SICAM FSI with integrated communication (6MD2314-1AB11).

RF Output Power

RF output power range used by SICAM FSI for country/region	10 dBm to 20 dBm
--	------------------

Fault Reset (Permanent Faults)

Voltage restoration reset	$V_{rated} > 70$ %
Magnet reset	Using magnetic adaptor
Remote reset	Via SICAM FCG from the control center (SICAM FSI with integrated communication)
Auto timer reset	2 h to 16 h (steps of 0.5 h)

Fault Indication

Indication	6 high luminous red LEDs
Luminous flux	40 lumens
Visibility angle	360 ° (from ground level)
Visibility range	50 m day time, 300 m night time

Mechanical

Weight	0.78 kg
Dimensions	116 mm dia x 210 mm height



Indication of Conformity

This product complies with the directive of the Council of the European Communities on the harmonization of the laws of the Member States relating to electromagnetic compatibility (EMC Directive 2014/30/EU) and concerning electrical equipment for use within specified voltage limits (Low Voltage Directive 2014/35/EU) as well as restriction on usage of hazardous substances in electrical and electronic equipment (RoHS Directive 2011/65/EU).

This conformity has been proved by tests conducted by Siemens AG in accordance of the Council Directive in accordance with the product standard IEC/EN 61326-1 for the EMC directives, and with the standard IEC/EN 61010-1 for the low-voltage directive.

Harmonised standards for short-range radio communication acc. to RED directive 2014/53/EU:

- EMC testing acc. to EN 301 489
- Short-range radio acc. to EN 300 328

RoHS directive 2011/65/EU is met using the standard EN 50581. The device has been designed and produced for industrial use.

Type Testing

This section describes about the type testing performed on SICAM FSI.

Electrical Tests

Test	Standards	Tests Requirements
Dielectric strength withstand	IEC/EN 61010-1	125 kV AC [#]
Short-circuit current withstand-ing test	IEEE 495	12.5 kA @ 1 s 25 kA @ 170 ms

[#] Dielectric strength of 125 kV AC is achieved by using Siemens recommended hot stick for mounting the SICAM FSI up to 66 kV overhead line.

EMC Tests for Immunity

Test	Standards	Tests Requirements
Electrostatic discharge, Level 3	EN 301 489-1, EN 301 489-3, IEC 61000-4-2	8 kV air discharge and 6 kV contact discharge
Radiated Radio frequency electromagnetic field	EN 301 489-1, EN 301 489-3, IEC 61000-4-3	80 MHz to 1000 GHz (10 V/m, Level 3) 1 GHz to 6 GHz (3 V/m, Level 2)
Power frequency magnetic field, Level 4	IEC 61000-4-8	30 A/m (continuous) and 300 A/m (short time) on the X, Y, and Z axis of the product

EMC Tests for Noise Emission

Test	Standards	Tests Requirements
Radiated emission test, Class A	EN 301 489-1, EN 301 489-3, EN 55032	30 MHz to 6 GHz (class A)

Safety Testing

Test	Standards
Safety test	IEC/EN 61010-1
Test Description	Applicable Clause No.
Marking and Documentation	5
Protection against mechanical hazard	7
Resistance to mechanical stresses (shock and impact)	8
Protection against the spread of fire	9
Protection against liberated gases and substances, explosion and implosion	13
Components and sub assemblies	14
HAZARDS resulting from application	16
Risk Assessment	17

Environmental Tests

Test	Standards	Tests Requirements
Dry cold test	IEC 60068-2-1	-25 ° C
Dry heat test	IEC 60068-2-2	+70 ° C
Damp heat steady	IEC 60068-2-78	40 ° C; 95 % RH
Damp heat cyclic	IEC 60068-2-30	25 ° C to 40 ° C; 95% RH (6 cycles with 12 h + 12 h)
Storage temperature*	IEC 60068-2-48	- 25 ° C to 70 ° C
Average rainfall	-	750 mm

Exposure to direct sunlight (UV)	ASTM G155	14 days
Wind resistance	-	200 km per hour
Salt spray test	ASTM B117	72 hours
Ingress protection	IEC 60529	IP65

* For optimum battery capacity, it is recommended to store the device below 30 ° C; 40% RH.

Mechanical Tests

Test	Standards	Tests Requirements
Vibration response test, Class 1	IEC 60068-2-6	Sinusoidal Frequency: 10 Hz to 500 Hz Displacement: 0.7 mm peak to peak from 10 Hz to 59 Hz Amplitude: 5 g from 59 Hz to 500 Hz Sweep rate: 1 oct./min Number of sweeps: 01/axis Number of axes: 3 (X, Y, and Z)
Bump test	IEC60068-2-27/ IEC60068-2-29	Acceleration: 40 g Duration: 6 ms Number of sweeps: 2000 positive and 2000 negative shocks Number of axes: 3 (X, Y, and Z) Number of bumps: 1000 per direction Number of direction: 2 per axis Total number of bumps: 6000

Short-Range Radio (Wireless) Testing

Test	Standards	Tests Requirements
Spurious emission	EN 300 328	Transmitter unwanted emissions in the spurious domain and receiver spurious emissions Operating frequency range: 2400 MHz to 2480 MHz No. of channel: 16 Modulation: Other than FHSS (DSSS) Channel Spacing: 5 MHz

Certifications

Test	Standards	Tests Requirements
WPC ETA certification	-	2405 to 2480 MHz WPC ETA certification is performed as per R&TTE/RED directive

Optical Tests

Test	Standards	Tests Requirements
Lumens test	LM79	40 lumens
Goniometry test	LM79	360 ° visibility

Ordering Information - Device

Use the following MLFB series to order the SICAM FSI (SICAM FSI and SICAM FSI with integrated communication) devices:

6MD2314-1AB10	SICAM FSI <ul style="list-style-type: none"> Phase-fault detection Ground-fault (di/dt) detection UV stabilized polycarbonate IP65 rated housing Visual fault indication of 40 lumens by 6 high luminous red LEDs
6MD2314-1AB11*	SICAM FSI with integrated communication* <ul style="list-style-type: none"> Short-range radio (wireless) communication for current measurements and fault status Phase-fault detection Ground-fault (di/dt) detection UV stabilized polycarbonate IP65 rated housing Visual fault indication of 40 lumens by 6 high luminous red LEDs

* SICAM FSI with integrated communication along with SICAM FCG (**6MD2340-3JM71-8AA2**) should be ordered when the communication with control center is required.

SICAM FSI and SICAM FSI with integrated communication for Vietnam market should be ordered as **6MD2314-1AB10 -Z HW /FF** and **6MD2314-1AB11 -Z HW /FF** respectively.



Ordering Information - Spares



Use the following MLFB series to order the SICAM FSI spares:

Spares MLFB	Spares Description
6MD2318 - 4BB00	SICAM FSI Li-TH Battery Set (Pack of 6)

Ordering Information - Accessories

Use the following MLFB series or the third-party product to order the SICAM FSI accessories:

Accessories MLFB	Accessories Description
6MD2318 - 4AA00	UART cable for the device configuration (Recommended make : FTDI Chip, part number TTL-232R-RPi) For more information on FTDI UART cable, visit: http://www.ftdichip.com/ 
6MD2318 - 4MA04	Magnet adaptor for device reset, accessory for hot stick with shotgun 

<p>6MD2318 - 4MA05</p>	<p>Device adaptor for SICAM FSI mounting via hot stick (telescopic)</p> 
<p>Accessory Description</p>	
<p>Hot stick with shotgun for FSI mounting, 4 m</p>	<p>Recommended make : Ritz, Cat.No: RC403-0295 : Hubbell, Cat.No: C4030295</p> <p>For more information on Ritz Hot Stick with Shotgun, visit: http://www.terexutilities.com.br/</p> <p>For more information on Hubbell Hot Stick with Shotgun, visit: http://hubbellpowersystems.com/</p> 
<p>Hot stick (telescopic) for FSI mounting, 12 m</p>	<p>Recommended make : Ritz, Cat.No: VTT-1/9</p> <p>For more information on Ritz Hot Stick (telescopic), visit: http://www.terexutilities.com.br/</p> 

Case Dimensions

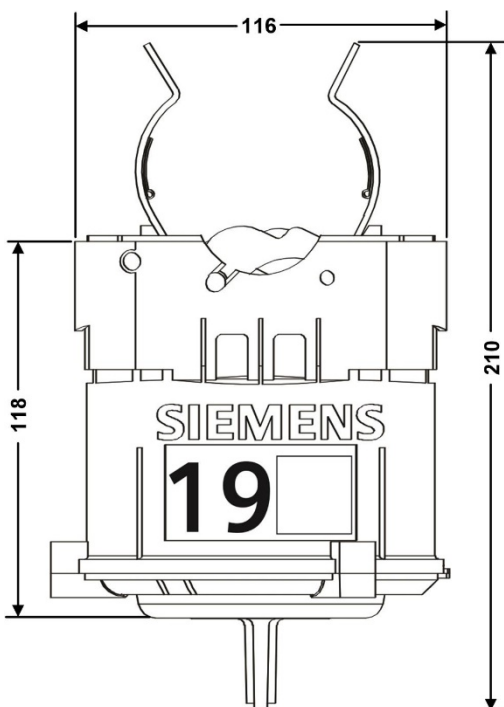

Fig 4. Front View

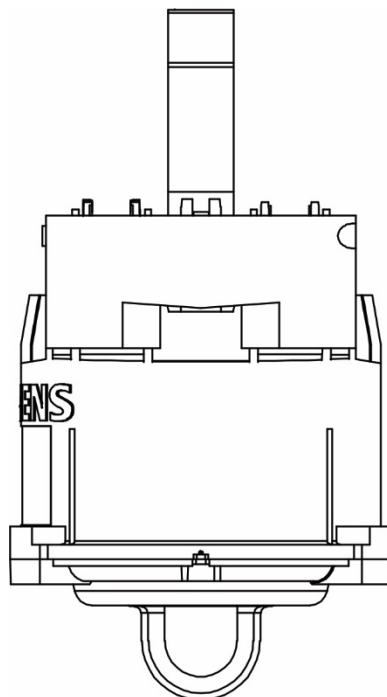

Fig 6. Side View

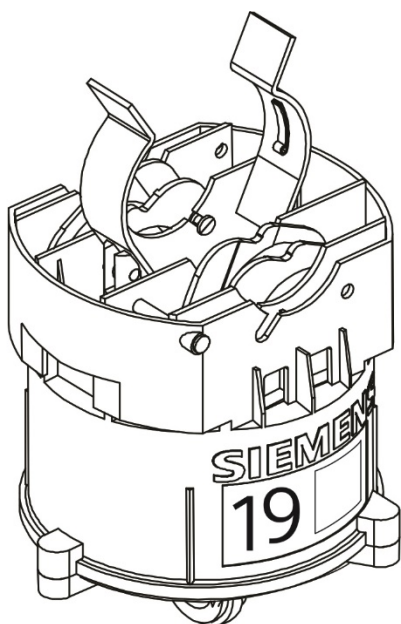

Fig 5. Isometric View

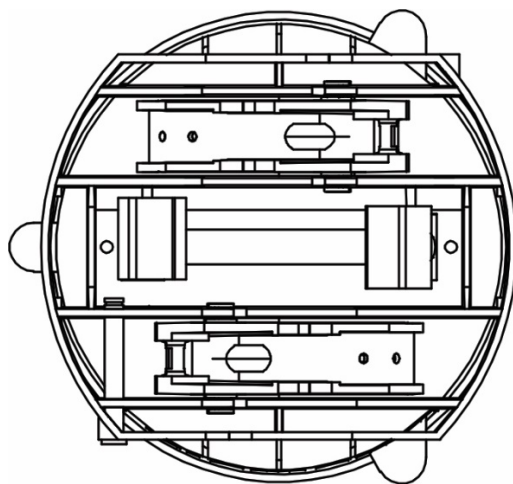

Fig 7. Top View

NOTE: All the dimensions are in mm

E50417-K1040-C587-A6

For any technical queries, please contact our customer support center

Phone: +49 (180) 524-7000

Fax: +49 (180) 524-2471

E-Mail: support.energy@siemens.com.